

- NOTE:**
1. GRILL FINISHED W/ HEAT RESISTANT BLACK ENAMEL
 2. GRILL ROTATES FREELY 360° FOR DRAFT CONTROL

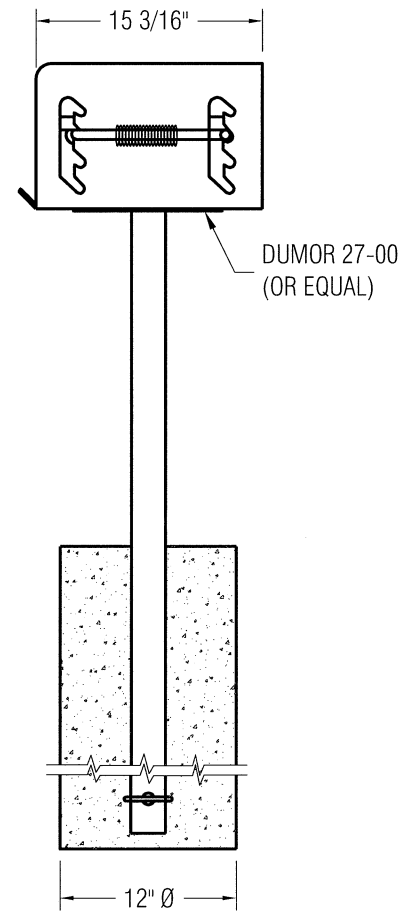
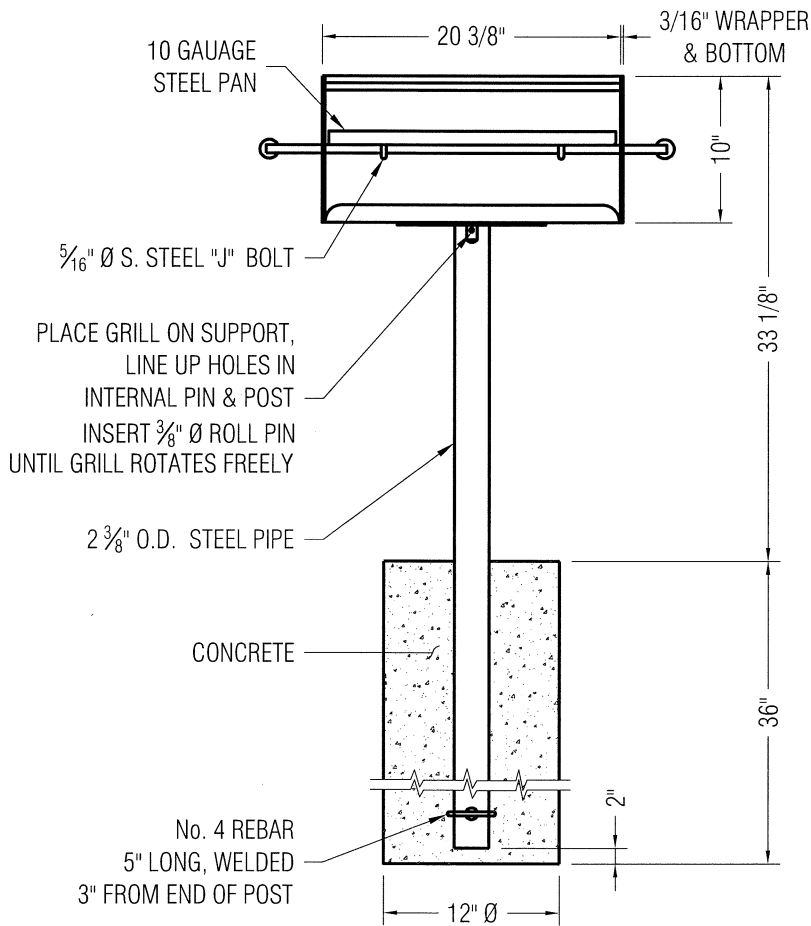

Approved: _____

City Engineer

Date

1/4/10

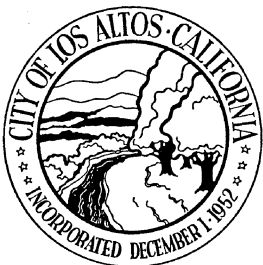

REVISION

Description	Date

ENGINEERING DIVISION

PARK GRILL

LI-8