



1 Proposed West (Rear) Elevation
1/4" = 1'-0"



2 Existing West (Rear) Elevation
1/4" = 1'-0"

Submittal:

CLIENT REVIEW	6.12.14
HISTORICAL REVIEW	7.1.14
PLANNING REVIEW	7.21.14
DESIGN REVIEW	9.12.14
CLIENT REVIEW	12.15.14

Hitz Residence
452 University Avenue
Los Altos, California

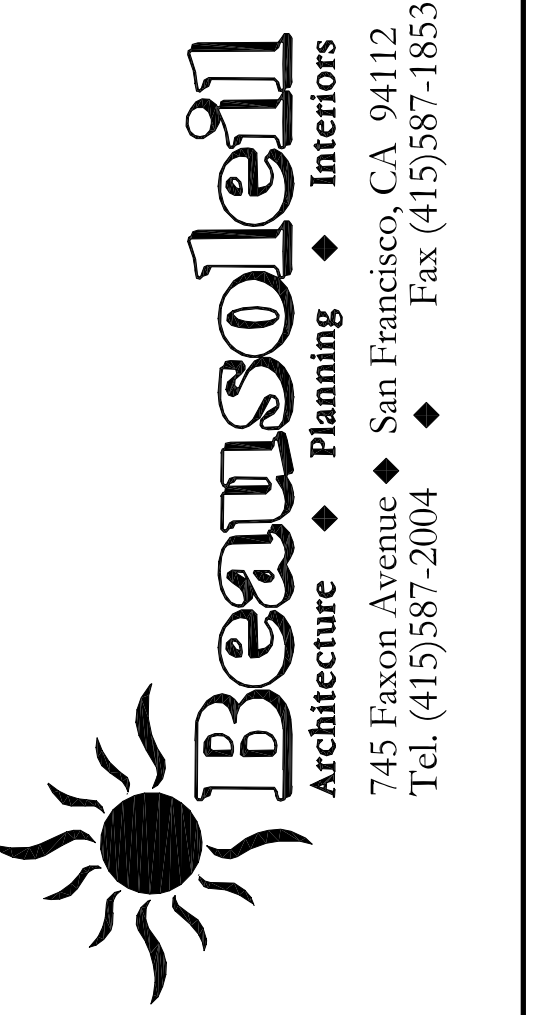

Sheet Title
ELEVATIONS

Scale	1/4" = 1'-0"
Project No.	1407
Date	6.23.14
Drawn By	RB
Sheet No.	

A3.3

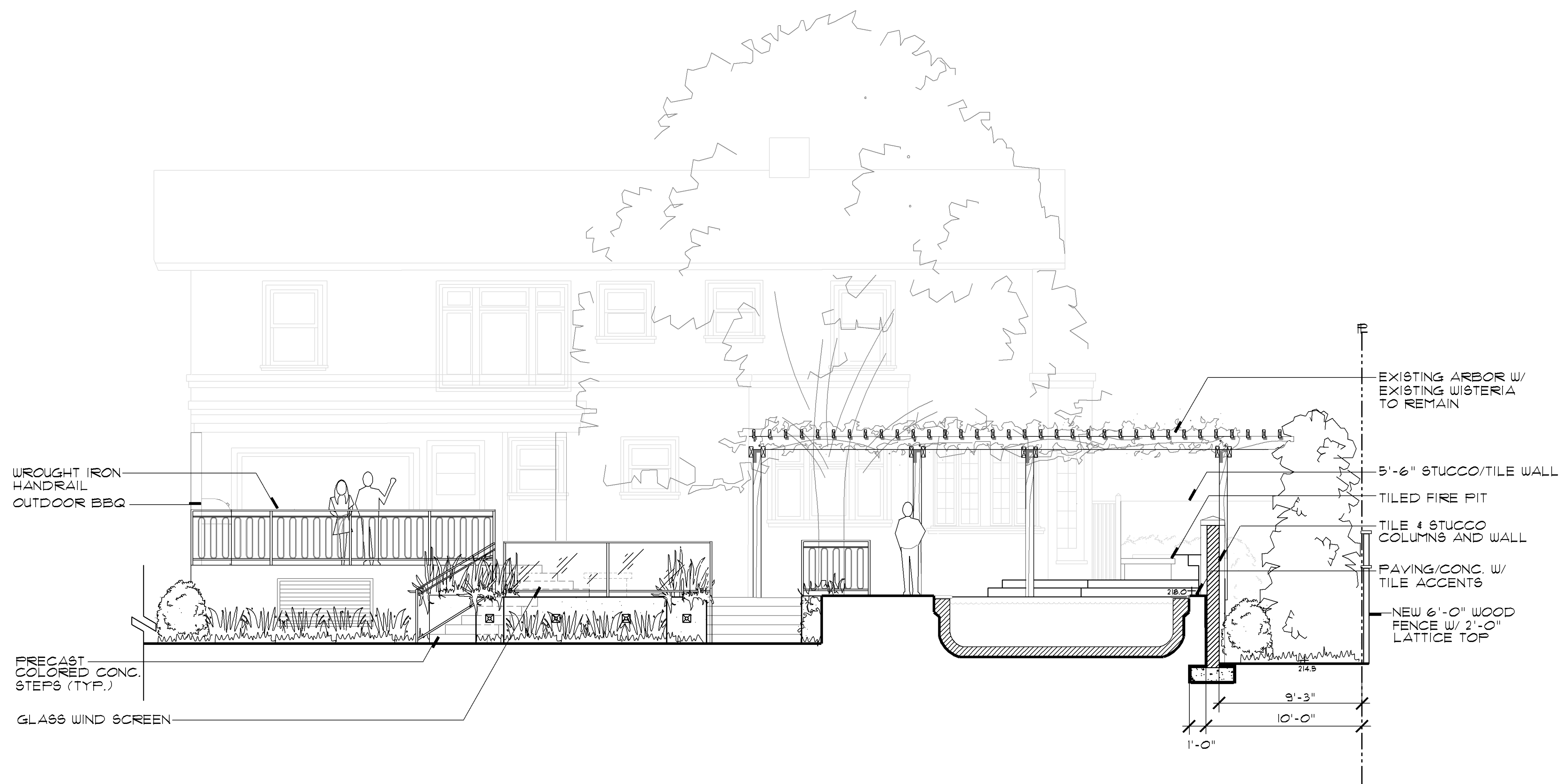

ELEVATION PLAN - A

SCALE: 1/4" = 1'-0" RMA ©2015 JAN 9, 2015

ROBERT MOWAT ASSOCIATES
LANDSCAPE ARCHITECTURE + LAND PLANNING
1501 N. Broadway Suite 400 Walnut Creek, CA 94596
Phone 925.705.7424 Fax 925.954.1390
www.rmalandscape.com

HITZ RESIDENCE
452 University Ave
Los Altos, Ca 94022

ELEVATION

DATE
REVISIONS

SCALE

SHEET

OF X

© COPYRIGHT 2015 Robert Mowat Associates. No portion of this drawing may be reproduced, duplicated, or copied in any way without the express written consent of Robert Mowat Associates. This drawing is prepared for this particular site and may not be utilized for another site location.

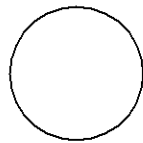
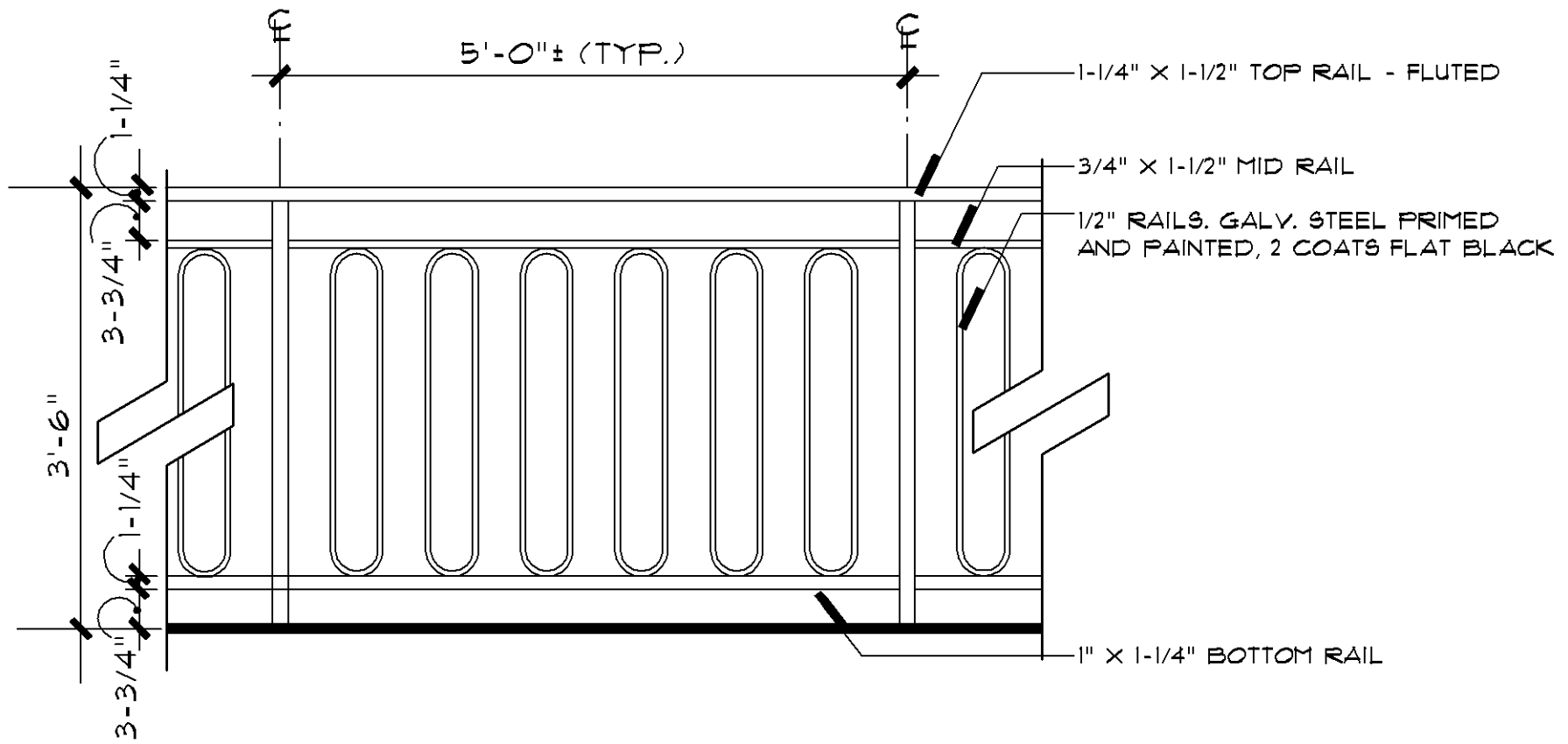

W.I. HANDRAIL

SCALE: 3/4" - 1'-0"

270.68 HANDRAIL