

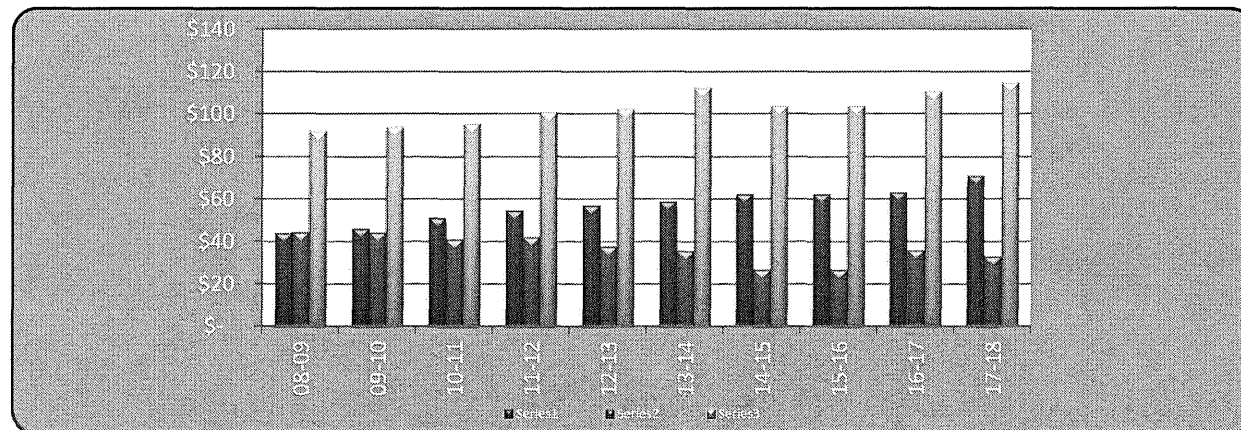

**City of Los Altos  
Net Position by Component  
Last Ten Fiscal Years**

*(accrual basis of accounting; amounts expressed in thousands)*

	2008-09	2009-10	2010-11	2011-12	2012-13(a)	2013-14	2014-15	2015-16	2016-17	2017-18
<b>Governmental activities</b>										
Net investment in capital assets	\$ 40,684	\$ 42,596	\$ 46,011	\$ 48,511	\$ 50,102	\$ 50,164	\$ 49,079	\$ 53,409	\$ 54,725	\$ 61,525
Restricted	3,477	3,411	3,057	3,926	7,406	17,629	17,815	14,447	11,498	10,620
Unrestricted	36,184	35,476	33,448	34,634	29,883	27,624	10,746	15,583	24,047	20,429
<b>Total governmental activities net position</b>	<b>\$ 80,345</b>	<b>\$ 81,483</b>	<b>\$ 82,516</b>	<b>\$ 87,071</b>	<b>\$ 87,391</b>	<b>\$ 95,417</b>	<b>\$ 77,640</b>	<b>\$ 83,439</b>	<b>\$ 90,270</b>	<b>\$ 92,574</b>
<b>Business-type activities</b>										
Net investment in capital assets	\$ 3,316	\$ 3,552	\$ 5,197	\$ 5,952	\$ 6,773	\$ 8,718	\$ 8,662	\$ 8,726	\$ 8,403	\$ 9,450
Unrestricted	8,102	8,766	7,625	7,539	7,843	8,087	8,472	11,259	11,907	12,644
<b>Total business-type activities net position</b>	<b>\$ 11,418</b>	<b>\$ 12,318</b>	<b>\$ 12,822</b>	<b>\$ 13,491</b>	<b>\$ 14,616</b>	<b>\$ 16,805</b>	<b>\$ 17,134</b>	<b>\$ 19,985</b>	<b>\$ 20,310</b>	<b>\$ 22,094</b>
<b>Primary government</b>										
Net investment in capital assets	\$ 44,000	\$ 46,148	\$ 51,208	\$ 54,463	\$ 56,875	\$ 58,882	\$ 57,741	\$ 62,135	\$ 63,128	\$ 70,975
Restricted	3,477	3,411	3,057	3,926	7,406	17,629	17,815	14,447	11,498	10,620
Unrestricted	44,286	44,242	41,073	42,173	37,726	35,711	19,218	26,842	35,954	33,073
<b>Total primary government net position</b>	<b>\$ 91,763</b>	<b>\$ 93,801</b>	<b>\$ 95,338</b>	<b>\$ 100,562</b>	<b>\$ 102,007</b>	<b>\$ 112,222</b>	<b>\$ 94,774</b>	<b>\$ 103,424</b>	<b>\$ 110,580</b>	<b>\$ 114,668</b>



Source:

City of Los Altos Finance Department

Note:

(a) The City implemented the provisions of GASB Statement 63 in fiscal year 2013, which replaced the term "Net Assets" with the term "Net Position"

City of Los Altos

Changes in Net Position

Last Ten Fiscal Years

(accrual basis of accounting; amounts expressed in thousands)

	2008-09	2009-10	2010-11	2011-12	2012-13	2013-14	2014-15	2015-16	2016-17	2017-18
<b>Expenses</b>										
Governmental activities:										
Public safety	\$ 13,563	\$ 13,812	\$ 14,101	\$ 14,797	\$ 15,144	\$ 14,884	\$ 15,636	\$ 15,791	\$ 15,224	\$ 19,928
Public works	5,318	5,170	5,451	5,157	5,557	6,453	7,058	5,816	7,832	6,217
Recreation	2,889	2,460	2,503	2,193	2,108	2,656	2,976	2,744	2,613	3,402
Community development	3,913	3,962	4,052	3,583	4,514	4,038	4,590	5,758	4,243	6,440
Admin/Community services	3,765	3,794	3,837	4,034	5,675	3,804	4,002	4,882	4,411	5,687
Interest on long-term activities	32	83	86	69	95	71	68	63	51	64
<b>Total governmental activities expenses</b>	<b>29,480</b>	<b>29,281</b>	<b>30,030</b>	<b>29,833</b>	<b>33,093</b>	<b>31,906</b>	<b>34,330</b>	<b>35,054</b>	<b>34,374</b>	<b>41,738</b>
Business-type activities:										
Sewer	4,810	4,438	4,520	4,386	4,529	4,574	4,789	4,607	6,754	4,970
Solid waste	1,574	1,826	717	341	355	366	347	376	438	461
Storm drain	188	199	200	213	232	165	215	0	1	1
<b>Total Business-type activities expenses</b>	<b>6,572</b>	<b>6,463</b>	<b>5,437</b>	<b>4,940</b>	<b>5,116</b>	<b>5,105</b>	<b>5,351</b>	<b>4,983</b>	<b>7,193</b>	<b>5,432</b>
<b>Total primary government expenses</b>	<b>\$ 36,052</b>	<b>\$ 35,744</b>	<b>\$ 35,467</b>	<b>\$ 34,773</b>	<b>\$ 38,209</b>	<b>\$ 37,011</b>	<b>\$ 39,681</b>	<b>\$ 40,037</b>	<b>\$ 41,567</b>	<b>\$ 47,170</b>
<b>Program Revenues</b>										
Governmental activities:										
Charges for services:										
Public safety	\$ 585	\$ 466	\$ 348	\$ 394	\$ 344	\$ 417	\$ 898	\$ 462	\$ 363	\$ 330
Public works	180	152	191	32	34	60	33	55	42	51
Recreation	1,472	1,498	1,763	1,808	1,865	1,952	2,167	2,123	2,070	2,021
Community development	1,867	2,954	2,650	3,260	7,431	5,196	3,625	3,412	3,112	4,589
Admin/Community services	969	1,097	1,061	875	947	942	954	1,033	1,082	950
Operating grants and contributions:										
Public safety	108	102	100	112	109	116	109	437	392	409
Public works	479	462	682	829	699	909	504	336	262	298
Recreation	4	-	-	-	-	-	-	2	5	5
Community development	48	56	168	21	59	36	343	8	148	170
Admin/Community services	6	131	64	36	58	6	-	-	-	-
Capital grants and contributions										
Public safety	-	-	-	-	-	-	-	-	-	-
Public works	978	985	711	897	492	747	498	1,522	807	641
Recreation	10	-	-	-	-	-	-	-	-	-
Community development	24	7	-	3,400	80	3	30	7	-	62
Admin/Community services	89	200	78	76	-	83	-	-	-	-
<b>Total governmental activities program revenues</b>	<b>6,819</b>	<b>8,110</b>	<b>7,816</b>	<b>11,740</b>	<b>12,118</b>	<b>10,467</b>	<b>9,161</b>	<b>9,397</b>	<b>8,283</b>	<b>9,526</b>

City of Los Altos

Changes in Net Position

Last Ten Fiscal Years

(accrual basis of accounting; amounts expressed in thousands)

	2008-09	2009-10	2010-11	2011-12	2012-13	2013-14	2014-15	2015-16	2016-17	2017-18
Business-type activities:										
Charges for services:										
Sewer	\$ 5,804	\$ 5,413	\$ 4,813	\$ 4,503	\$ 5,121	\$ 6,347	\$ 6,328	\$ 6,986	\$ 6,703	\$ 6,369
Solid waste	1,685	1,657	992	821	879	754	786	752	774	812
Storm drain	-	-	-	-	-	12	2	-	-	-
Total business-type activities program revenues	7,489	7,070	5,805	5,324	6,000	7,113	7,116	7,738	7,477	7,181
<b>Total primary government program revenues</b>	<b>\$ 14,308</b>	<b>\$ 15,180</b>	<b>\$ 13,621</b>	<b>\$ 17,064</b>	<b>\$ 18,118</b>	<b>\$ 17,580</b>	<b>\$ 16,277</b>	<b>\$ 17,135</b>	<b>\$ 15,760</b>	<b>\$ 16,707</b>
Net (expense)/revenue:										
Governmental activities	\$ (22,661)	\$ (21,171)	\$ (22,214)	\$ (18,093)	\$ (20,975)	\$ (21,439)	\$ (25,170)	\$ (25,657)	\$ (26,091)	\$ (32,212)
Business-type activities	917	607	368	384	884	2,008	1,766	2,755	284	1,749
<b>Total primary government net (expense)/revenue</b>	<b>\$ (21,744)</b>	<b>\$ (20,564)</b>	<b>\$ (21,846)</b>	<b>\$ (17,709)</b>	<b>\$ (20,091)</b>	<b>\$ (19,431)</b>	<b>\$ (23,404)</b>	<b>\$ (22,902)</b>	<b>\$ (25,807)</b>	<b>\$ (30,463)</b>
<b>General Revenues and Other Changes in Net Position</b>										
Governmental activities										
Taxes:										
Property taxes	\$ 12,759	\$ 13,051	\$ 12,794	\$ 13,302	\$ 14,130	\$ 15,586	\$ 17,480	\$ 18,776	\$ 19,863	\$ 21,429
Sales taxes	2,697	2,255	2,588	2,746	2,926	2,809	2,943	3,196	3,278	3,244
Utility users taxes	2,530	2,515	2,543	2,548	2,600	2,600	2,523	2,672	2,680	2,732
Other taxes	2,147	2,453	2,910	2,868	3,301	3,542	3,732	3,909	4,330	4,535
Franchise fees	1,458	1,437	1,814	1,731	1,770	1,905	1,808	2,029	2,083	2,207
Sale of Capital Assets-net	-	-	-	(545)	(8)	2,846	-	-	-	-
Interest income	760	341	275	115	174	99	200	438	233	320
Miscellaneous	201	286	388	131	382	212	1,124	435	454	452
Transfers	(200)	(239)	(65)	(247)	(232)	(152)	(196)	-	-	-
<b>Total governmental activities</b>	<b>22,352</b>	<b>22,099</b>	<b>23,247</b>	<b>22,649</b>	<b>25,043</b>	<b>29,447</b>	<b>29,614</b>	<b>31,455</b>	<b>32,921</b>	<b>34,919</b>
Business-type activities										
Interest income	160	53	71	37	10	-	-	-	-	-
Miscellaneous	-	-	-	-	-	28	40	96	40	70
Transfers	200	239	65	247	232	152	196	-	-	-
Total business-type activities	360	292	136	284	242	180	236	96	40	70
<b>Total primary government</b>	<b>\$ 22,712</b>	<b>\$ 22,391</b>	<b>\$ 23,383</b>	<b>\$ 22,933</b>	<b>\$ 25,285</b>	<b>\$ 29,627</b>	<b>\$ 29,850</b>	<b>\$ 31,551</b>	<b>\$ 32,961</b>	<b>\$ 34,989</b>
<b>Change in Net Position</b>										
Governmental activities	\$ (309)	\$ 928	\$ 1,033	\$ 4,556	\$ 4,068	\$ 8,008	\$ 4,444	\$ 5,798	\$ 6,830	\$ 2,707
Business-type activities	1,277	899	504	668	1,126	2,188	2,002	2,851	324	
<b>Total primary government</b>	<b>\$ 968</b>	<b>\$ 1,827</b>	<b>\$ 1,537</b>	<b>\$ 5,224</b>	<b>\$ 5,194</b>	<b>\$ 10,196</b>	<b>\$ 6,446</b>	<b>\$ 8,649</b>	<b>\$ 7,154</b>	<b>\$ 2,707</b>

Source:

City of Los Altos Finance Department

City of Los Altos  
Fund Balances - Governmental Funds  
Last Ten Fiscal Years  
(modified accrual basis of accounting; amounts expressed in thousands)  
(Pre GASB 54 Presentation - For Years Before 2011-12)

(Pre GASB 54 Presentation)	Fiscal Year									
	2008-09	2009-10	2010-11	2011-12	2012-13	2013-14	2014-15	2015-16	2016-17	2017-18
<b>General fund</b>										
Reserved	\$ 39	\$ 143	\$ 48	\$ 46	\$ 49	\$ 27,195	\$ 30,010	\$ 29,588	\$ 37,637	\$ 40,519
Unreserved/Unrestricted	7,650	6,908	7,836	7,439	8,453	1,433	4,789	8,535	6,039	4,875
<b>Total general fund</b>	<b>\$ 7,689</b>	<b>\$ 7,051</b>	<b>\$ 7,884</b>	<b>\$ 7,485</b>	<b>\$ 8,502</b>	<b>\$ 28,628</b>	<b>\$ 34,799</b>	<b>\$ 38,123</b>	<b>\$ 43,676</b>	<b>\$ 45,394</b>
<b>All other governmental funds</b>										
Restricted	\$ 3,472	\$ 3,399	\$ 2,780	\$ 3,926	\$ 7,406	\$ 364	\$ 364	\$ 364	\$ 364	\$ 364
Reserved, reported in:										
Special revenue funds	4,120	6,422	6,768	6,911	7,415	9,644	12,737	9,605	9,281	9,744
Capital projects funds	21,814	19,540	16,868	17,213	15,676	7,621	4,714	4,477	1,993	512
Debt service funds	(8)	-	-	-	-	-	-	-	-	-
<b>Total all other governmental funds</b>	<b>\$ 29,398</b>	<b>\$ 29,361</b>	<b>\$ 26,416</b>	<b>\$ 28,050</b>	<b>\$ 30,497</b>	<b>\$ 17,629</b>	<b>\$ 17,815</b>	<b>\$ 14,446</b>	<b>\$ 11,638</b>	<b>\$ 10,620</b>
<b>Total all governmental funds</b>	<b>\$ 37,087</b>	<b>\$ 36,412</b>	<b>\$ 34,300</b>	<b>\$ 35,535</b>	<b>\$ 38,999</b>	<b>\$ 46,257</b>	<b>\$ 52,614</b>	<b>\$ 52,569</b>	<b>\$ 55,314</b>	<b>\$ 56,014</b>

GASB 54 Presentation:(2017-18)	2017-18				
	General Fund	In Lieu Park Land	Capital Projects	Other Govt Funds	Total
Inventory & Prepaids	\$ (26,760)	\$ -	\$ -	\$ -	\$ (26,760)
Notes Receivable	\$ (1,895,206)				\$ (1,895,206)
Veteran Memorial	(9,986)				(9,986)
<b>Non-Spendable</b>	<b>(1,931,952)</b>	<b>-</b>	<b>-</b>	<b>-</b>	<b>(1,931,952)</b>
Debt Service				(364,179)	(364,179)
Special Revenue Programs and Projects		(5,253,528)		(4,490,006)	(9,743,534)
<b>Restricted</b>	<b>-</b>	<b>(5,253,528)</b>	<b>-</b>	<b>(4,854,185)</b>	<b>(10,107,713)</b>
Continuing CIPS					-
<b>Committed</b>	<b>-</b>	<b>-</b>	<b>-</b>	<b>-</b>	<b>-</b>
General Fund Reserve	(7,250,645)				(7,250,645)
OPEB	(1,500,000)				(1,500,000)
PERS Reserve	(4,000,000)				(4,000,000)
Technology	(2,403,554)				(2,403,554)
Capital Projects	(23,432,734)			(1,335,148)	(24,767,882)
<b>Assigned</b>	<b>(38,586,933)</b>	<b>-</b>	<b>-</b>	<b>(1,335,148)</b>	<b>(39,922,081)</b>
<b>Unassigned</b>	<b>(4,874,898)</b>		823,098		<b>(4,051,800)</b>
<b>Total Fund Equity</b>	<b>\$ (45,393,783)</b>	<b>\$ (5,253,528)</b>	<b>\$ 823,098</b>	<b>\$ (6,189,333)</b>	<b>\$ (56,013,546)</b>

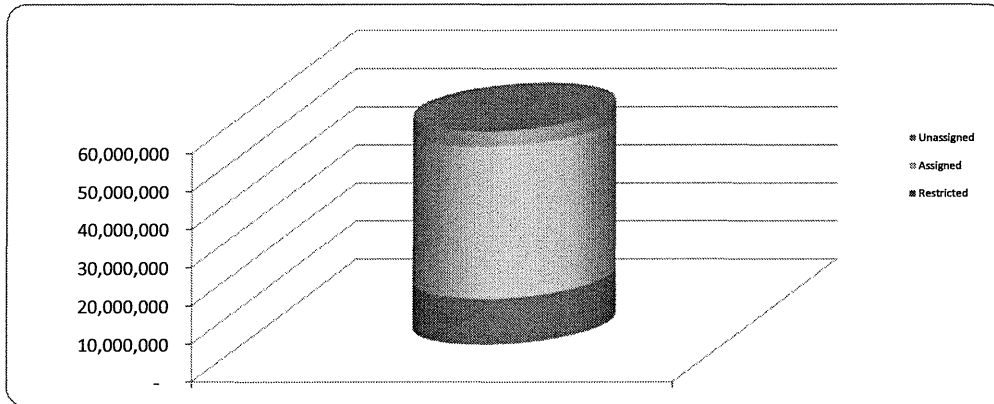

Source:  
City of Los Altos Finance Department