

# 163 DEL MONTE AVENUE

## LOS ALTOS, CA 94022

### NEW TWO STORY RESIDENCE

PLANNING PERMIT SUBMISSION SET:

**kylechan**  
 ARCHITECT  
 5205 PROSPECT ROAD  
 SUITE 135-120,  
 SAN JOSE, CA 95129  
 510-396-9731  
 www.kylechan.com  
 kyle@kylechan.com

PLANNING REVISED SET  
 4.19.2019

Sheet Revisions:  
 ▲

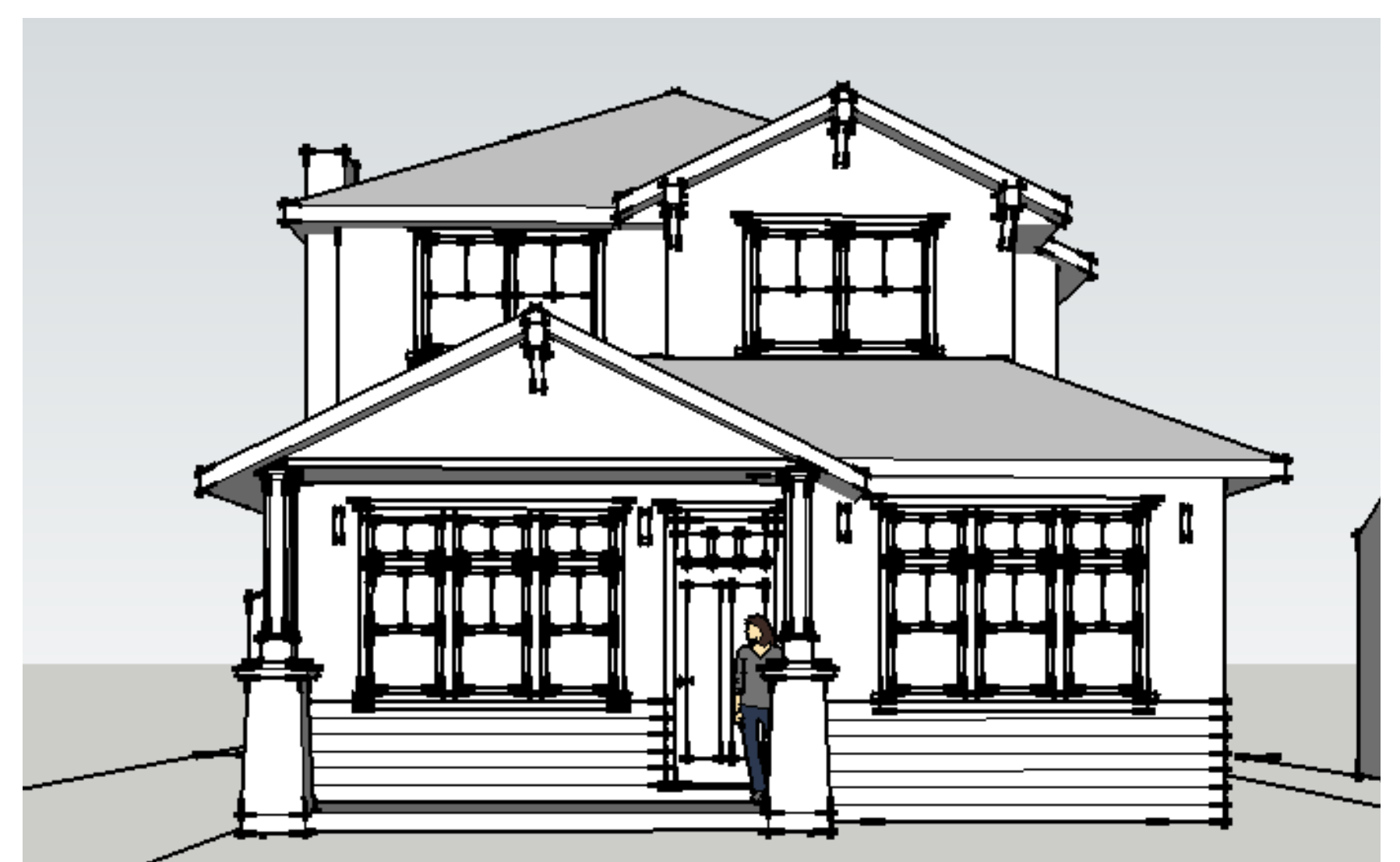

WU RESIDENCE  
 NEW RESIDENCE  
 163 DEL MONTE AVENUE  
 LOS ALTOS, CA 94022

#### PROJECT TEAM

**OWNER**  
 DEI WU  
 163 DEL MONTE AVE  
 LOS ALTOS, CA 94022  
 408-204-4833  
 blairewu@gmail.com

**ARCHITECT**  
 KYLE CHAN, ARCHITECT  
 5205 PROSPECT ROAD, #135-120  
 SAN JOSE, CA 95129  
 PH: 510-396-9731  
 kyle@kylechan.com

**SURVEYOR / CIVIL ENGINEER**  
 OSCAR OSUNA  
 GREENBLUEARTH, INC.  
 408-772-4361  
 OSUNAENGINEERING@GMAIL.COM

**LANDSCAPE ARCHITECT**  
 AMY MEARS  
 650 559 1920 O  
 650 575 7077 C  
 amymears@yahoo.com  
 http://amymearsdesign.com

**GENERAL CONTRACTOR**  
 TO BE DETERMINED

#### VICINITY MAP

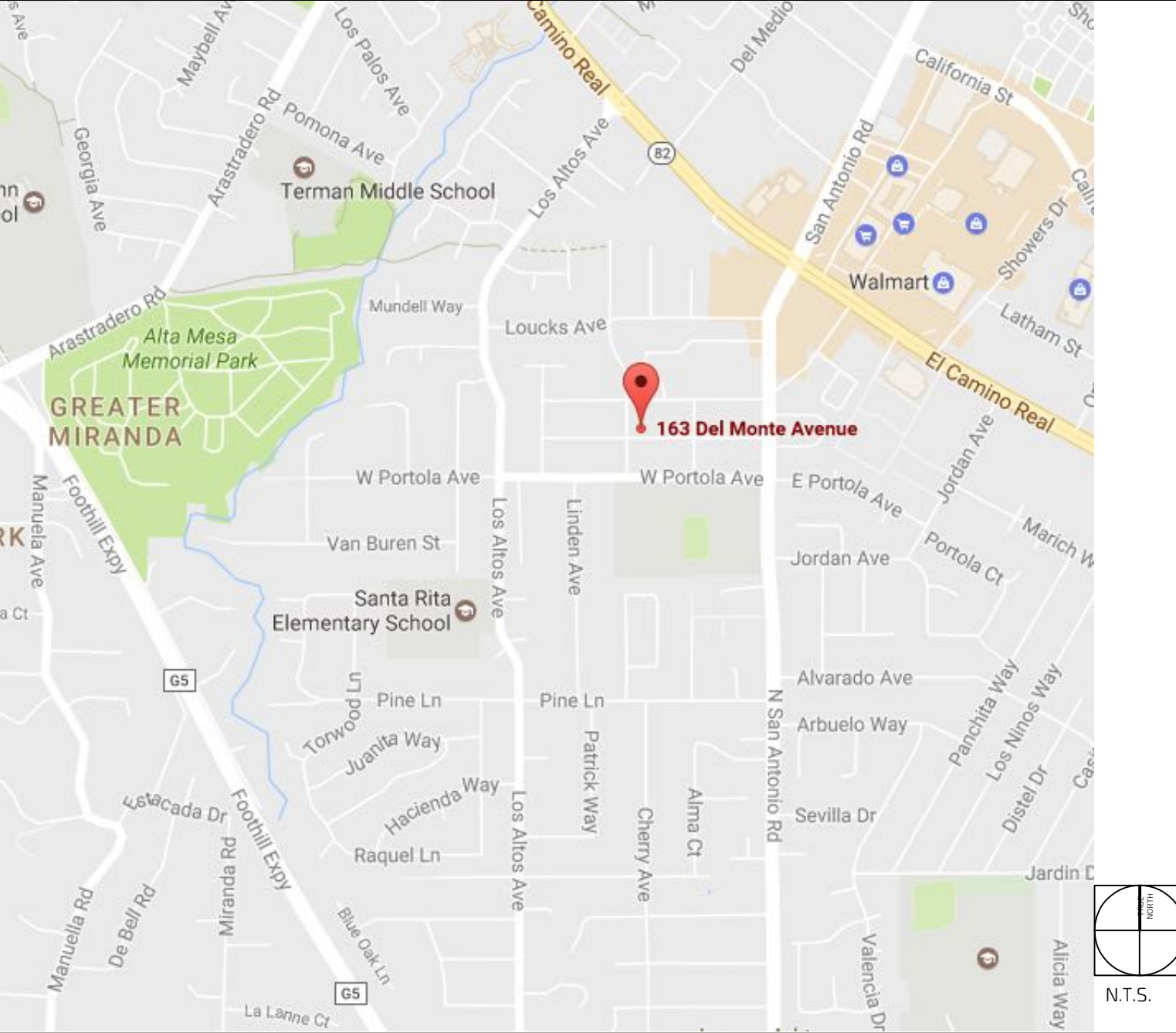

#### ZONING INFORMATION

ZONING COMPLIANCE			
	Existing	Proposed	Allowed/Required
<b>LOT COVERAGE:</b> <i>Land area covered by all structures that are over 6 feet in height</i>	1,851 square feet (31.5%)	1,536.9 square feet (26.2%)	1,762.5 square feet (30%)
<b>FLOOR AREA:</b> <i>Measured to the outside surfaces of exterior walls</i>	1,851 square feet (31.5%)	1ST FLR: 1,235.9 SF 2ND FLR: 819.9 SF TOTAL: 2,055.8 SF (35%)	2,056.3 square feet (35%)
<b>SETBACKS:</b>			
Front	24'-0" feet	35' feet	25' feet
Rear	11' feet	34'-0" feet	25' feet
Right side (1 <sup>st</sup> /2 <sup>nd</sup> )	5'-0" feet/NA feet	5' feet/10' feet	5' feet/10' feet
Left side (1 <sup>st</sup> /2 <sup>nd</sup> )	17' feet/NA feet	5' feet/10' feet	5' feet/10' feet
<b>HEIGHT:</b>	11' feet	24'-0" feet	27' feet

SQUARE FOOTAGE BREAKDOWN			
	Existing	Change in	Total Proposed
<b>HABITABLE LIVING AREA:</b> <i>Includes habitable basement areas</i>	1,367 square feet	-688.8 square feet	2,055.8 square feet
<b>NON-HABITABLE AREA:</b> <i>Does not include covered porches or open structures</i>	484 square feet	-258.3 square feet	225.7 square feet

LOT CALCULATIONS	
<b>NET LOT AREA:</b>	5,875 square feet
<b>FRONT YARD HARDSCAPE AREA:</b> <i>Hardscape area in the front yard setback shall not exceed 50%</i>	462 square feet (39%)
<b>LANDSCAPING BREAKDOWN:</b>	
Total hardscape area (existing and proposed):	2,633.7 sq ft
Existing softscape (undisturbed) area:	0 sq ft
New softscape area:	3,241.3 sq ft
<i>Sum of all three should equal the site's net lot area</i>	

#### PROJECT INFORMATION

**PROJECT DESCRIPTION:**  
 1. PROPOSE A NEW 2-STORY BUILDING  
 2. PROPOSE A NEW 1-CAR PARKING GARAGE.

**ZONING DISTRICT:** R-1-10

**APN:** 167-17-032

**CONSTRUCTION TYPE:** V-B

**OCCUPANCY:** R-3 / U

**BUILDING CODES:**  
 2016 CBC (BASED ON 2015 IBC)  
 2016 CRC (BASED ON 2015 IRC)  
 2016 CEC (BASED ON 2014 NEC)  
 2016 CMC (BASED ON 2015 UMC)  
 2016 CPC (BASED ON 2015 UPC)  
 2016 CALIFORNIA ENERGY CODE  
 2016 CFC (BASED ON 2015 IFC)  
 2016 CALIFORNIA GREEN BUILDING STANDARDS CODE (CALGREEN)  
 LOS ALTOS CITY MUNICIPAL CODE  
 ALL APPLICABLE LOCAL, COUNTY, STATE AND FEDERAL CODES, LAWS & REGULATIONS

**FIRE SPRINKLER:**  
 A RESIDENTIAL FIRE SPRINKLER SYSTEM IS REQUIRED IN ACCORDANCE WITH NFPA 13D AND STATE AND LOCAL REQUIREMENTS  
 FIRE SPRINKLER SYSTEM TO BE APPROVED UNDER A SEPARATE PERMIT.

#### DRAWING INDEX

- ARCHITECTURAL**  
 A0.1 PROJECT INFO / SITE PLAN
- CIVIL**  
 1 OF 1 SITE SURVEY  
 C1 GRADING & DRAINAGE PLAN  
 C2 CONSTRUCTION DETAILS  
 C3 EROSION CONTROL PLAN
- A0.2** STREETScape DIAGRAM  
**A0.5** SITE PLAN / ROOF PLAN / AREA CALCULATIONS  
**A2.1** FIRST / SECOND FLOOR PROPOSED PLANS  
**A3.1** PROPOSED ELEVATIONS  
**A3.2** PROPOSED ELEVATIONS  
**A3.3** GARAGE FLOOR PLANS/ ELEVATIONS/ SECTIONS  
**A8.1** SECTIONS
- LANDSCAPE**  
 L1 LANDSCAPE PLAN  
 L2 ILLUSTRATED LANDSCAPE PLAN

PLANNING SET  
 NOT FOR CONSTRUCTION

COVER SHEET

A0.1

PROJECT NUMBER: 1619  
 163 DEL MONTE AVE

Date: 4/16/19  
 File name: 1619\_A0.1\_V01.dwg

**LEGEND**

---	EXISTING CONTOUR LINE
---	NATURAL GRADE CONTOUR LINE
⊙	FOUND CITY MONUMENT BOX, OR AS NOTED
●	FOUND IRON PIPE AS NOTED
○	FOUND REBAR AS NOTED
---	BOUNDARY OF PROPERTY SURVEYED
( )	RECORD INFORMATION
---	CENTERLINE
△	CURB INLET
---	CURB LINE
---	DRIVEWAY APRON
○	ELECTROLIER
-x-x-x-	FENCE
⊕	FIRE HYDRANT
■	FLAT GRATE INLET
—O.H. PWR—	OVERHEAD POWER LINE
—O.H. TEL—	OVERHEAD TELEPHONE LINE
SS	SANITARY SEWER LINE
○	SANITARY SEWER MANHOLE
⊕	SANITARY SEWER CLEANOUT
—	SIGN
SD	STORM DRAIN LINE
⊙	STORM DRAIN MANHOLE
□	UTILITY BOX
○	UTILITY POLE
W	WATER LINE
■	WATER METER
∞	WATER VALVE
⊕	ELECTRIC METER
⊕	WATER HEATER
⊕	GAS

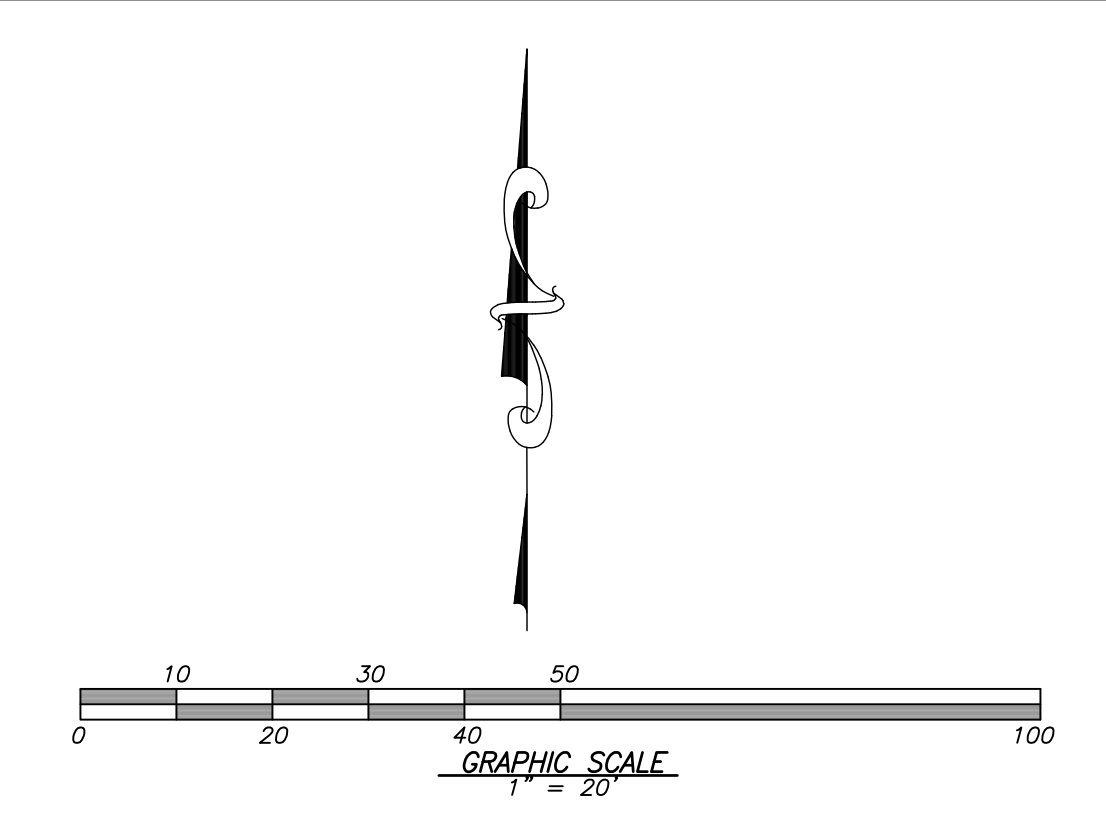
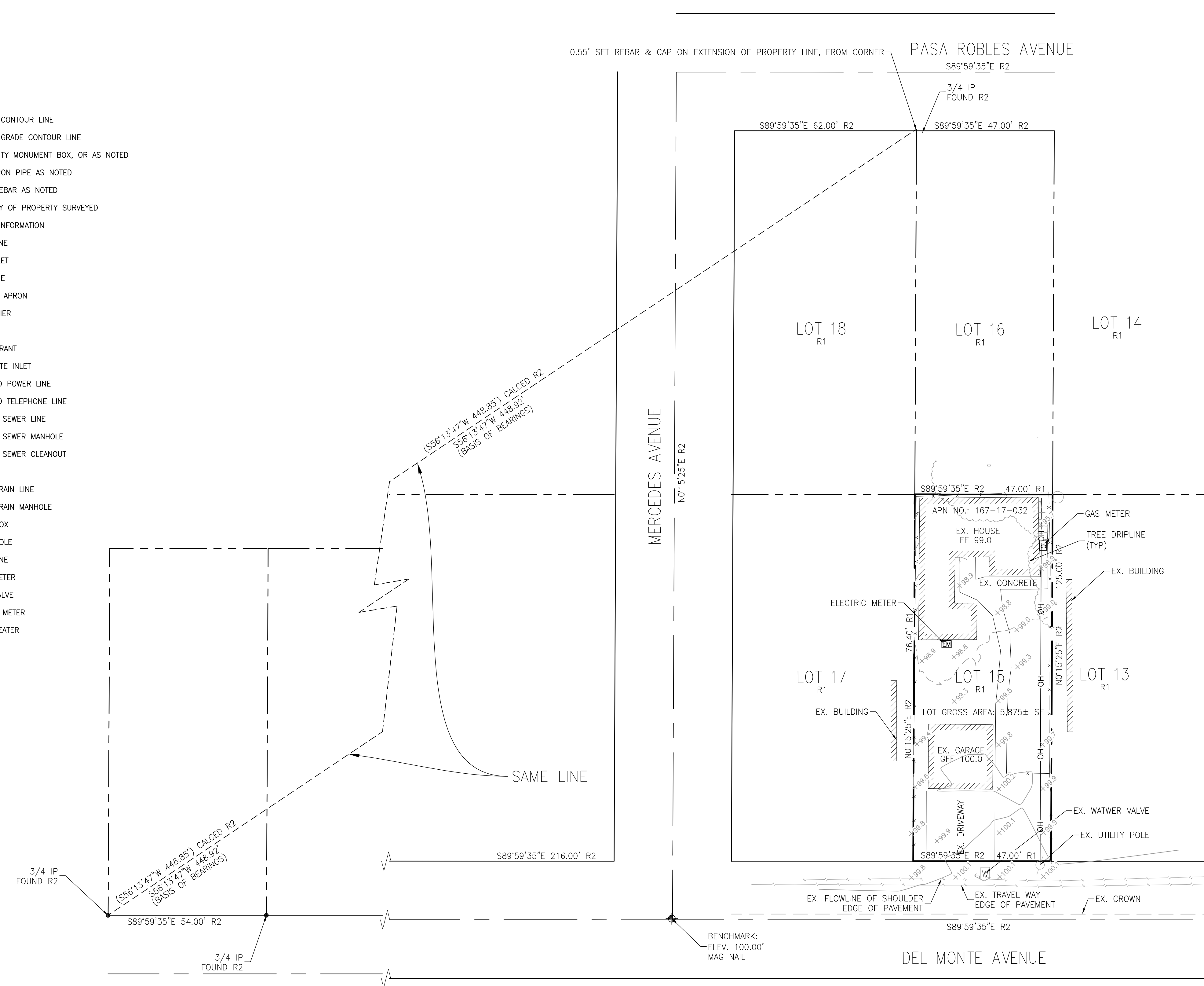

**BASIS OF BEARINGS**  
 THE BEARING SOUTH 68°55'50" WEST OF THE MONUMENT LINE OF PASA ROBLES AVENUE AND IP FOUND ON DEL MONTE AVENUE AS CALCULATED ON THE CORNER RECORD #2314, SANTA CLARA COUNTY RECORDS, AND AS FOUND MONUMENTED, WAS TAKEN AS THE BASIS OF BEARING FOR THIS SURVEY.

**REFERENCES:**  
 R1 LOS ALTOS PARK U-M-30  
 R2 CORNER RECORD #2314

**BENCH MARK**  
 DESCRIPTION: ASSUMED BENCHMARK, MAG NAIL ON STREET, NEAR THE SOUTHERLY EASTERLY CORNER OF LOT AS SHOWN: ELEV.: 100.00'

**ABBREVIATIONS**

APN	ASSESSOR'S PARCEL NUMBER
BM	BENCH MARK
CATV	CABLE TELEVISION OVERHEAD
D	CURVE DELTA
DRWY	DRIVEWAY
DS	DOWNSPOUT
FL	FLOW LINE ELEVATION
IP	IRON PIPE
L	CURVE LENGTH
R#	REFERENCE DOCUMENT
M-M	MONUMENT TO MONUMENT
O.H. PWR	OVERHEAD POWER LINE
O.H. TEL	OVERHEAD TELEPHONE LINE
PCL	PARCEL
P.M.	PARCEL MAP
PTN	PORTION
R	RADIUS
SD	STORM DRAIN
SS	SANITARY SEWER
TC	TOP OF CURB ELEVATION
TEMP.	TEMPORARY
PUE	PUBLIC UTILITY EASEMENT
WLE	WATER LINE EASEMENT



- NOTES:**
- DISTANCES AND DIMENSIONS ARE SHOWN IN FEET AND DECIMALS THEREOF.
  - THE DISTINCTIVE BORDER LINE DENOTES THE BOUNDARY.
  - TREES SPECIES NAMES ARE APPROXIMATE, AND LABELED BY THEIR COMMON NAME TO THE BEST OF OUR KNOWLEDGE. IT IS NOT BASED ON AN ARBORIST REPORT.
  - THIS MAP REPRESENTS TOPOGRAPHY OF THE SURFACE FEATURES ONLY. THE BOUNDARY SHOWN ARE TAKEN FROM RECORDED MAPS AND DEEDS FOR REFERENCE ONLY.
  - UNLESS SPECIFIED ON THIS MAP, LOCATIONS OF THE UNDERGROUND AND OVERHEAD UTILITIES ARE NEITHER INTENDED NOR IMPLIED. FOR THE LOCATIONS OF UNDERGROUND UTILITIES CALL "USA" (1-800-642-2440).
  - BUILDING FOOTPRINTS ARE SHOWN AT GROUND LEVEL.
  - FINISH FLOOR ELEVATION TAKEN AT DOOR THRESHOLD (EXTERIOR).
  - A TITLE REPORT FOR THE SUBJECT PROPERTY HAS NOT BEEN EXAMINED BY GREENBLUEARTH, INC.. OTHER EASEMENTS OF RECORD MAY EXIST THAT ARE NOT SHOWN ON THIS MAP.

DATE		REVISIONS	
DATE	5-11-17	AS SHOWN	O.OSUNA
SCALE		DRAWN BY	O.OSUNA
		CHECKED BY	O.O.
BOUNDARY AND TOPOGRAPHIC MAP			
LANDS OF WU & HE			
163 DEL MONTE AVE			
LOS ALTOS, CALIFORNIA			
JOB NO.	1386		
SHEET	1		
OF	1		

**GRADING & DRAINAGE NOTES:**

NOTE: THIS DRAWING IS APPROVED SUBJECT TO:

- ALL GRADING IS SUBJECT TO OBSERVATION BY THE CITY PERMITTEE OR REPRESENTATIVE SHALL NOTIFY THE CITY OF LOS ALTOS DEPARTMENT OF PUBLIC WORKS PROJECT INSPECTOR AT LEAST 48 HOURS BEFORE START OF ANY GRADING.
- APPROVAL OF THIS PLAN APPLIES ONLY TO (A) THE EXCAVATION, PLACEMENT, AND COMPACTION OF NATURAL EARTH MATERIALS, (B) THE INSTALLATION OF ON-SITE (I.E. PRIVATE PROPERTY) STORM WATER CONVEYANCE AND TREATMENT FACILITIES THAT ARE OUTSIDE OF THE 5-FOOT BUILDING ENVELOPE, AND (C) THE INSTALLATION OF RETAINING STRUCTURES. THIS APPROVAL DOES NOT CONFER ANY RIGHTS OF ENTRY TO EITHER PUBLIC PROPERTY OR THE PRIVATE PROPERTY OF OTHERS. APPROVAL OF THIS PLAN ALSO DOES NOT CONSTITUTE APPROVAL OF ANY IMPROVEMENTS WITH THE EXCEPTION OF THOSE LISTED ABOVE. PROPOSED IMPROVEMENTS, WITH THE EXCEPTION OF THOSE LISTED ABOVE, ARE SUBJECT TO REVIEW AND APPROVAL BY THE RESPONSIBLE AUTHORITIES AND ALL OTHER REQUIRED PERMITS SHALL BE OBTAINED.
- UNLESS OTHERWISE NOTED ON THE PLAN, ANY DEPICTION OF A RETAINING STRUCTURE ON THIS PLAN SHALL NOT CONSTITUTE APPROVAL FOR CONSTRUCTION OF THE RETAINING STRUCTURE UNLESS A SEPARATE STRUCTURAL REVIEW, BY THE DEPARTMENT OF PUBLIC WORKS IS COMPLETED AND APPROVED.
- IT SHALL BE THE RESPONSIBILITY OF THE PERMITTEE OR AGENT TO IDENTIFY, LOCATE AND PROTECT ALL UNDERGROUND FACILITIES.
- THE PERMITTEE OR AGENT SHALL MAINTAIN THE STREETS, SIDEWALKS AND ALL OTHER PUBLIC RIGHTS-OF-WAY IN A CLEAN, SAFE AND USABLE CONDITION. ALL SPILLS OF SOIL, ROCK OR CONSTRUCTION DEBRIS SHALL BE REMOVED FROM THE PUBLICLY OWNED PROPERTY DURING CONSTRUCTION AND UPON COMPLETION OF THE PROJECT. ALL ADJACENT PROPERTY, PRIVATE OR PUBLIC SHALL BE MAINTAINED IN A CLEAN, SAFE AND USABLE CONDITION.
- ALL GRADING SHALL BE PERFORMED IN SUCH A MANNER AS TO COMPLY WITH THE STANDARDS ESTABLISHED BY THE AIR QUALITY MANAGEMENT DISTRICT FOR AIRBORNE PARTICULATES.
- IN THE EVENT THAT HUMAN REMAINS AND/OR CULTURAL MATERIALS ARE FOUND, ALL PROJECT-RELATED CONSTRUCTION SHOULD CEASE WITHIN A 100-FOOT RADIUS. THE CONTRACTOR SHALL, PURSUANT TO SECTION 7050.5 OF THE HEALTH AND SAFETY CODE, AND SECTION 5097.94 OF THE PUBLIC RESOURCES CODE OF THE STATE OF CALIFORNIA, NOTIFY THE MARIN COUNTY CORONER IMMEDIATELY.
- THIS PLAN DOES NOT APPROVE THE REMOVAL OF TREES. APPROPRIATE TREE REMOVAL PERMITS AND METHODS OF TREE PRESERVATION SHOULD BE OBTAINED FROM THE CITY'S PLANNING DEPARTMENT AND THE CITY ARBORIST.
- FOR NON-RESIDENTIAL PROJECTS, ANY NON-HAZARDOUS EXPORT RESULTING FROM PROJECT RELATED EXCAVATION OR LAND CLEARING SHALL BE 100% REUSED AND RECYCLED PER CALIFORNIA GREEN BUILDING STANDARDS CODE SECTION 5.408.
- ALL GRADING WORK SHALL CONFORM TO THE RECOMMENDATIONS OF THE PROJECT GEOTECHNICAL REPORT AND/OR THE PROJECT SOIL ENGINEER. ALL GRADING WORK SHALL BE OBSERVED AND APPROVED BY THE SOIL ENGINEER.
- THE SOIL ENGINEER SHALL BE NOTIFIED AT LEAST 48 HOURS BEFORE BEGINNING ANY GRADING. UNOBSERVED AND/OR UNAPPROVED GRADING WORK SHALL BE REMOVED AND REPLACED UNDER OBSERVATION.
- PERIMETER BUILDING GRADES SHALL SLOPE AWAY FROM BUILDINGS AT LEAST 5% MINIMUM
- ALL DOWNSPOUTS SHALL HAVE SPLASH BOXES AS SHOWN ON THE GRADING AND DRAINAGE PLAN. DIRECTION OF THE FLOW SHALL BE AWAY FROM THE BUILDING.

**BENCH MARK**

DESCRIPTION: ASSUMED BENCHMARK, MAG NAIL ON STREET, NEAR THE SOUTHERLY EASTERLY CORNER OF LOT AS SHOWN: ELEV.: 100.00'

**EARTH WORK QUANTITIES**

CUT: 12 CY  
 FILL: 130 CY  
 EXPORT: 0 CY  
 IMPORT: 118 CY

NOTE: EARTHWORK QUANTITIES SHOWN ARE APPROXIMATE. IT SHALL BE THE CONTRACTOR'S RESPONSIBILITY TO INDEPENDENTLY ESTIMATE QUANTITIES FOR HIS/HER OWN USE. THE PAD OF THE HOUSE IS NOT INCLUDED

**ABBREVIATIONS**

- |                                |                                      |
|--------------------------------|--------------------------------------|
| AC = ASPHALT CONCRETE          | LP = LOW POINT                       |
| AD = AREA DRAIN                | PAD = PAD ELEVATION                  |
| BC = BEGIN CURVE               | PCC = PORTLAND CEMENT CONCRETE       |
| BS = BOTTOM OF STAIR           | PL = PROPERTY LINE                   |
| BU = BUBBLE UP                 | PV = PAVEMENT GRADE                  |
| BVC = BEGIN VERTICAL CURVE     | PVC = POLYVINYL CHLORIDE PIPE        |
| BRW = BOTTOM OF RETAINING WALL | PVI = POINT OF VERTICAL INTERSECTION |
| CB = CATCH BASIN               | RCP = REINFORCED CONCRETE PIPE       |
| CL = CENTERLINE                | ROW = RIGHT OF WAY                   |
| CO = CLEANOUT                  | S=00+ = SLOPE                        |
| DS = DOWNSPOUT WITH SPLASH BOX | SD = STORM DRAIN                     |
| EC = END CURVE                 | SDMH = STORM DRAIN MANHOLE           |
| ELEV. = ELEVATION              | SG = SUBGRADE ELEVATION              |
| EVC = END VERTICAL CURVE       | SS = SANITARY SEWER                  |
| EX = EXISTING                  | SSMH = SANITARY SEWER MANHOLE        |
| F/C = FACE OF CURB             | STA = STATION                        |
| FF = FINISHED FLOOR ELEVATION  | TC = TOP OF CURB                     |
| FL = FIRE HYDRANT              | TF = TOP OF FENCE                    |
| FL = FLOW LINE                 | TRW = TOP OF RETAINING WALL          |
| GB = GRADE BREAK               | TS = TOP OF STAIR                    |
| GFF = GARAGE FINISH FLOOR      | TW = TOP OF WALL                     |
| HP = HIGH POINT                | VCP = VITRIFIED CLAY PIPE            |
| HC = HANDICAP UNIT             | WM = WATER METER                     |
| INV = INVERT                   | WV = WATER VALVE                     |

**LEGEND**

DESCRIPTION	SYMBOL
BOUNDARY LINE	---
LOT LINE	---
EXEMPTION LINE	---
SIDEWALK	---
WOOD FENCE	X-X
CHAIN LINK FENCE	---O---
RETAINING WALL	--- ---
DRIVEWAY DRAIN INLET	--- ---
AREA DRAIN	--- ---
DROP INLET	--- ---
MONUMENT	--- ---
FIRE HYDRANT	--- ---
ELECTROVALVE	--- ---
WATER METER	--- ---
AC UNIT	--- ---
SANITARY SEWER LATERAL	--- ---
STORM DRAIN	SD
SANITARY SEWER	SS
STREET LIGHT CONDUITS	SL
WATER	W
JOINT TRENCH	JT
HOUSE SERVICE	SVC
SLOPE ARROW	---
EXISTING CONTOUR	---
PROPOSED CONTOUR	---
OVERLAND RELEASE	---
DIRECTION OF SURFACE DRAINAGE	---
5% SLOPE AWAY FROM BUILDING	---
GAS LINE	---
OVERHEAD ELECTRICAL LINE	---
UNDERGROUND ELECTRICAL LINE	---

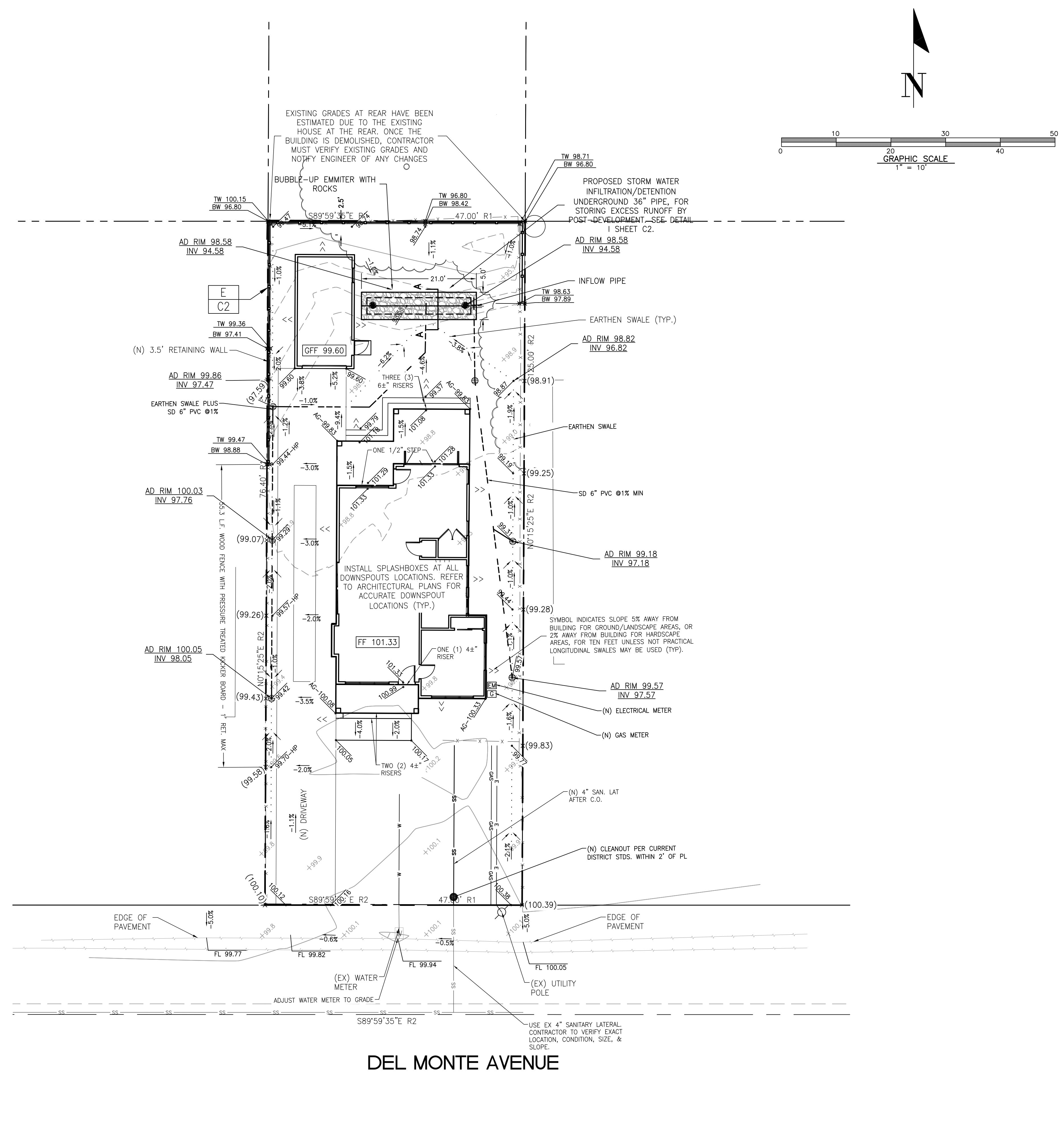

**DEL MONTE AVENUE**

REVISIONS	DATE	CITY	BY

**OSUNA ENGINEERING INC.**  
 Planning Surveying Civil Engineering  
 CONSULTING CIVIL ENGINEERS & LAND SURVEYORS  
 TEL: (408) 772-4381  
 117 BERNAL RD. STE. 70-336  
 SAN JOSE, CA 95119  
 info@osunaengineering.com

**GRADING & DRAINAGE PLAN**  
**163 DEL MONTE AVENUE**  
 CALIFORNIA  
 Project No.: 1386 | Design: J.O. | Check: O.C. | Date: 3/14/19

SHEET  
**C1**  
 OF 3 SHEETS

CONTRACTOR AGREES THAT HE SHALL ASSUME SOLE AND COMPLETE RESPONSIBILITY FOR JOB SITE CONDITIONS DURING THE COURSE OF CONSTRUCTION OF THIS PROJECT, INCLUDING BUT NOT LIMITED TO NORMAL WORKING HOURS; AND THAT THE CONTRACTOR SHALL BE RESPONSIBLE FOR OBTAINING ALL NECESSARY PERMITS AND APPROVALS FROM THE CITY OF LOS ALTOS, CALIFORNIA, AND THE COUNTY OF SAN JOSE, CALIFORNIA, AND SHALL BE RESPONSIBLE FOR THE PERFORMANCE OF WORK ON THIS PROJECT, EXCEPTING FOR LIABILITY ARISING FROM THE SOLE NEGLIGENCE OF THE OWNER OR THE ENGINEER.

CONTRACTOR AGREES THAT HE SHALL ASSUME SOLE AND COMPLETE RESPONSIBILITY FOR JOB SITE CONDITIONS DURING THE COURSE OF CONSTRUCTION OF THIS PROJECT, INCLUDING THE SAFETY OF ALL PERSONS AND PROPERTY THAT THIS REQUIREMENT SHALL BE LIMITED TO NORMAL WORKING HOURS; AND THAT THE CONTRACTOR SHALL BE RESPONSIBLE FOR THE SAFETY OF ALL PERSONS AND PROPERTY THAT THIS REQUIREMENT SHALL BE LIMITED TO NORMAL WORKING HOURS; AND THAT THE CONTRACTOR SHALL BE RESPONSIBLE FOR THE SAFETY OF ALL PERSONS AND PROPERTY THAT THIS REQUIREMENT SHALL BE LIMITED TO NORMAL WORKING HOURS.

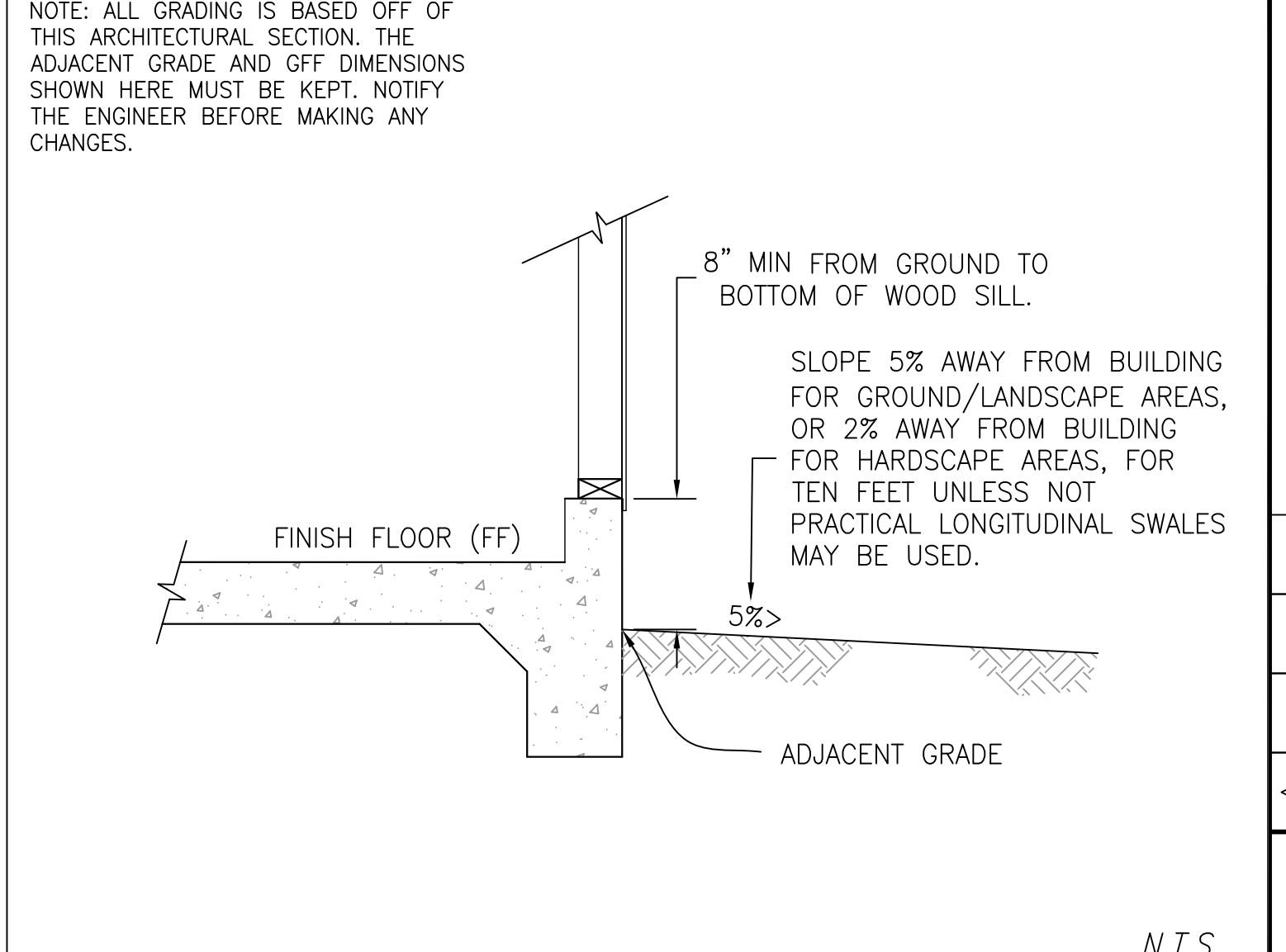
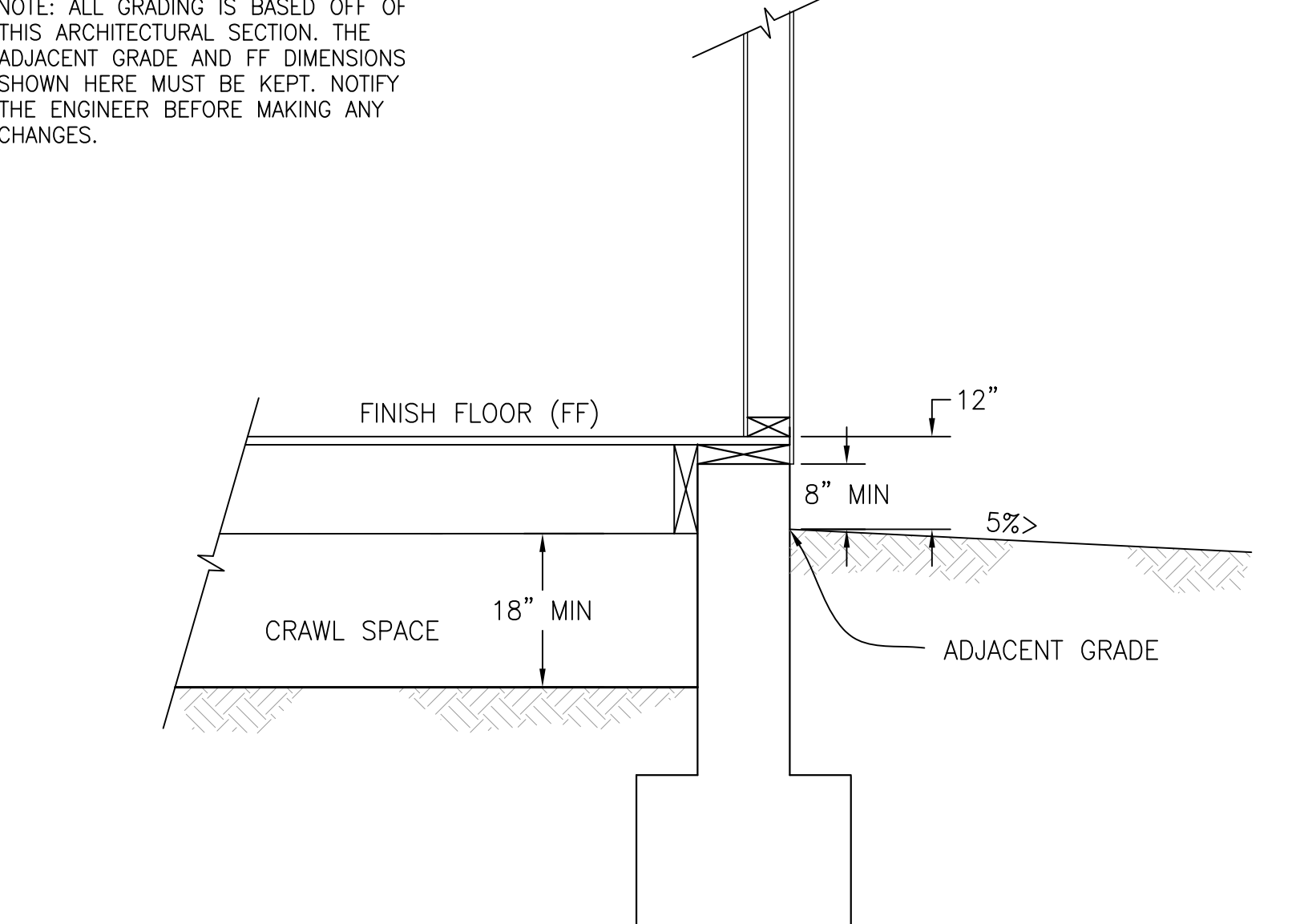
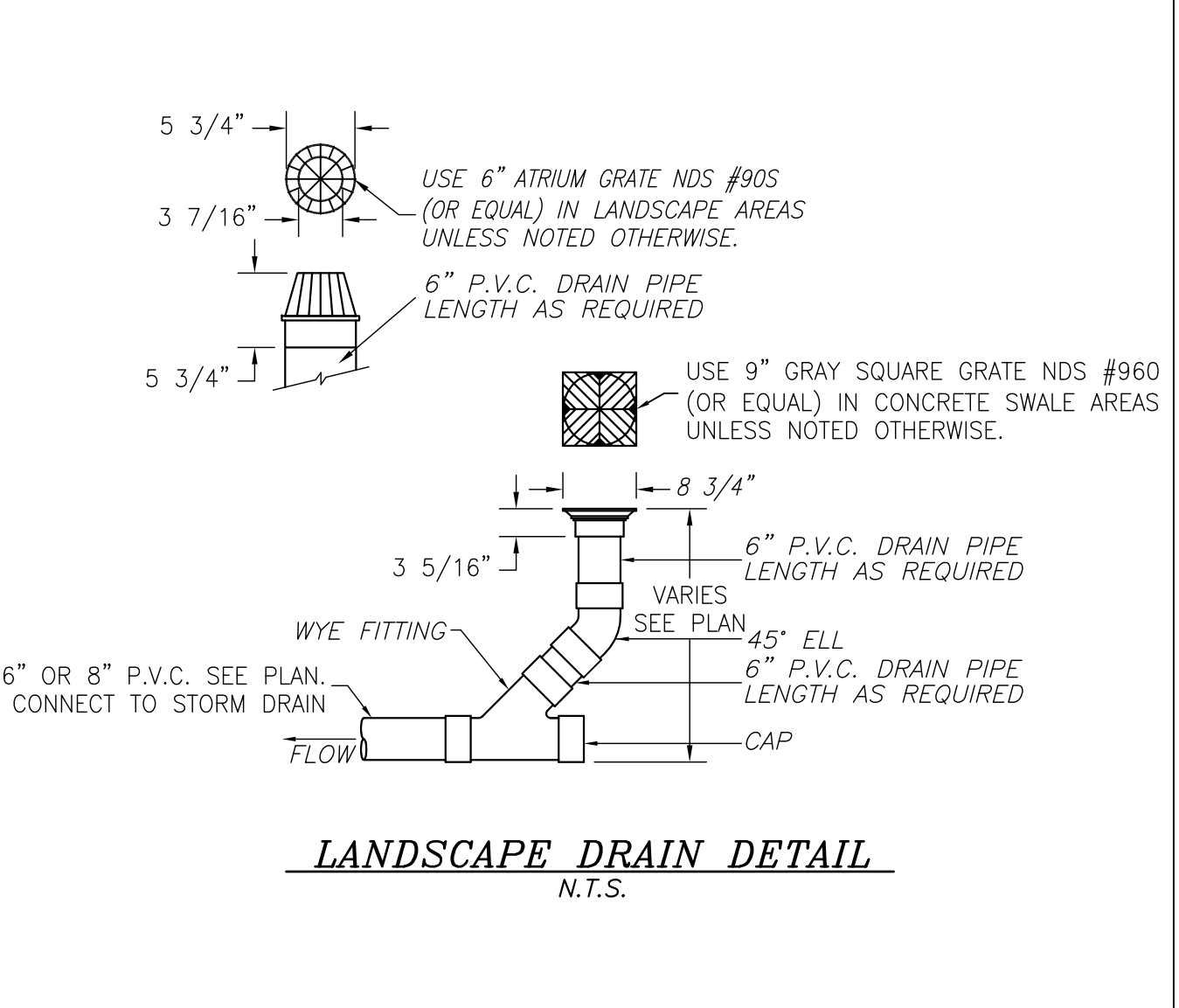
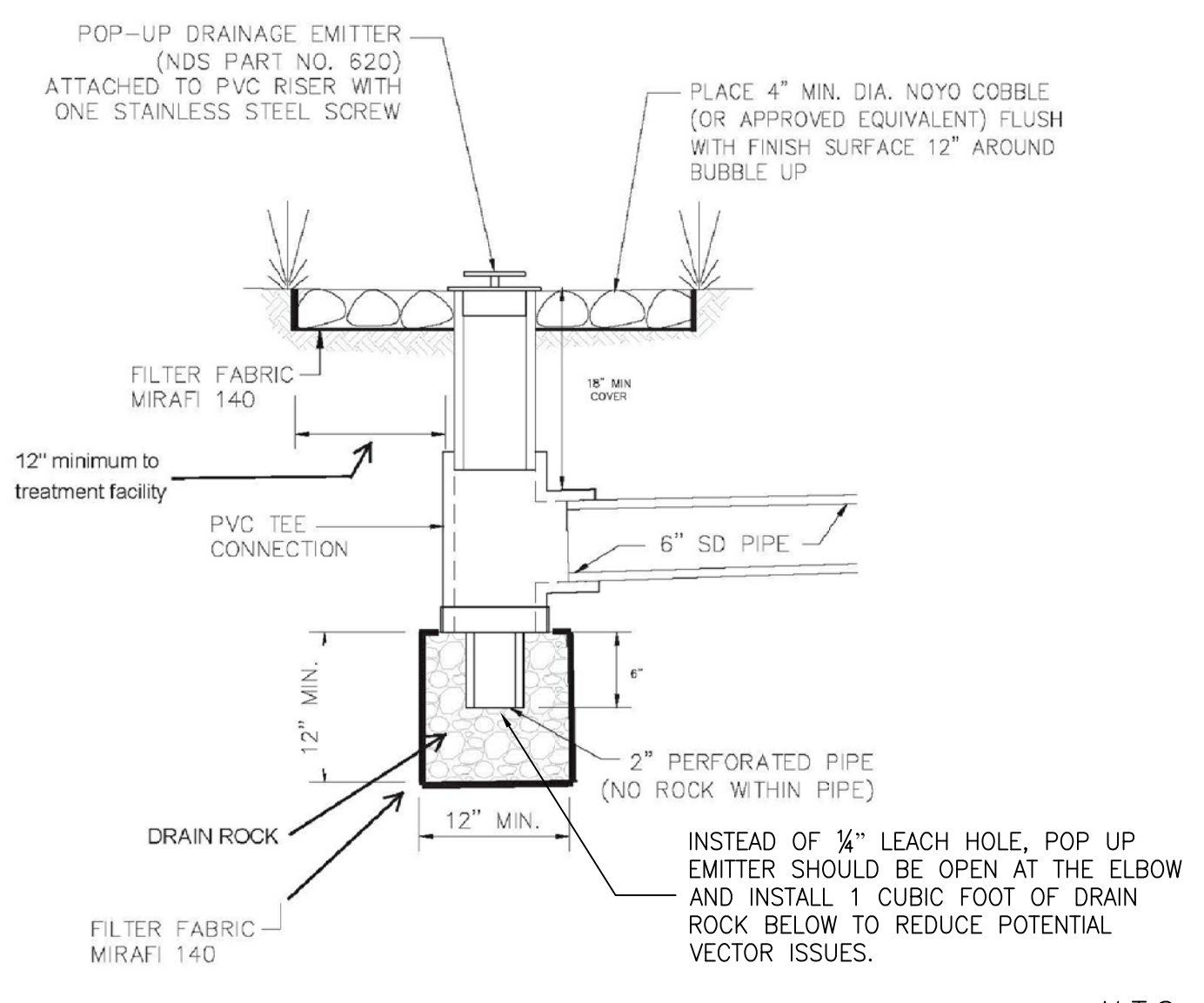

A BUBBLE-UP EMITTER DETAIL

B AREA DRAIN DETAIL

C TYPICAL FOUNDATION/FF/GROUND SECTION

D TYPICAL FOUNDATION/GFF/GROUND SECTION

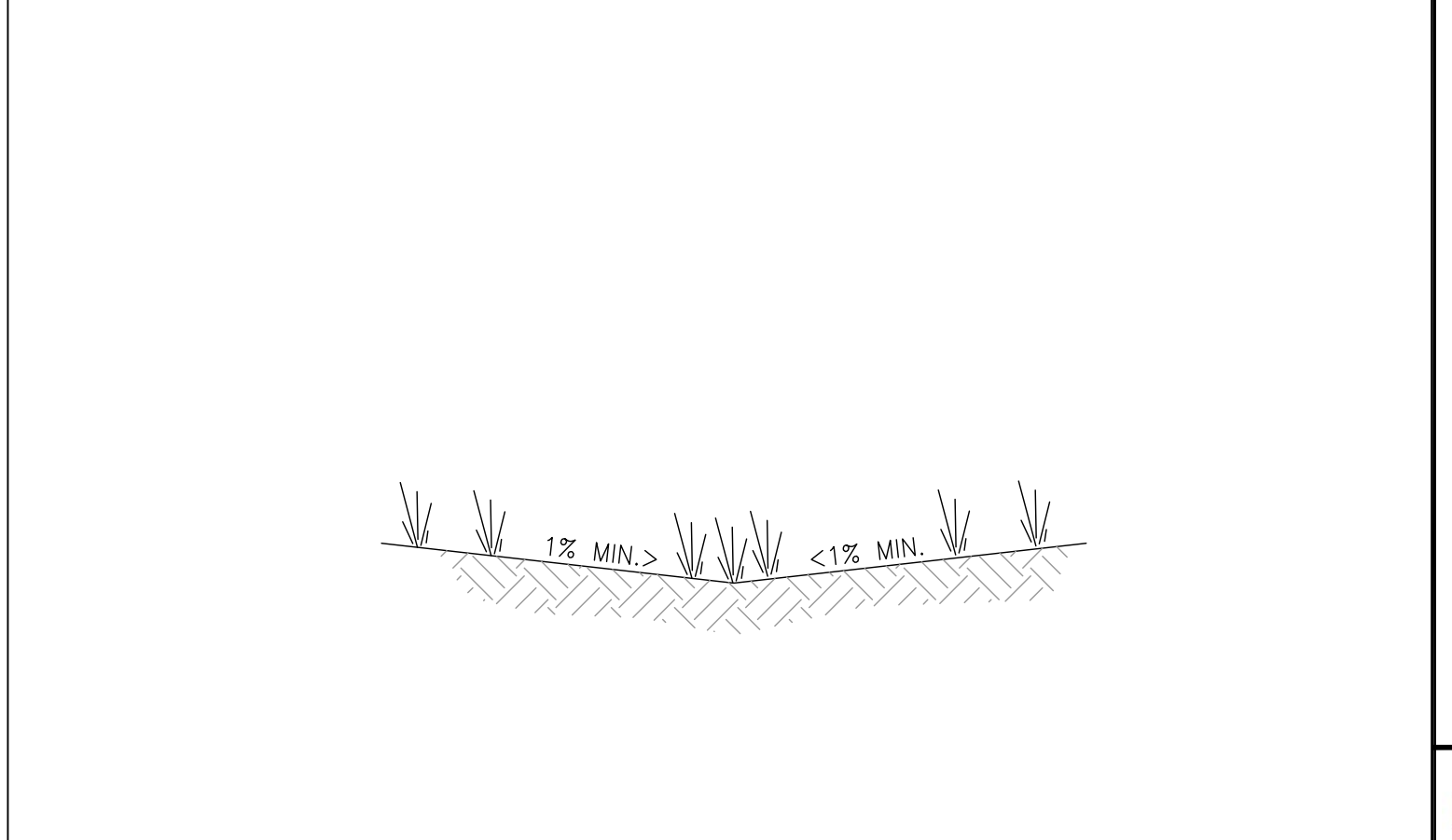
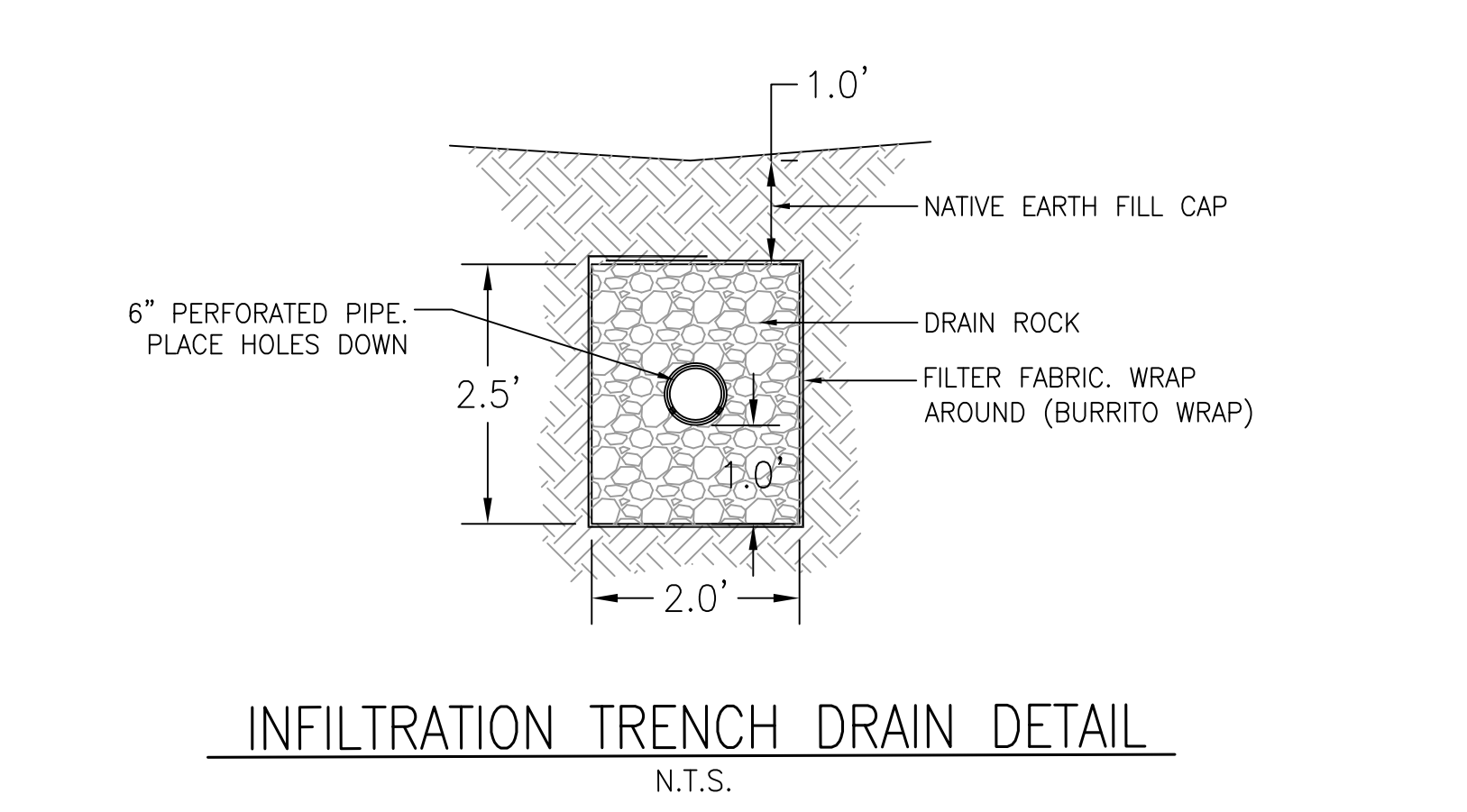
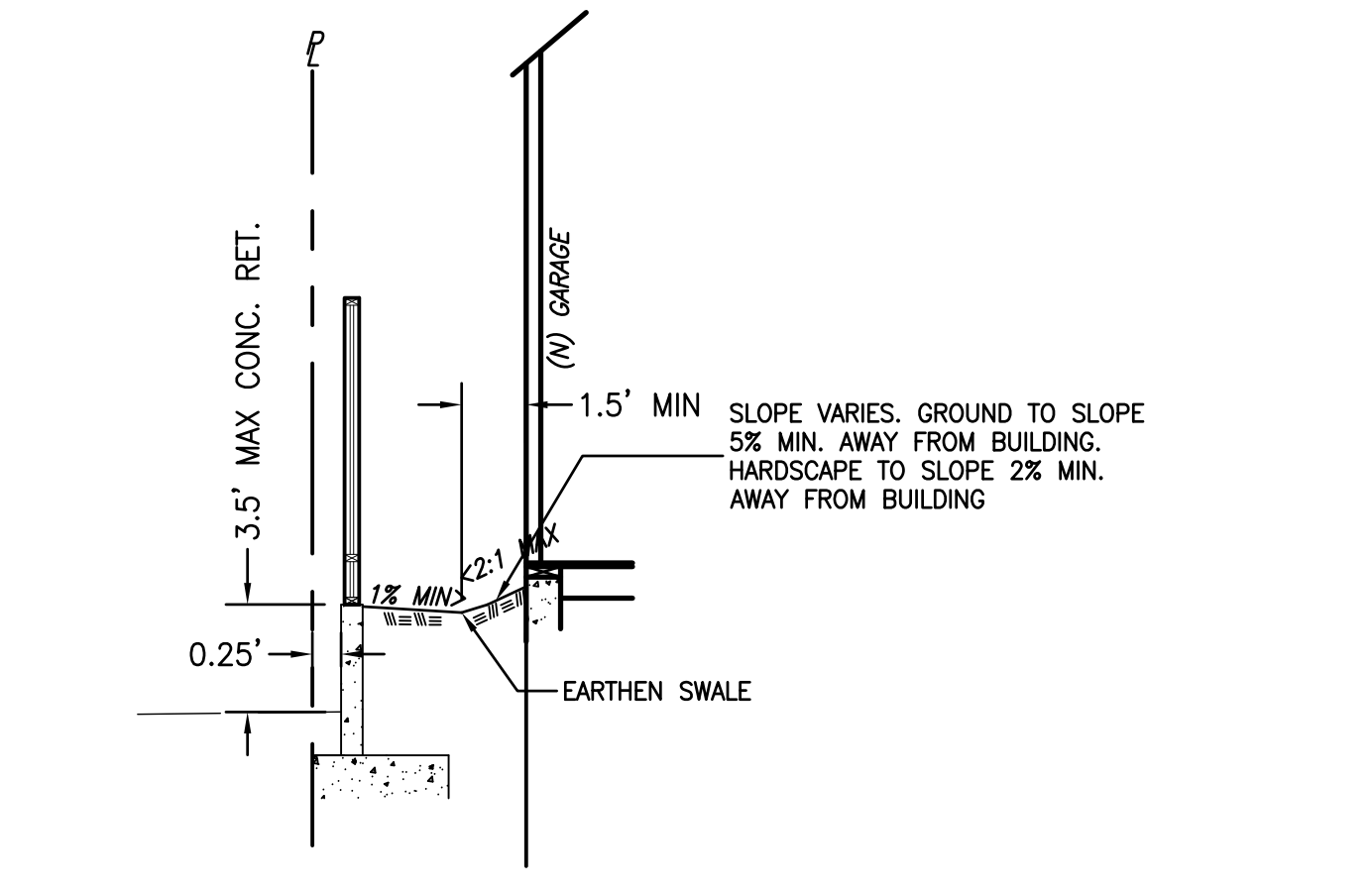

E RETAINING WALL AND GARAGE DETAIL

F INFILTRATION TRENCH DRAIN DETAIL

G EARTHEN SWALE DETAIL



SPLASH BLOCK IMAGE

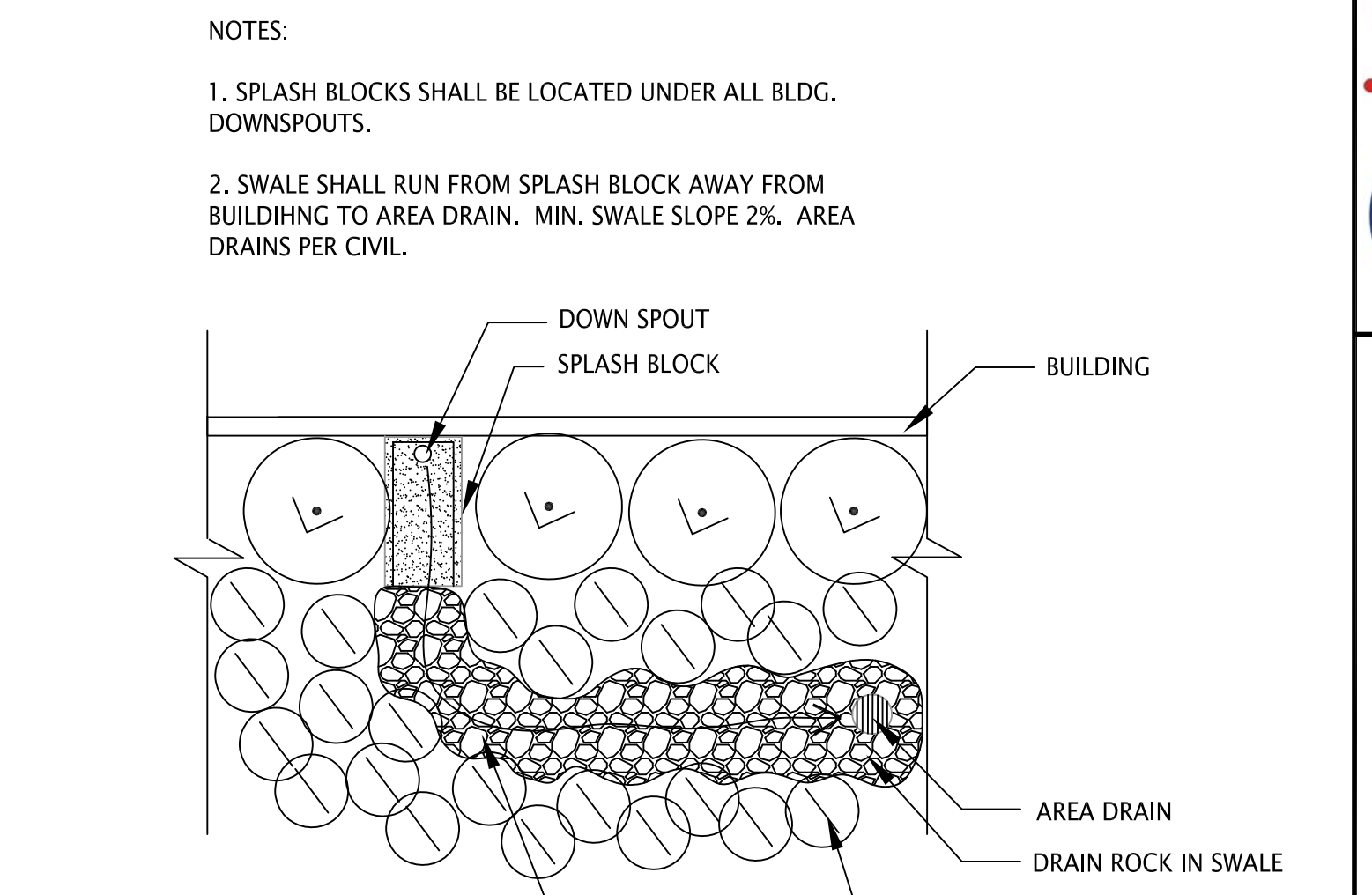

PLAN VIEW

H NOT USED

I SPLASH BLOCK DETAIL

NO.	REVISIONS	DATE	BY	CITY



Porfirio Oscar Osuna  
PORFIRIO OSCAR OSUNA  
RCE 70829 EXP. 6-30-19

**OSUNA**  
ENGINEERING INC.  
Planning | Surveying | Civil Engineering  
CONSULTING CIVIL ENGINEERS & LAND SURVEYORS  
TEL: (408) 772-4381  
117 BERNAL RD. STE. 70-336  
SAN JOSE, CA 95119  
Info@osunaengineering.com

GRADING & DRAINAGE PLAN  
CONSTRUCTION DETAILS  
163 DEL MONTE AVENUE  
LOS ALTOS, CALIFORNIA  
Project No.: 1386 | Design: J.O. | Check: J.O. | Date: 3/14/19

SHEET  
C2  
OF 3 SHEETS

CONTRACTOR AGREES THAT HE SHALL ASSUME SOLE AND COMPLETE RESPONSIBILITY FOR JOB SITE CONDITIONS DURING THE COURSE OF CONSTRUCTION OF THIS PROJECT, INCLUDING THE SAFETY OF ALL PERSONS AND PROPERTY AND SHALL BE LIMITED TO NORMAL WORKING HOURS. AND THAT THE CONTRACTOR SHALL BE RESPONSIBLE FOR THE PROTECTION OF ALL UTILITIES AND THE ENVIRONMENT FROM ANY AND ALL DAMAGE, INCLUDING THE PERFORMANCE OF WORK.

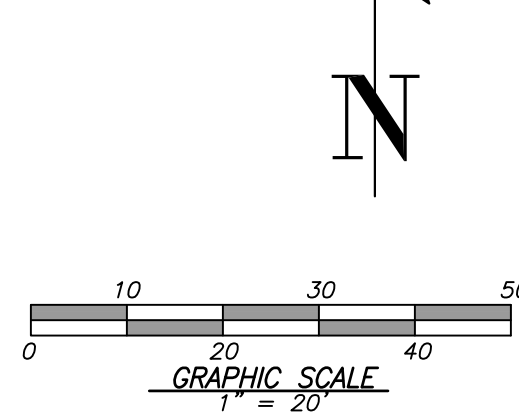
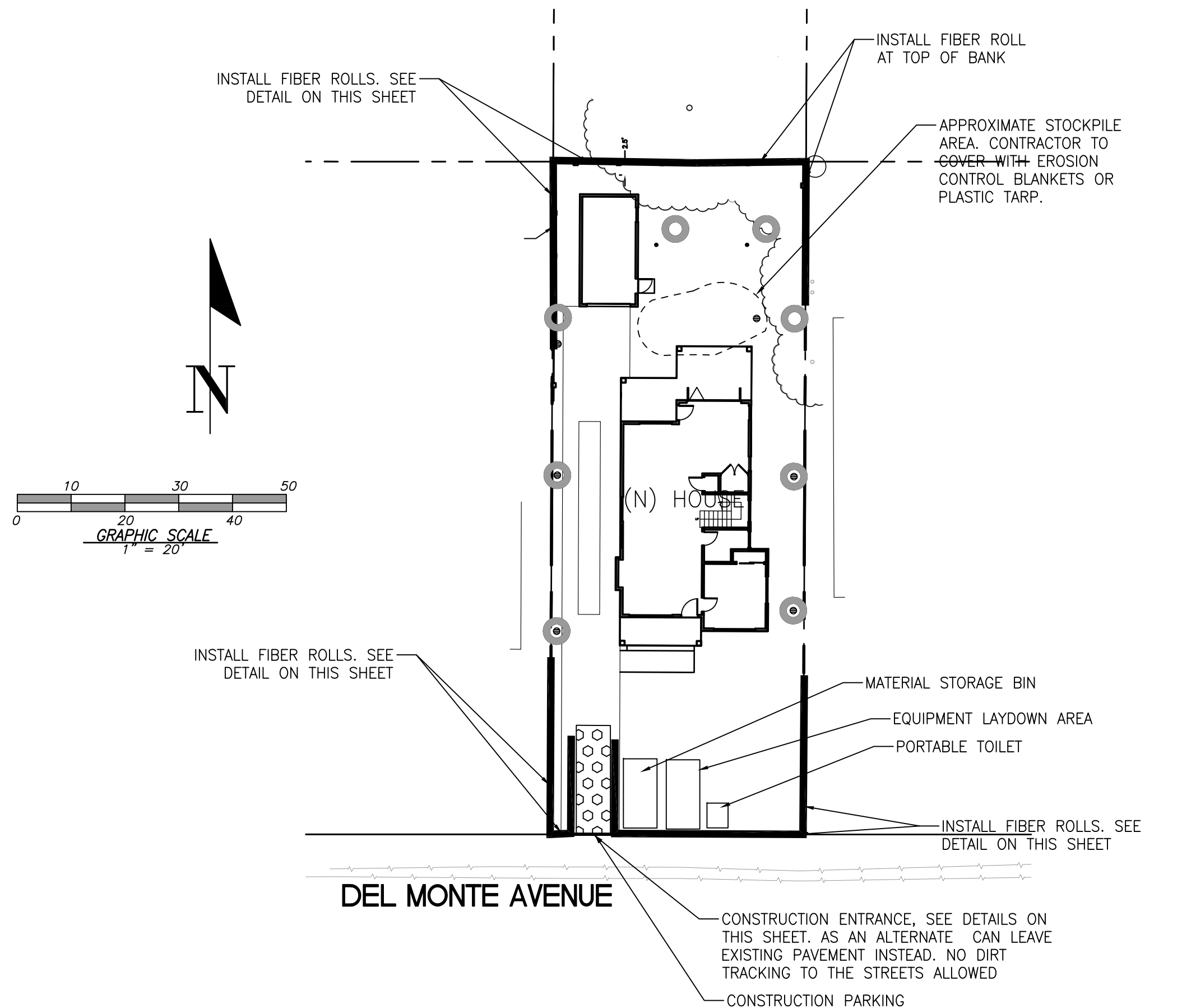

NOTES:  
 1. PROTECT ALL INLETS IN THE PUBLIC STREETS SURROUNDING THE SITE.  
 2. ALL ON-SITE LANDSCAPE AREA DRAINS TO BE CAPPED OR PROTECTED UNTIL LANDSCAPING IS FINISHED.

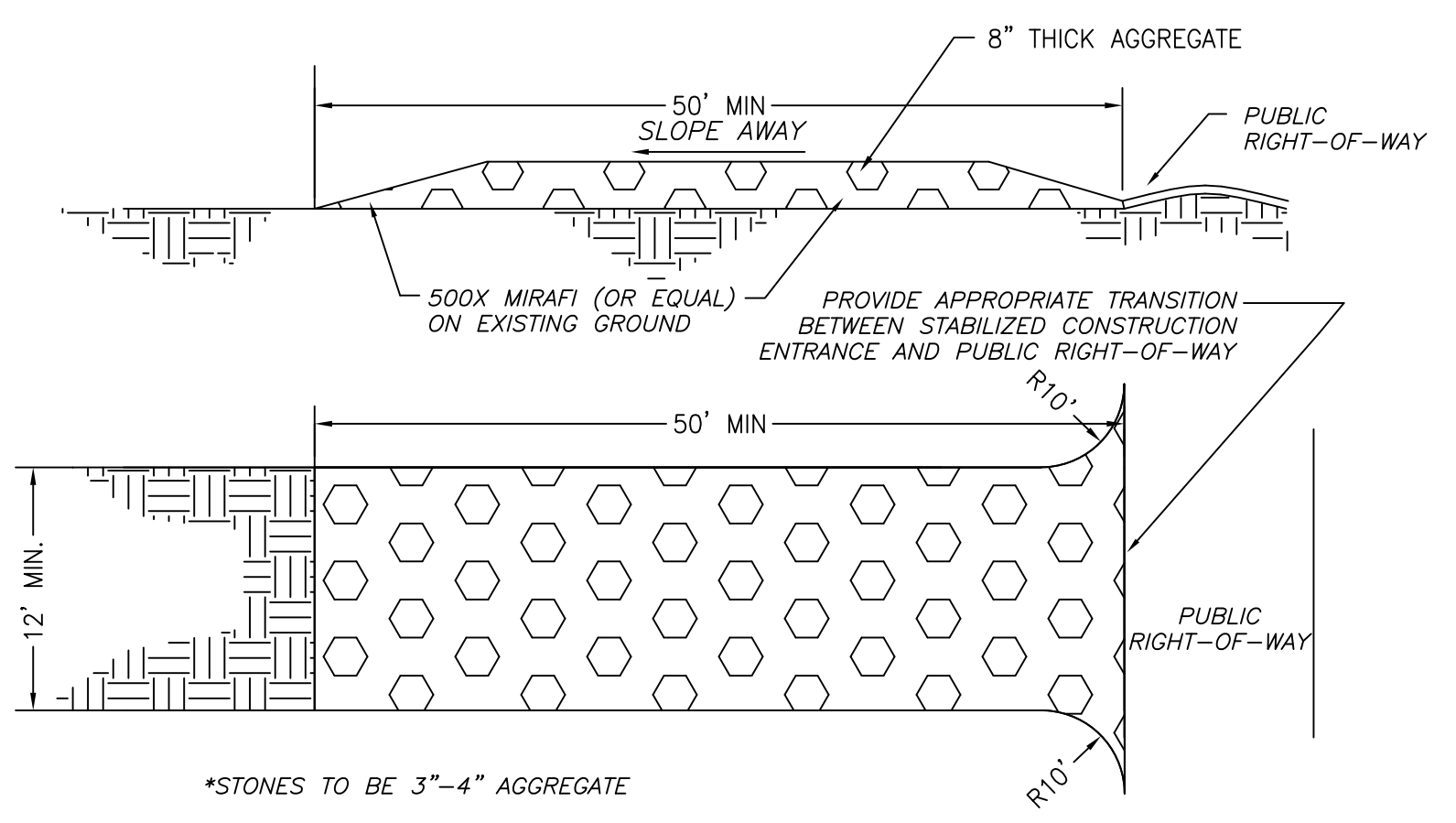

**MAINTENANCE:**  
 THE ENTRANCE SHALL BE MAINTAINED IN A CONDITION THAT WILL PREVENT TRACKING OR FLOWING SEDIMENT ONTO PUBLIC RIGHTS-OF-WAY. THIS MAY REQUIRE PERIODIC TOP DRESSING WITH ADDITIONAL STONE AS CONDITIONS DEMAND, AND REPAIR AND/OR CLEAN OUT ANY MEASURES USED TO TRAP SEDIMENT.  
 ALL SEDIMENT SPILLED, DROPPED, WASHED, OR TRACKED ONTO PUBLIC RIGHTS-OF-WAY SHALL BE REMOVED IMMEDIATELY.  
 WHEN NECESSARY, WHEELS SHALL BE CLEANED TO REMOVE SEDIMENT PRIOR TO ENTRANCE ONTO PUBLIC RIGHTS-OF-WAY. THIS SHALL BE DONE AT AN AREA STABILIZED WITH CRUSHED STONE, WHICH DRAINS INTO AN APPROVED SEDIMENT TRAP OR SEDIMENT BASIN.

**STABILIZED CONSTRUCTION ENTRANCE**  
N.T.S.

**LEGEND**

PROPOSED	DESCRIPTION
-----	SITE BOUNDARY
	STABILIZED CONSTRUCTION ENTRANCE 2"-3" ROCK (MIN)
	FIBER ROLL

**MAINTENANCE NOTES**  
 MAINTENANCE IS TO BE PERFORMED AS FOLLOWS:

- REPAIR DAMAGES CAUSED BY SOIL EROSION OR CONSTRUCTION AT THE END OF EACH WORKING DAY.
- SWALES SHALL BE INSPECTED PERIODICALLY AND MAINTAINED AS NEEDED.
- SEDIMENT TRAPS, BERMS, AND SWALES ARE TO BE INSPECTED AFTER EACH STORM AND REPAIRS MADE AS NEEDED.
- SEDIMENT SHALL BE REMOVED AND SEDIMENT TRAP RESTORED TO ITS ORIGINAL DIMENSIONS WHEN SEDIMENT HAS ACCUMULATED TO A DEPTH OF 1 FOOT.
- SEDIMENT REMOVED FROM TRAP SHALL BE DEPOSITED IN A SUITABLE AREA AND IN SUCH A MANNER THAT IT WILL NOT ERODE.
- RILLS AND GULLIES MUST BE REPAIRED.

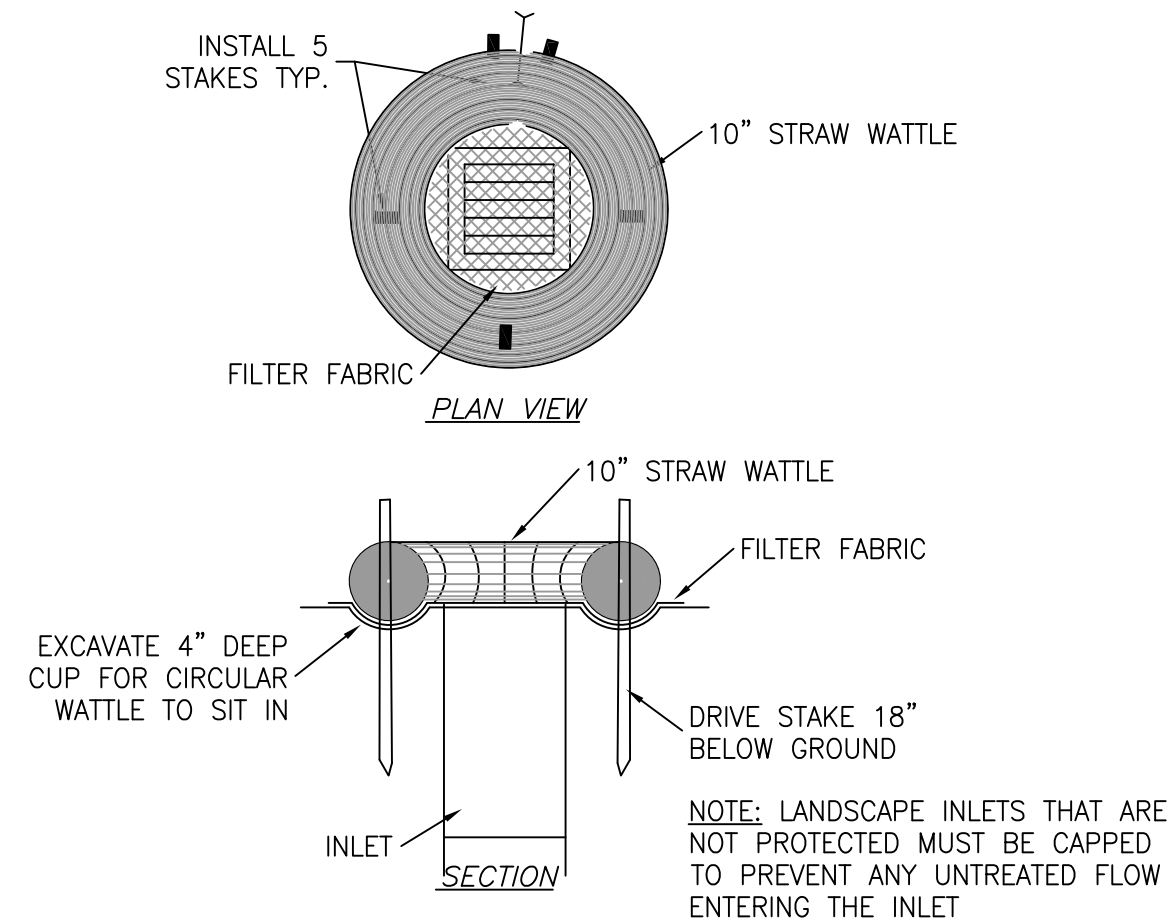

**ALTERNATE FIBER ROLL INLET PROTECTION**  
MAY BE USED IN LANDSCAPE AREA DRAINS  
N.T.S.

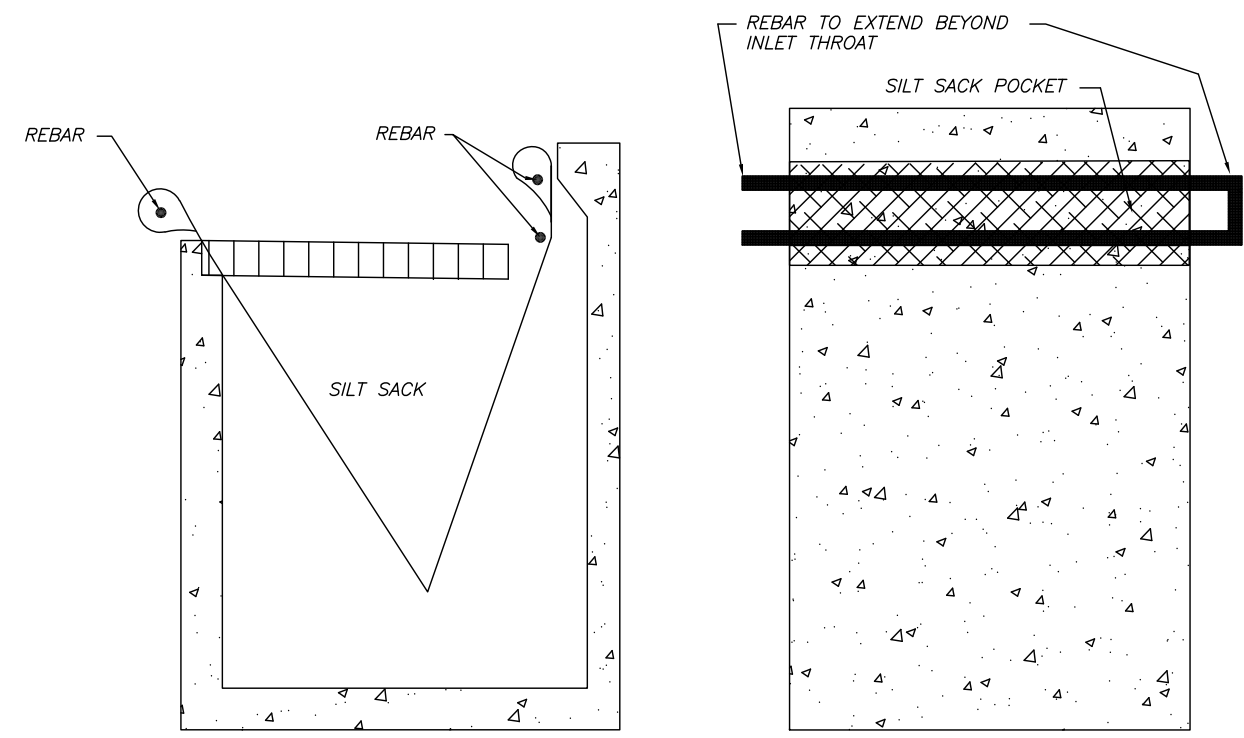

**CALIFORNIA MODIFIED SILT SACK**  
REED & GRAHAM, INC. (OR EQUAL)  
BEFORE & AFTER STREETS ARE PAVED  
N.T.S.

**EROSION & SEDIMENT CONTROL NOTES**

- NOT USED
- THE DEVELOPER IS RESPONSIBLE FOR ENSURING THAT ALL CONTRACTORS AND SUBCONTRACTORS ARE AWARE OF ALL STORM WATER QUALITY MEASURES AND IMPLEMENT SUCH MEASURES. FAILURE TO COMPLY WITH THE APPROVED CONSTRUCTION BEST MANAGEMENT PRACTICES WILL RESULT IN THE ISSUANCE OF CORRECTION NOTICES, CITATIONS, AND/OR STOP ORDERS.
- ANY VEHICLE OR EQUIPMENT WASHING/STEAM CLEANING MUST BE DONE AT AN APPROPRIATELY EQUIPPED FACILITY WHICH DRAINS TO THE SANITARY SEWER. OUTDOOR WASHING MUST BE MANAGED IN SUCH A WAY THAT THERE IS NO DISCHARGE OF SOAPS, SOLVENTS, CLEANING AGENTS OR OTHER POLLUTANTS TO THE STORM DRAINS. WASH WATER SHALL DISCHARGE TO THE SANITARY SEWER, SUBJECT TO REVIEW AND APPROVAL OF UNION SANITARY DISTRICT.
- THE CONTRACTOR SHALL BE RESPONSIBLE FOR LITTER CONTROL AND SWEEPING OF ALL PAVED SURFACES DURING CONSTRUCTION.
- THE FACILITIES SHOWN ON THIS PLAN ARE DESIGNED TO CONTROL EROSION AND SEDIMENT DURING THE RAINY SEASON, OCTOBER 1 TO APRIL 15. EROSION CONTROL MEASURES ARE TO BE FUNCTIONAL PRIOR TO OCTOBER 1ST OF ANY YEAR GRADING OPERATIONS HAVE LEFT AREAS UNPROTECTED FROM EROSION.
- ALL ON-SITE STORM DRAINS SHALL BE CLEANED IMMEDIATELY BEFORE THE START OF THE RAINY SEASON BEGINNING ON OCTOBER 1ST EACH YEAR, SUBJECT TO THE REVIEW OF THE BUILDING/ENGINEERING INSPECTOR.
- IF RAINY WEATHER BECOMES IMMINENT, GRADING OPERATIONS SHALL BE STOPPED AND EROSION CONTROL MEASURES SHALL BE IMPLEMENTED TO PROTECT DISTURBED AREAS.
- DURING THE RAINY SEASON, ALL PAVED AREAS SHALL BE KEPT CLEAR OF EARTH MATERIAL AND DEBRIS. THE SITE SHALL BE MAINTAINED SO AS TO MINIMIZE SEDIMENT LADEN RUNOFF TO ANY STORM DRAIN SYSTEM.
- CONSTRUCTION ENTRANCES SHALL CONSIST OF A MINIMUM 8" THICK LAYER OF 3"-4" FRACTURED STONE AGGREGATE UNLAI'D WITH GEOTEXTILE LINER FOR A MINIMUM DISTANCE OF 50 FEET, AND IS TO BE PROVIDED AT EACH VEHICLE ACCESS POINT TO EXISTING PAVED STREETS. THE DEPTH AND LENGTH OF AGGREGATE MAY NEED TO BE ADJUSTED IN THE FIELD TO ENSURE NO TRACKING OF SEDIMENT ONTO EXISTING PAVED STREETS. CONSTRUCTION ENTRANCES SHALL SLOPE AWAY FROM EXISTING PAVED STREETS.
- INLETS NOT USED IN CONJUNCTION WITH EROSION CONTROL MEASURES ARE TO BE BLOCKED UNLESS THE AREA DRAINED IS UNDISTURBED OR STABILIZED.
- BORROW AREAS AND TEMPORARY STOCKPILES SHALL BE PROTECTED WITH APPROPRIATE EROSION CONTROL MEASURES TO THE SATISFACTION OF THE CITY ENGINEER.
- NO STRAW BALES OR SILT FENCES SHALL BE USED AS EROSION CONTROL MEASURES. SILT FENCES MAY ONLY BE USED AS A PHYSICAL BARRIER TO PREVENT VEHICULAR AND PEDESTRIAN TRAFFIC FROM USING NON-APPROVED ACCESS POINTS (E.G. - ALONG RIGHT-OF-WAY).
- ALL DISTURBED AREAS INCLUDING FLAT PADS ARE TO BE TREATED WITH STRAW AND TACKIFIER AT A RATE OF 2 TONS PER ACRE APPROXIMATELY 3 INCHES THICK.

**SUPPLEMENTAL EROSION & SEDIMENT CONTROL NOTES**

- SEE STANDARD EROSION & SEDIMENT CONTROL NOTES ABOVE.
- THE FACILITIES SHOWN ON THIS PLAN ARE DESIGNED TO CONTROL EROSION AND SEDIMENT DURING THE RAINY SEASON, OCTOBER 1 TO APRIL 15. FACILITIES ARE TO BE OPERABLE PRIOR TO OCTOBER 1 OF ANY YEAR. GRADING OPERATIONS DURING THE RAINY SEASON WHICH LEAVE DENUDE'ED SLOPES SHALL BE PROTECTED WITH EROSION CONTROL MEASURES IMMEDIATELY FOLLOWING GRADING ON THE SLOPES.
- CONSTRUCTION ENTRANCES SHALL BE INSTALLED PRIOR TO COMMENCEMENT OF GRADING. ALL CONSTRUCTION TRAFFIC ENTERING ONTO THE PAVED ROADS MUST CROSS THE STABILIZED CONSTRUCTION ENTRANCE WAYS.
- CONTRACTOR SHALL MAINTAIN STABILIZED ENTRANCE AT EACH VEHICLE ACCESS POINT TO EXISTING PAVED STREETS. ANY MUD OR DEBRIS TRACKED ONTO PUBLIC STREETS SHALL BE REMOVED DAILY AND AS REQUIRED BY THE CITY.
- INLET PROTECTION SHALL BE INSTALLED AT OPEN INLETS TO PREVENT SEDIMENT FROM ENTERING THE STORM DRAIN SYSTEM. INLETS NOT USED IN CONJUNCTION WITH EROSION CONTROL ARE TO BE BLOCKED TO PREVENT ENTRY OF SEDIMENT.
- THIS EROSION AND SEDIMENT CONTROL PLAN MAY NOT COVER ALL THE SITUATIONS THAT MAY ARISE DURING CONSTRUCTION DUE TO UNANTICIPATED FIELD CONDITIONS. VARIATIONS AND ADDITIONS MAY BE MADE TO THIS PLAN IN THE FIELD. NOTIFY THE CITY REPRESENTATIVE OF ANY FIELD CHANGES.

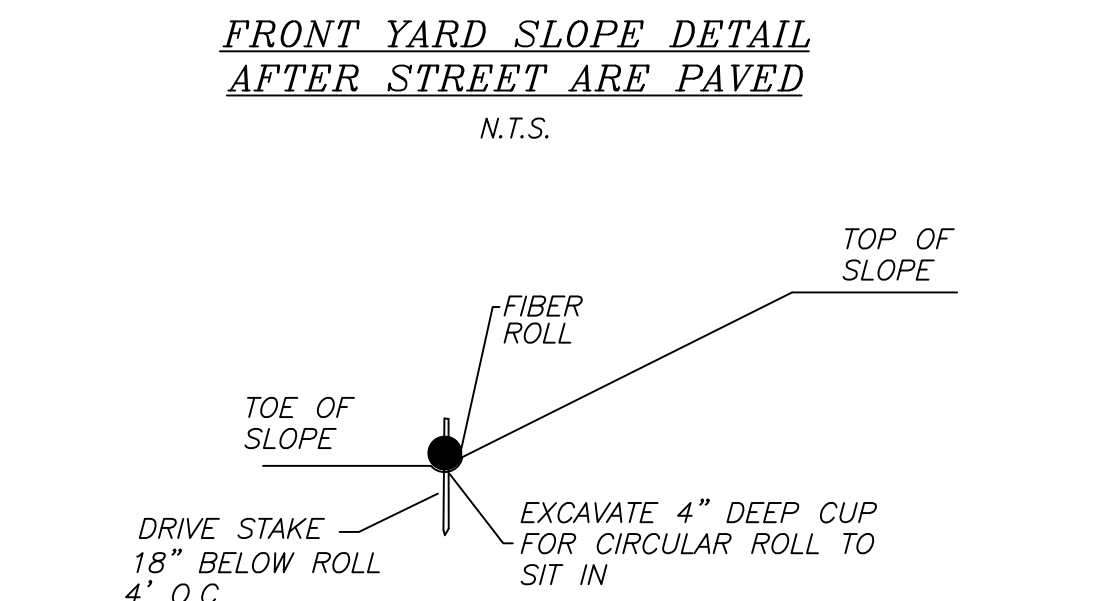
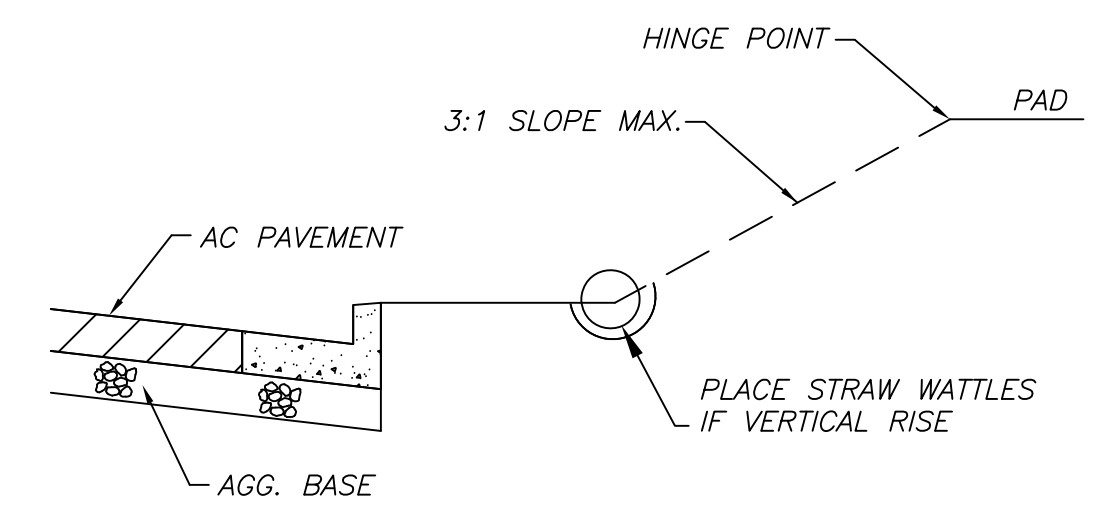

**FIBER ROLL INSTALLATION DETAIL**  
N.T.S.

				REVISIONS				
							PORFIRIO OSCAR OSUNA RCE 70829 EXP. 6-30-19	DATE CITY BY
<b>OSUNA ENGINEERING INC.</b> Planning Surveying Civil Engineering CONSULTING CIVIL ENGINEERS & LAND SURVEYORS 117 BERNAL RD. STE. 70-336 SAN JOSE, CA 95119 TEL: (408) 772-4381 info@osunaengineering.com								
<b>GRADING &amp; DRAINAGE PLAN</b> <b>EROSION CONTROL</b> <b>163 DEL MONTE AVENUE</b> LOS ALTOS, CALIFORNIA Project No.: 1386   Designed: J.O   Checked: J.O   Date: 3/14/19								
SHEET <b>C3</b> OF 3 SHEETS								



2-STORY HOUSE



2-STORY HOUSE

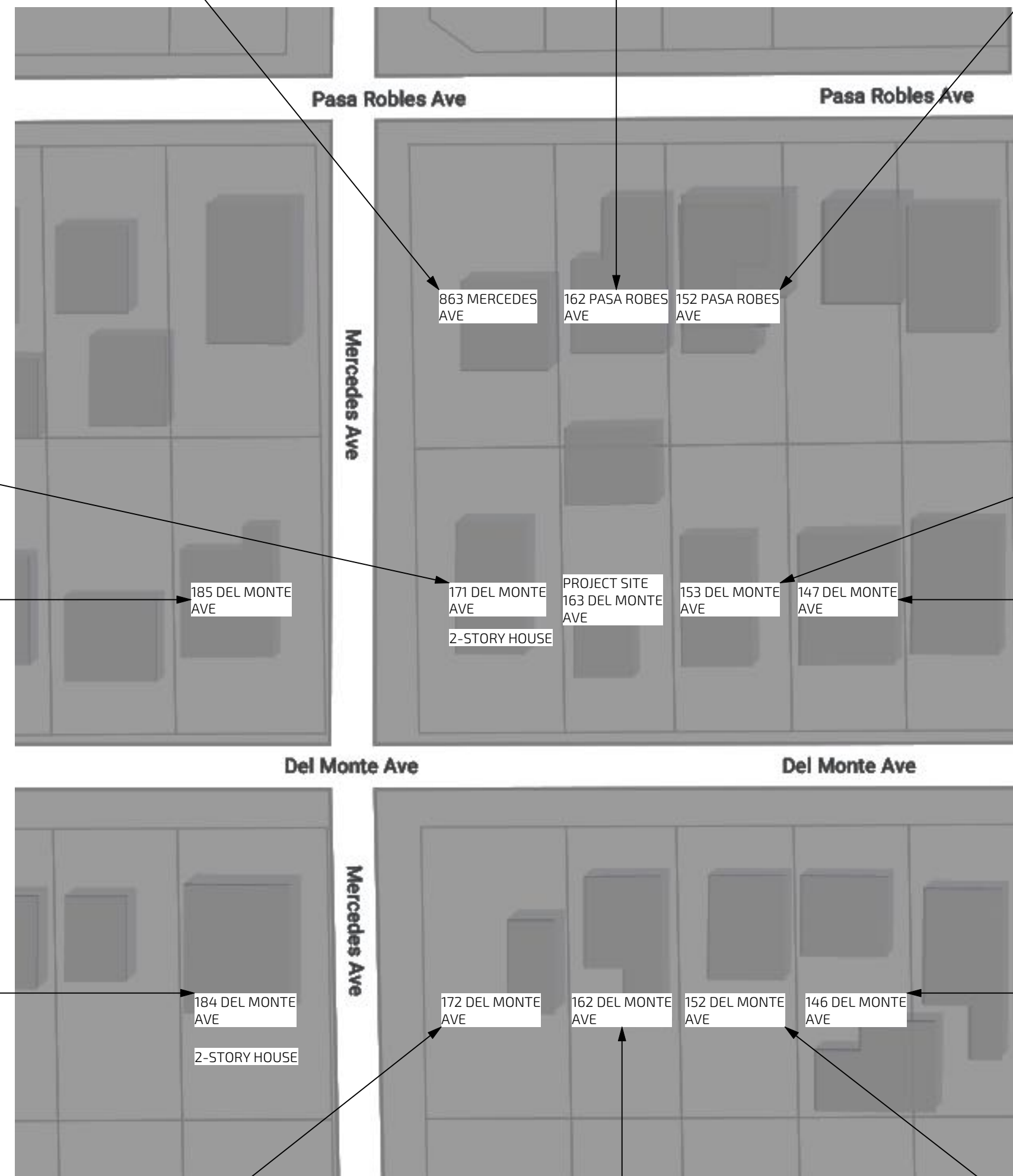

kc

kylechan  
ARCHITECT  
5205 PROSPECT ROAD  
SUITE 135-120,  
SAN JOSE, CA 95129  
510-396-9731  
www.kylechan.com  
kyle@kylechan.com

PLANNING REVISED SET  
4.19.2019

Sheet Revisions:



WU RESIDENCE  
NEW RESIDENCE  
163 DEL MONTE AVENUE  
LOS ALTOS, CA 94022

PLANNING SET  
NOT FOR CONSTRUCTION

STREETSCAPE  
DIAGRAM

A0.2

PROJECT NUMBER: 1619  
163 DEL MONTE AVE

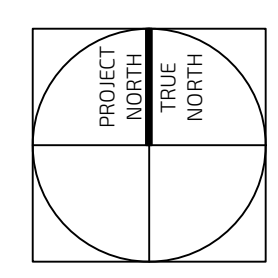
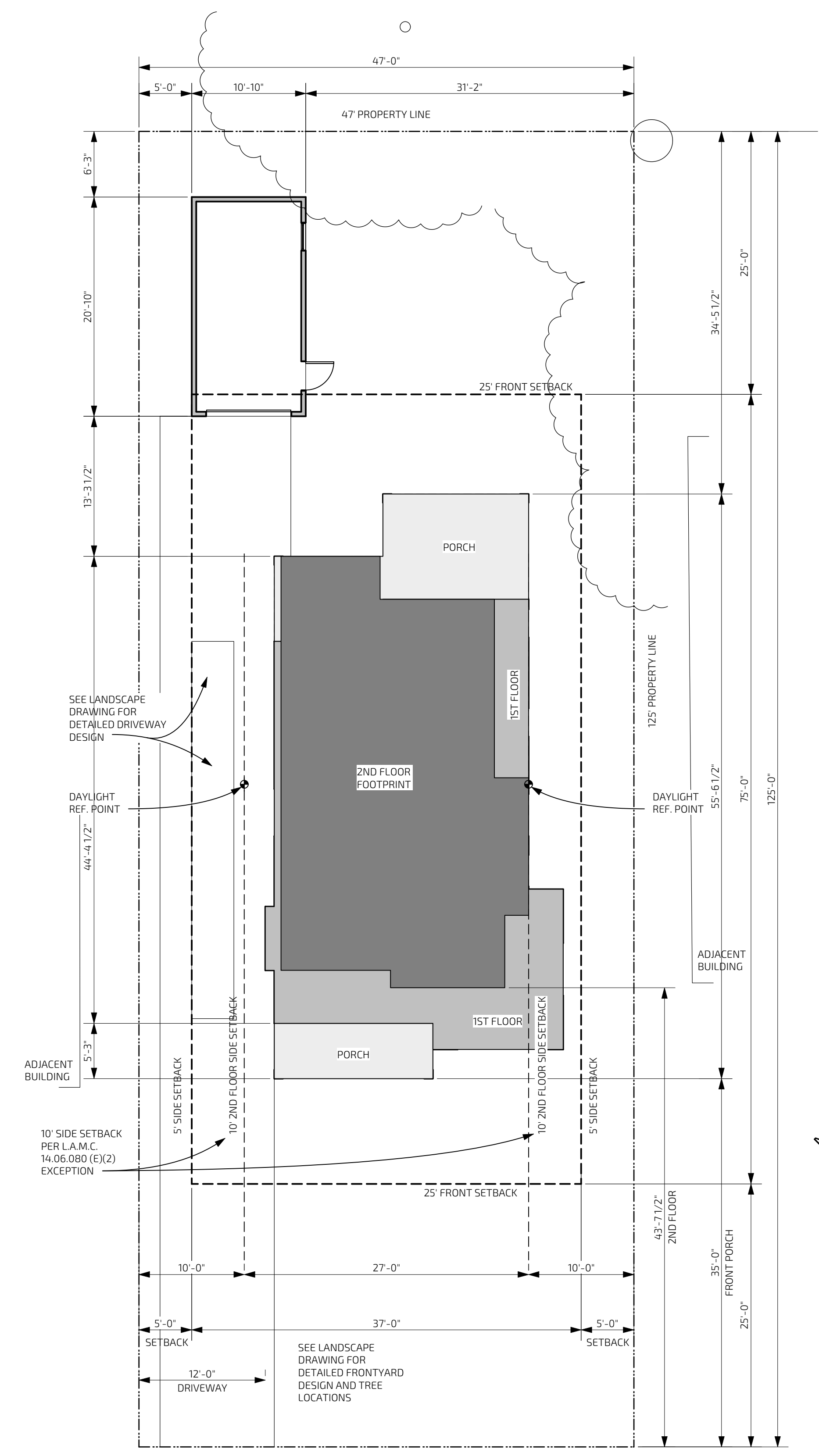

**SITE PLAN 1**  
SCALE 1/8" = 1'-0"

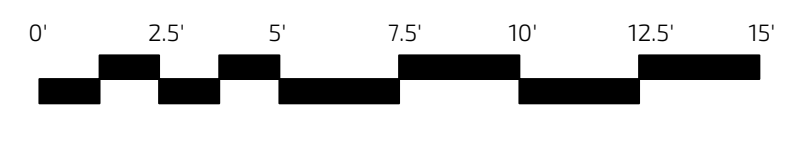
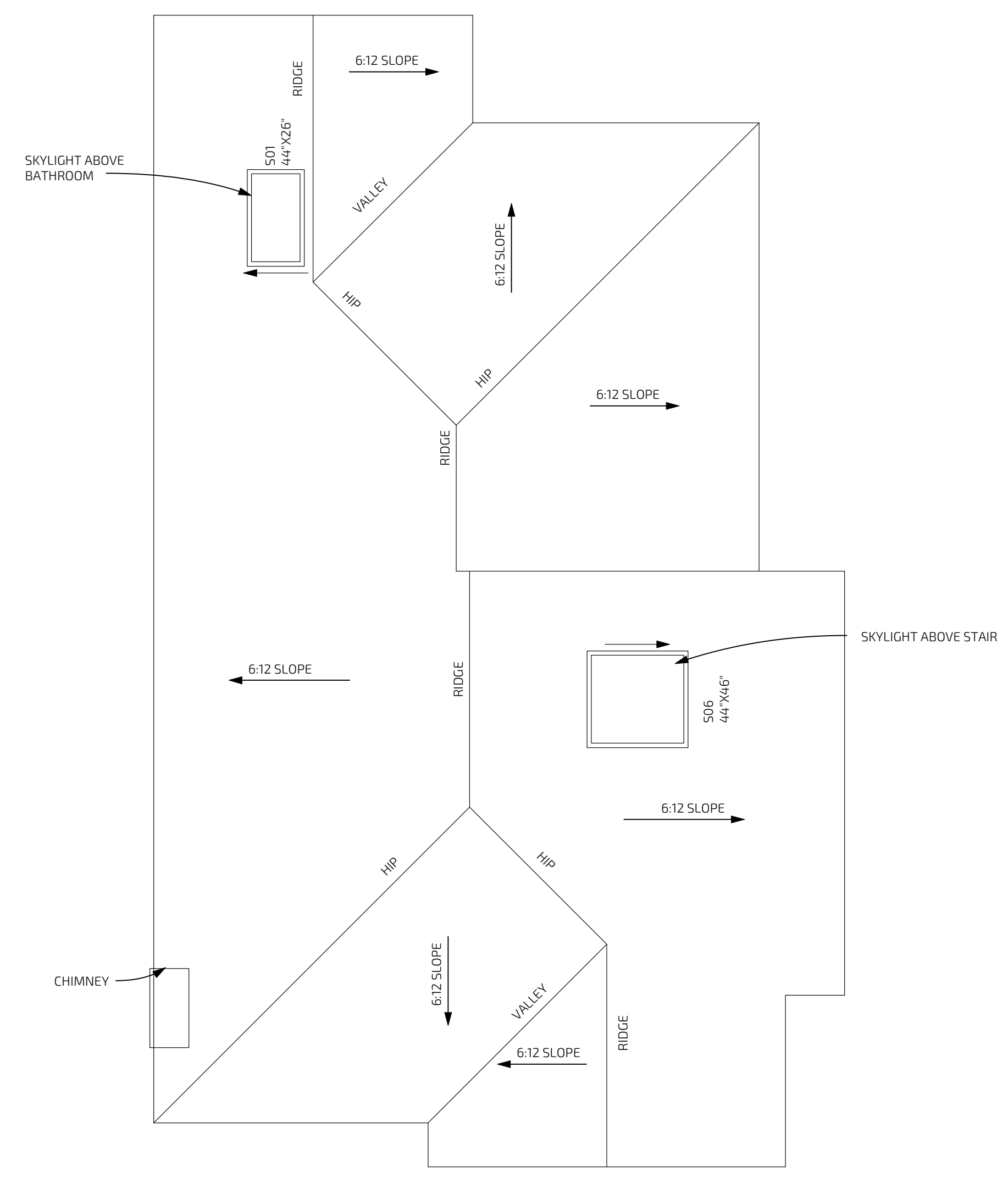

**ROOF PLAN 2**  
SCALE 1/4" = 1'-0"

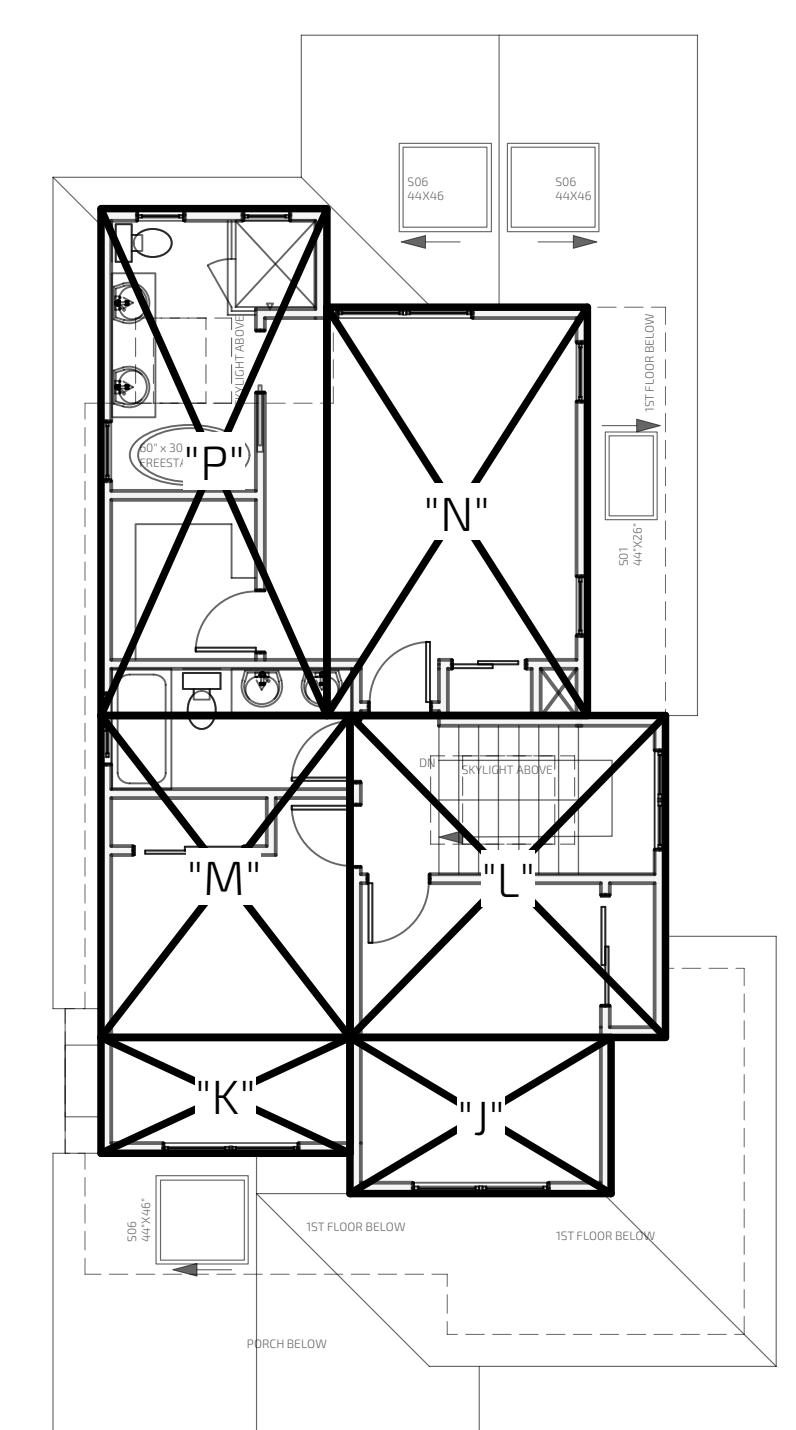

**2ND FLOOR PLAN**

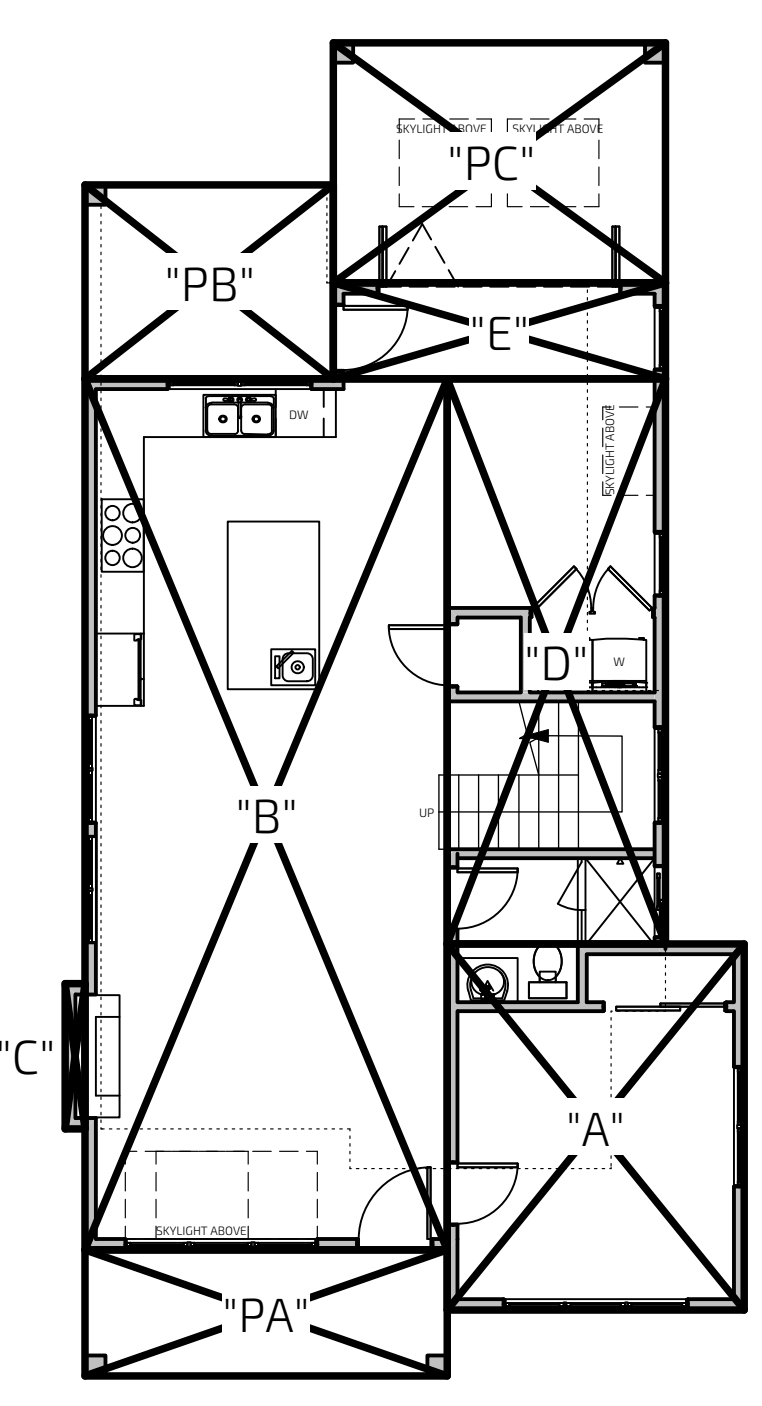
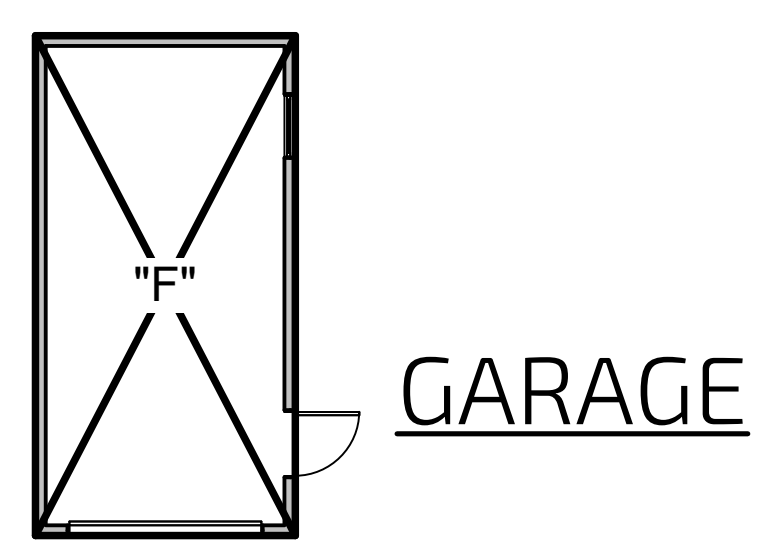

**1ST FLOOR PLAN**

**AREA CALCULATION 3**  
SCALE 1/8" = 1'-0"

FLOOR AREA CALCULATION		
<b>1ST FLOOR</b>		
LABEL	DIMENSIONS	AREA
A	12'4" x 15'3"	188.7 SF
B	15'1" x 36'3.5"	547.4 SF
C	10" x 6'5"	5 SF
D	9'1" x 23'6.5"	213.8 SF
E	13'10" x 4'	55.3 SF
<b>GARAGE</b>		
F	10'10" x 20'10"	225.7 SF
<b>2ND FLOOR</b>		
J	10'10.5" x 6'6"	70.7 SF
K	10'4.75" x 4'10"	50.2 SF
L	13'1.5" x 13'5"	176.1 SF
M	10'4.75" x 13'5"	139.5 SF
N	10'10.25" x 17'	184.5 SF
P	9'6" x 21'1.5"	198.9 SF
<b>CONDITIONED AREA</b>		
1ST FLOOR (A-E)		1010.2 SF
2ND FLOOR (J-P)		819.9 SF
GARAGE (F)		225.7
<b>TOTAL</b>		<b>2055.8 SF</b>
<b>FLOOR AREA RATIO</b>		
LOT SIZE		5,875 SF
F.A.R.		35%
<b>PORCH AREA</b>		
PA	15'1" x 5'3"	79.2 SF
PB	10'4" x 8'1"	83.5 SF
PC	13'10" x 10'	138.3 SF
<b>TOTAL</b>		<b>301 SF</b>
<b>LOT COVERAGE</b>		
(1ST FLOOR+GARAGE+PORCHES)		
1010.2 + 225.7 + 301		1536.9
LOT COVERAGE %		26.2%

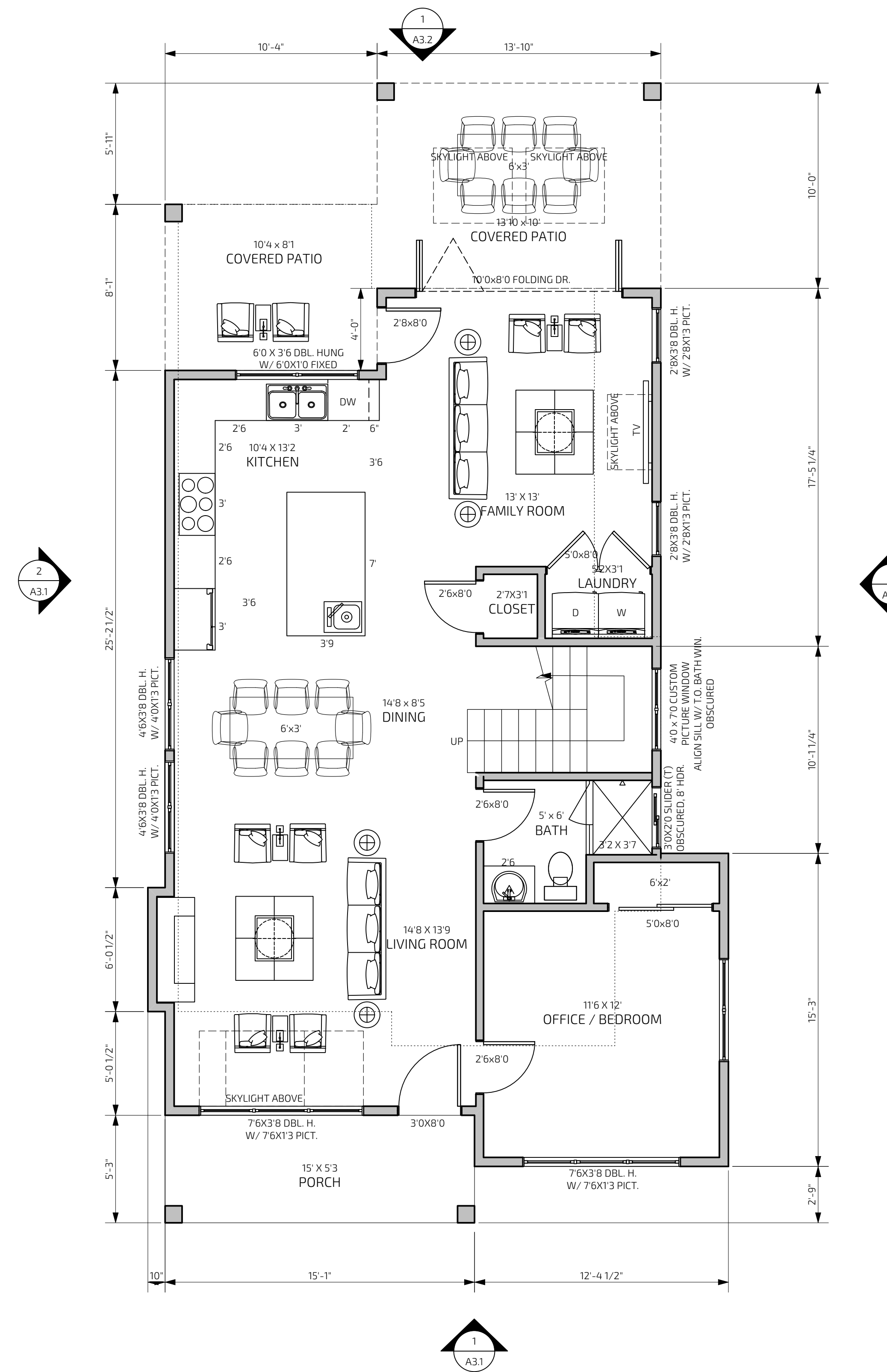
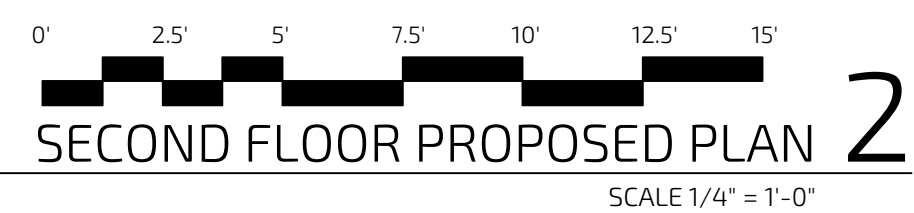
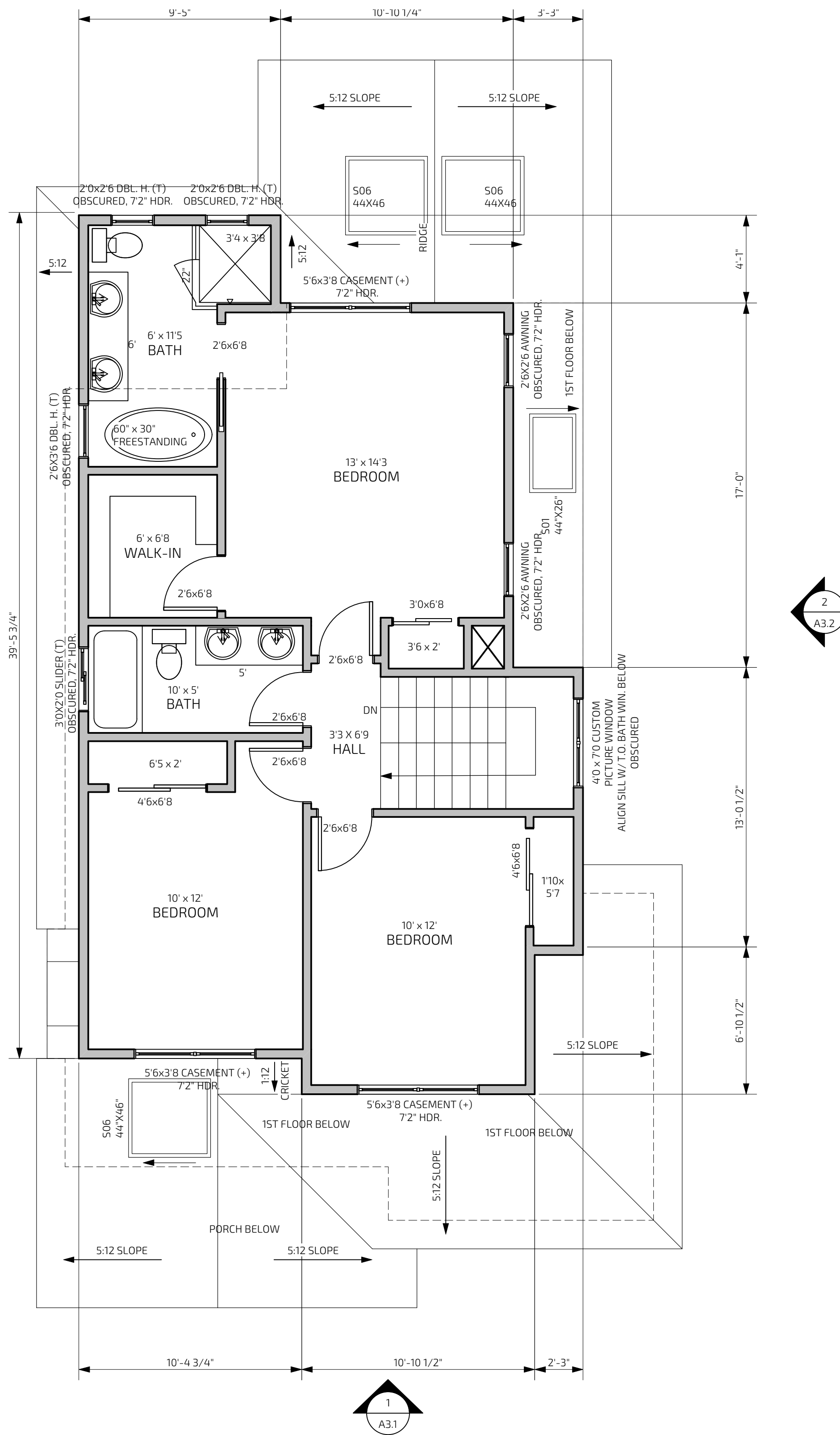



SYMBOL	MATERIAL	COLOR
R1	ASPHALT ROOF SHINGLES CERTAINTED PRESIDENTIAL SERIES WEATHERWOOD OR SIM.	BROWN
R2	CRICKET ROOFING: BUILT-UP ROOF BY CERTAINTED BUR OR SIM. COLOR TO MATCH ROOF SHINGLE	BROWN
S1	CLAD STONE VENEER PANEL BY ELDORADO STONE: MESA VERDE	TAN
G1	GUTTER: PAINTED GSM	WHITE
CS1	PAINTED CEMENT BASED SHINGLE SIDING BY JAMES HARDIE: HARDIESHINGLE SIDING	P1
P1	EXTERIOR PAINT TO MATCH BEN MOORE IRON MOUNTAIN	IRON MOUNTAIN
CS2	PAINTED CEMENT BASED MILL LAP SIDING BY JAMES HARDIE: ARTISAN ARTISAN SMOOTH LAP SIDING	P2
P2	EXTERIOR PAINT TO MATCH JAMES HARDIE TIMBER BARK	TIMBER BARK
CS3	PAINTED CEMENT BASED VERTICAL SMOOTH SIDING BY JAMES HARDIE: HARDIE ARTISAN VERTICAL SIDING	P2
P3	TRIM PAINT - BENJAMIN MOORE CLOUD WHITE	WHITE

(\*) ALL COLORS AND TEXTURE/TRIMS ARE REPRESENTATIVE SAMPLES ONLY.  
PENDING VERIFICATION OF ACTUAL MATERIAL SUPPLIERS AND  
MANUFACTURERS FOR THIS PROJECT.

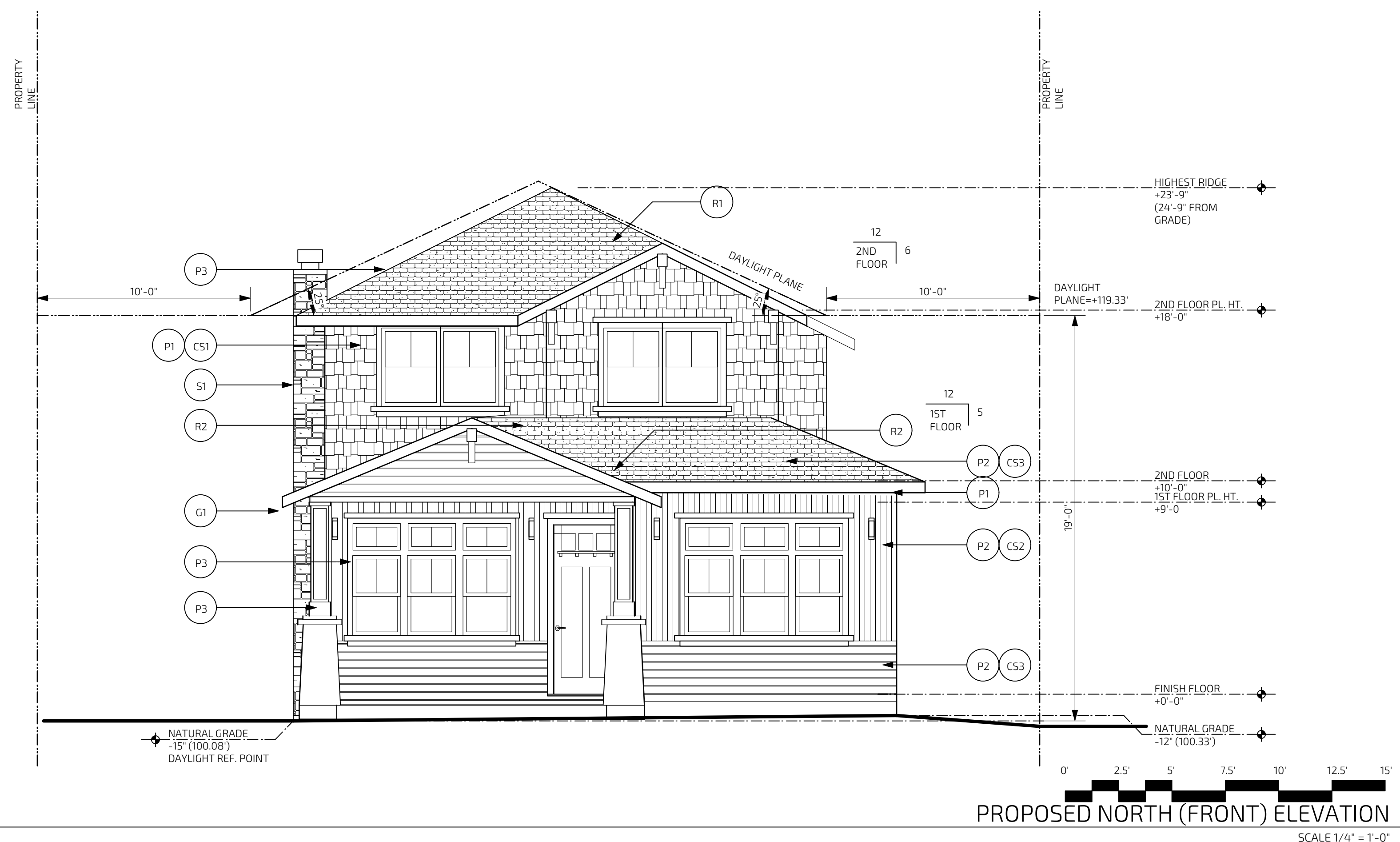
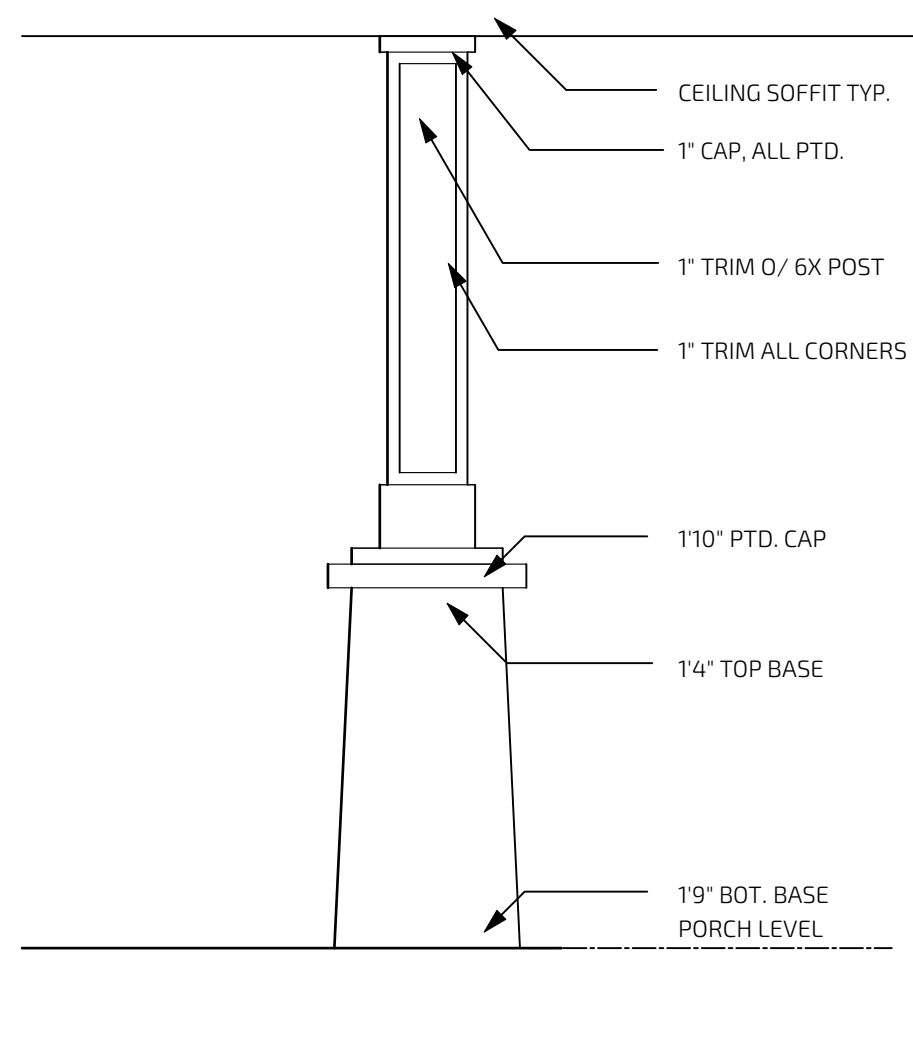
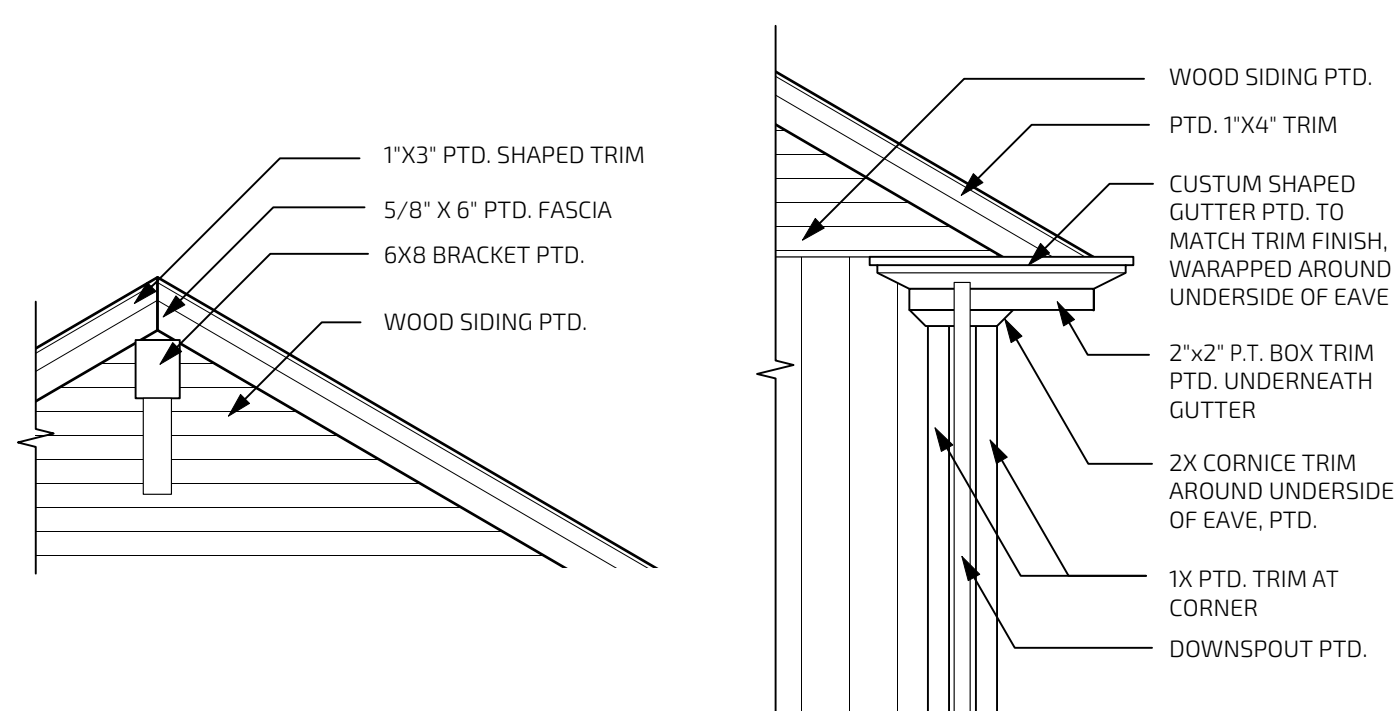

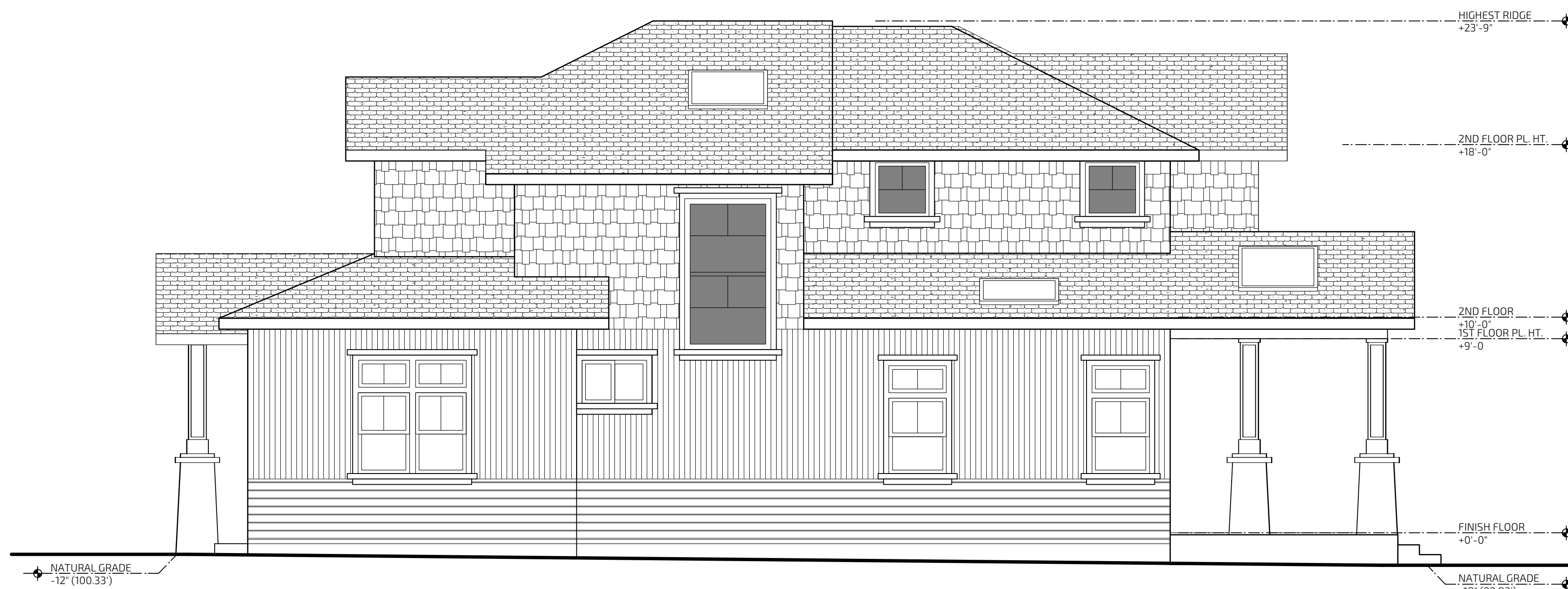

0' 2.5' 5' 7.5' 10' 12.5' 15'  
PROPOSED WEST (RIGHT) ELEVATION 2  
SCALE 1/4" = 1'-0"

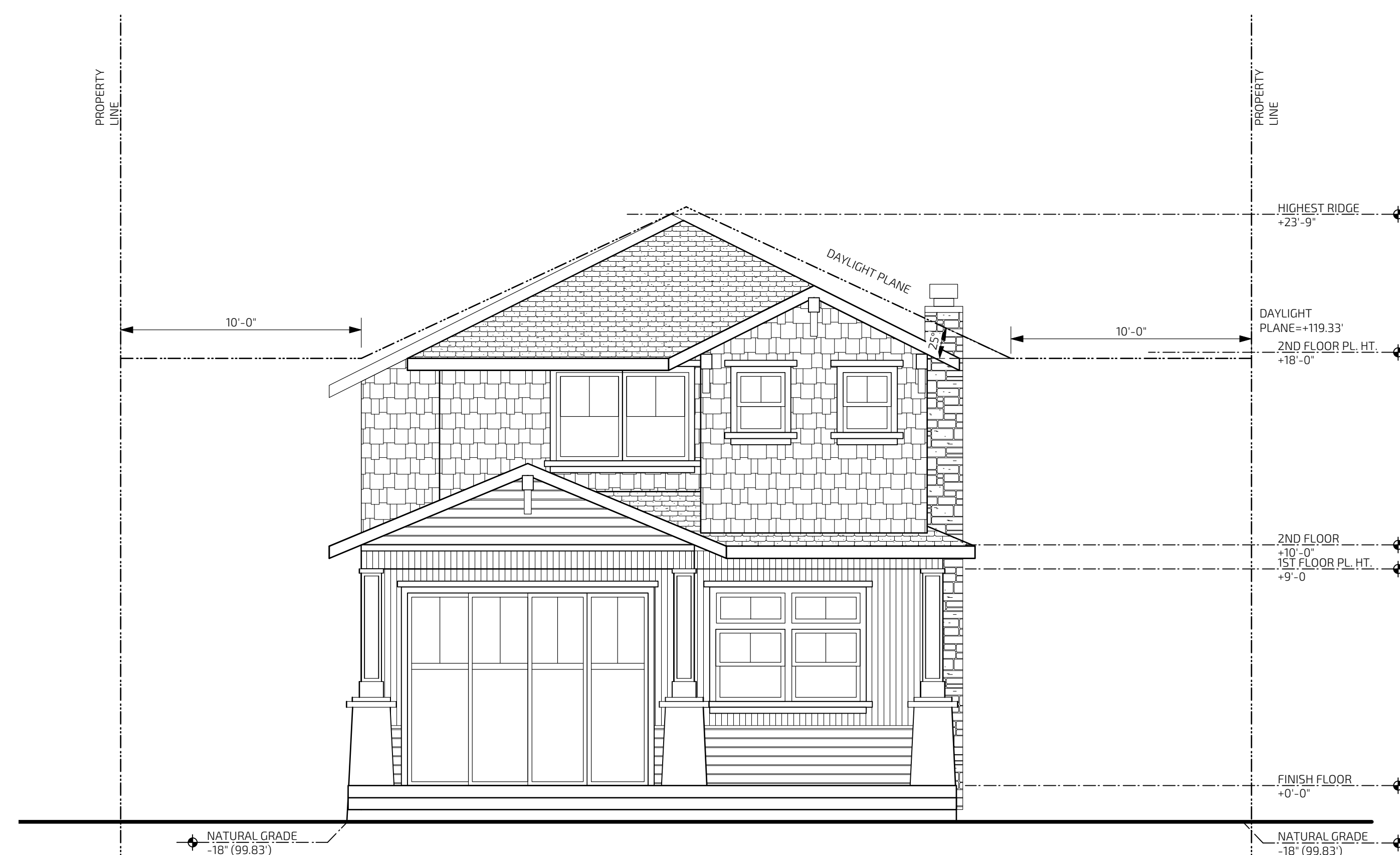

0' 2.5' 5' 7.5' 10' 12.5' 15'  
PROPOSED SOUTH (BACK) ELEVATION 1  
SCALE 1/4" = 1'-0"

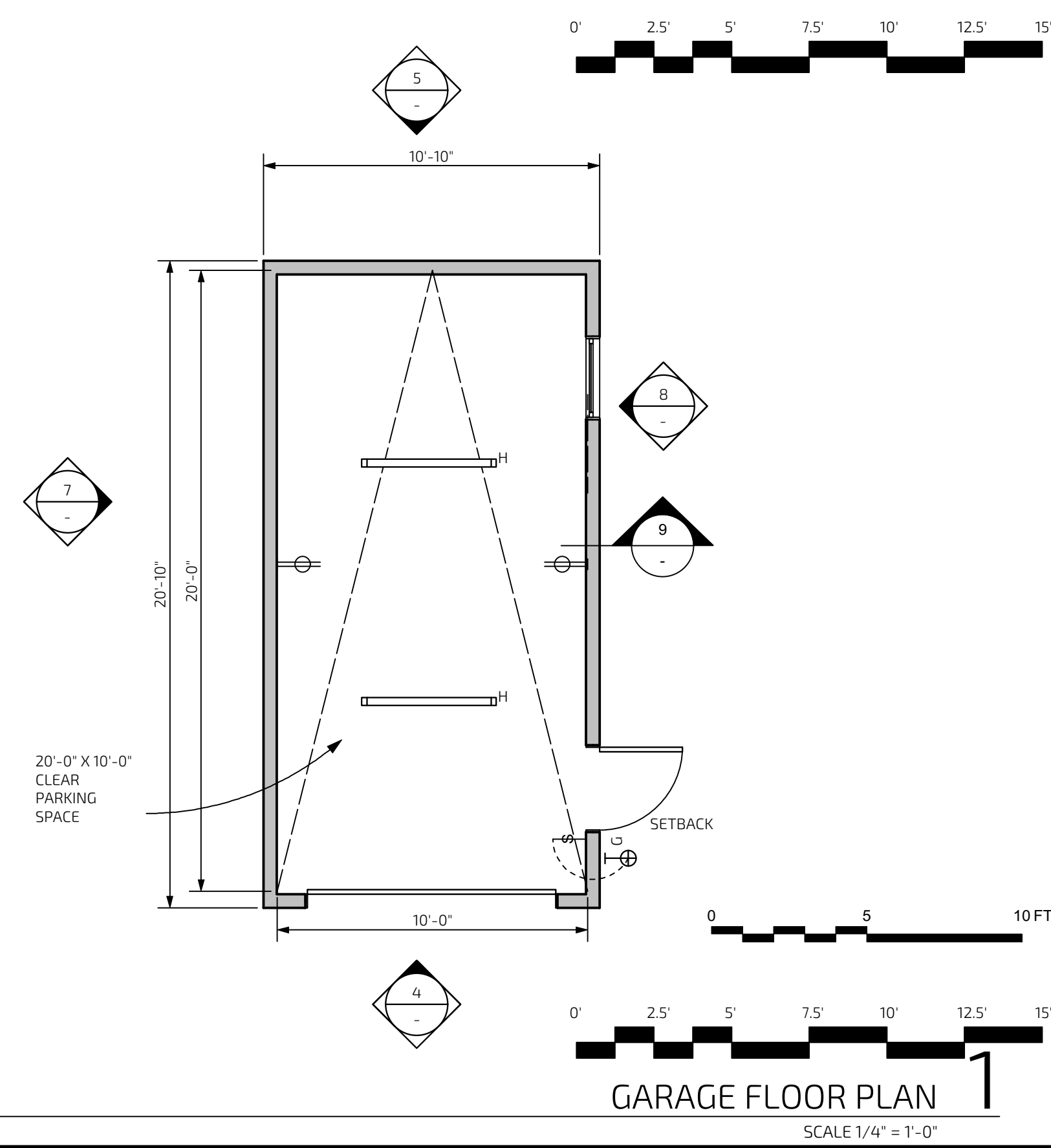
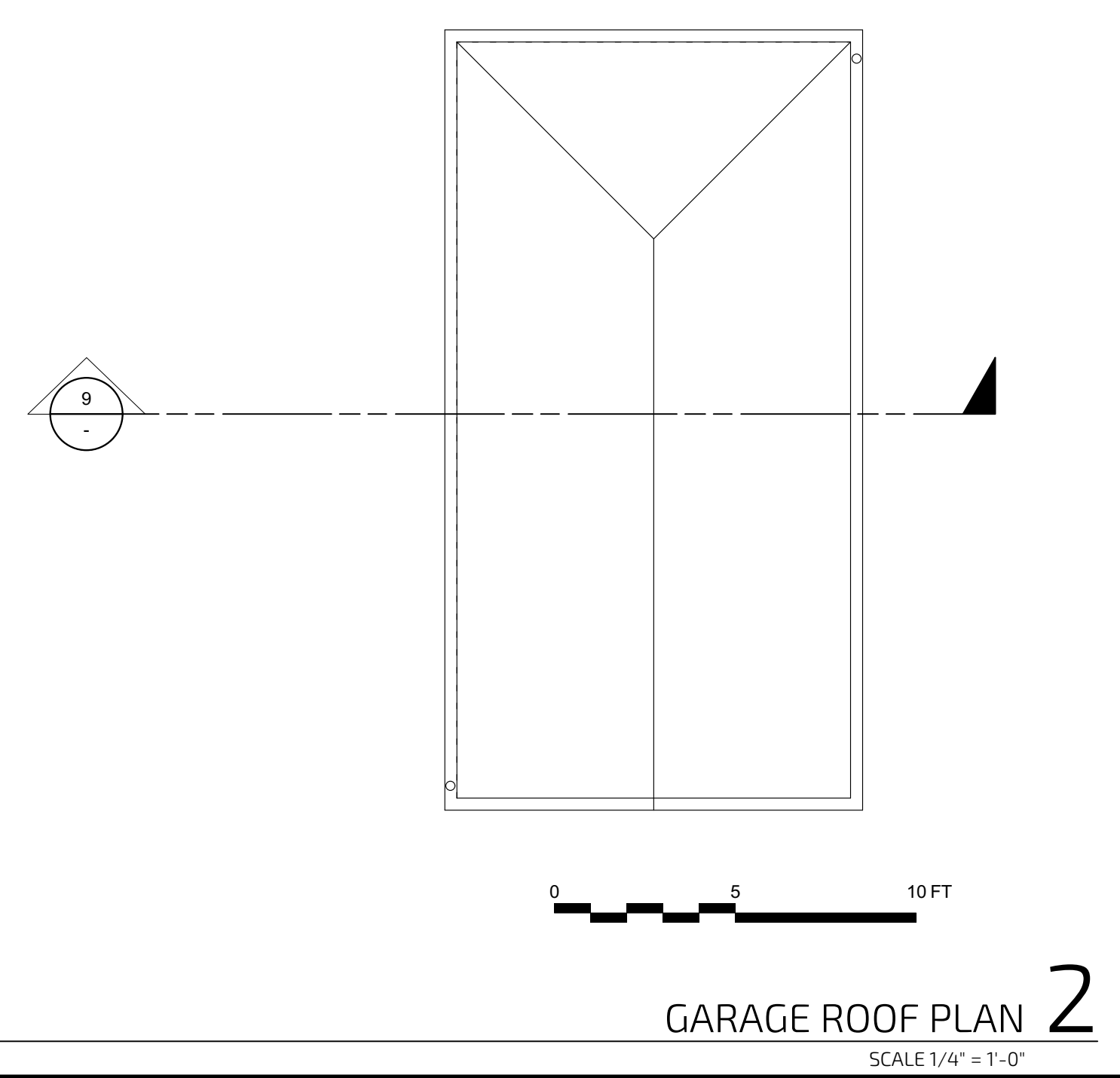
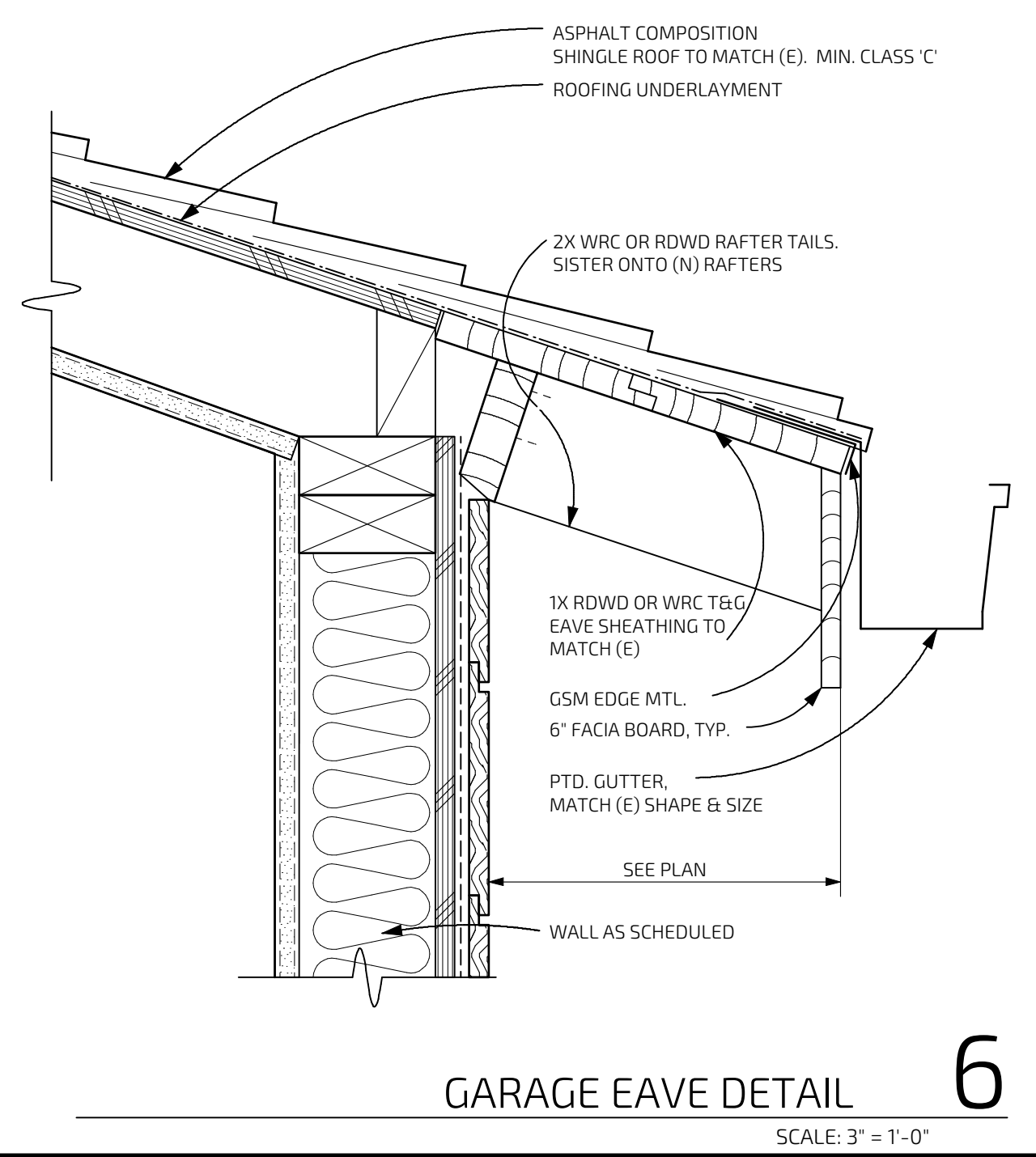
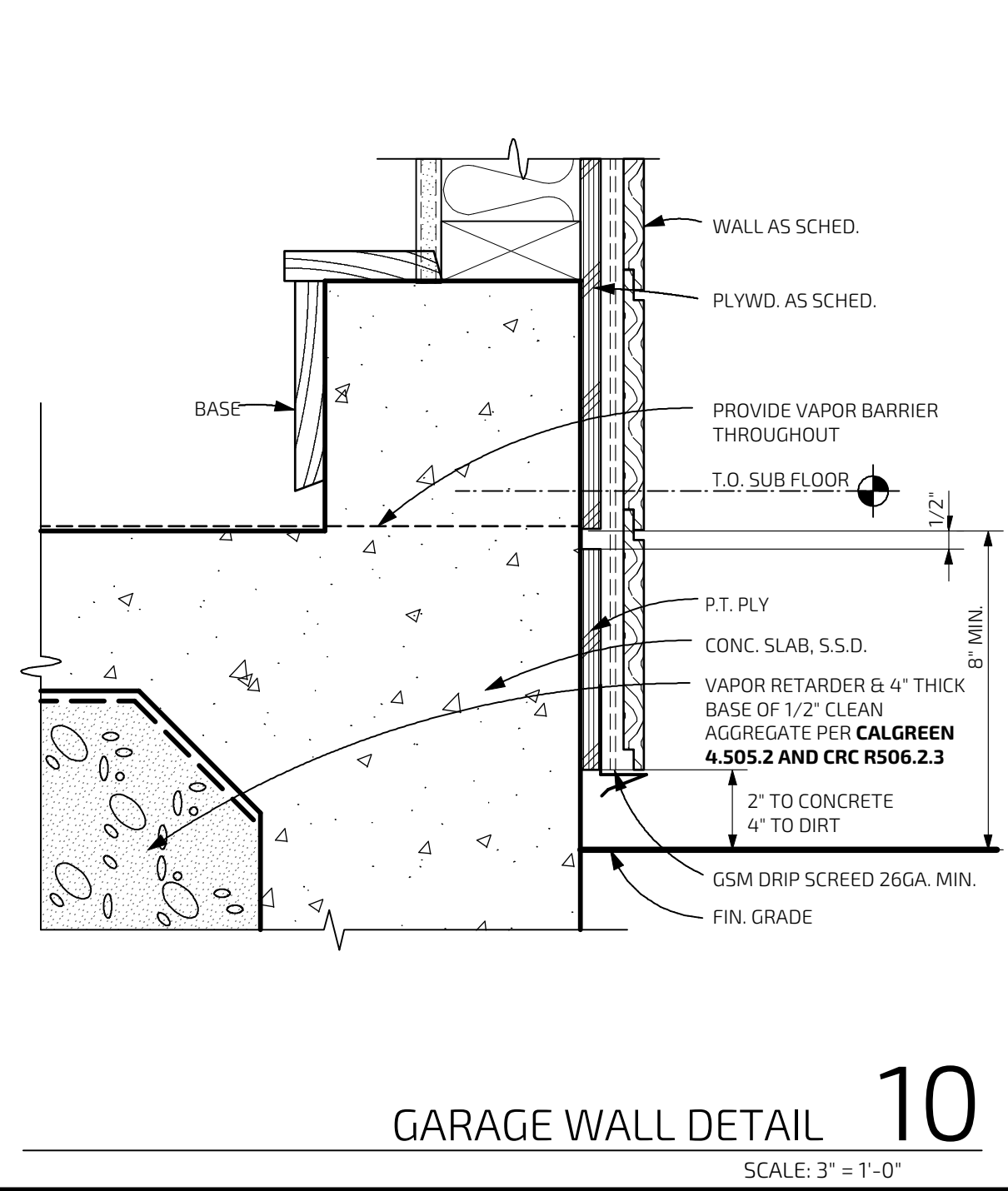
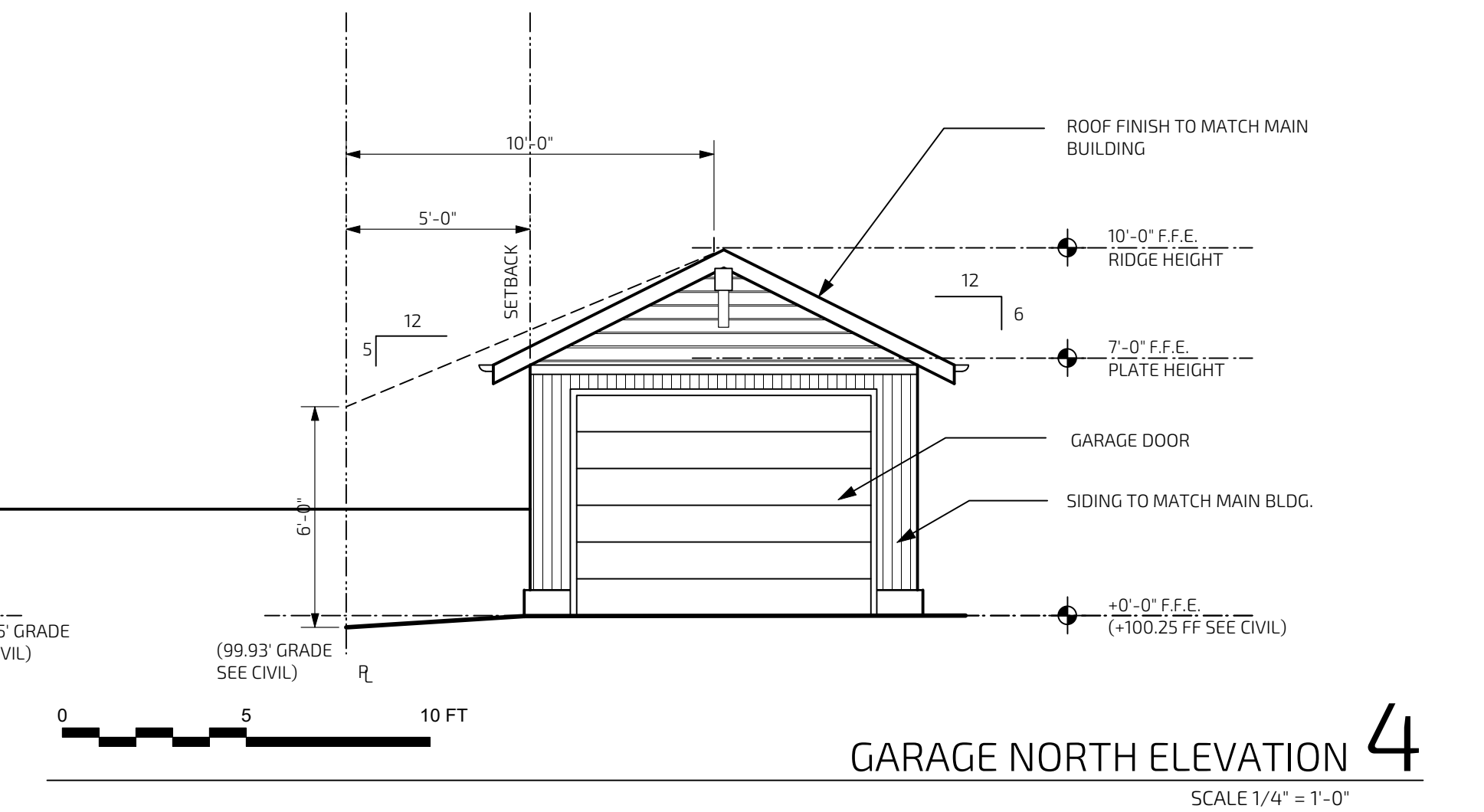
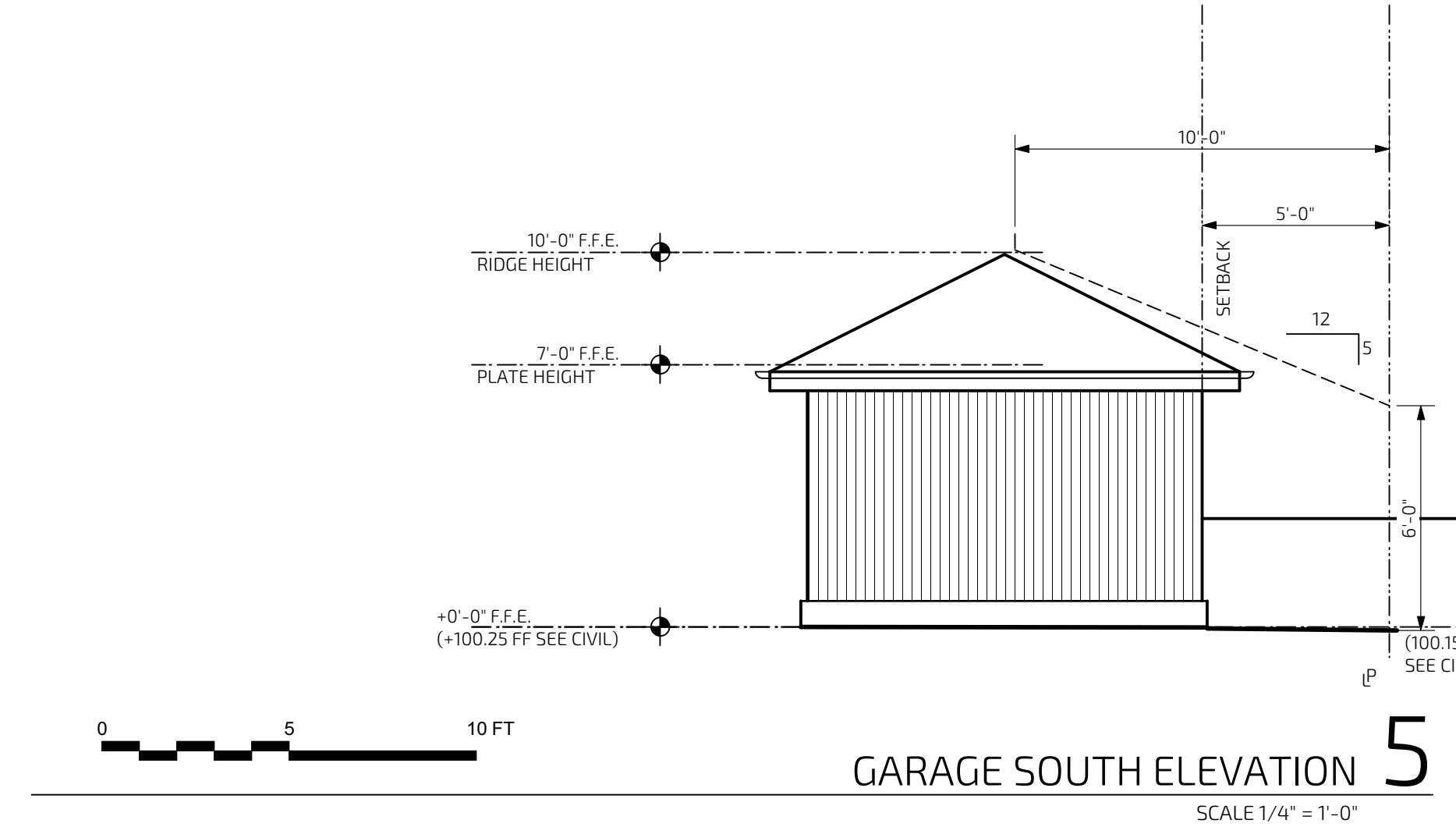
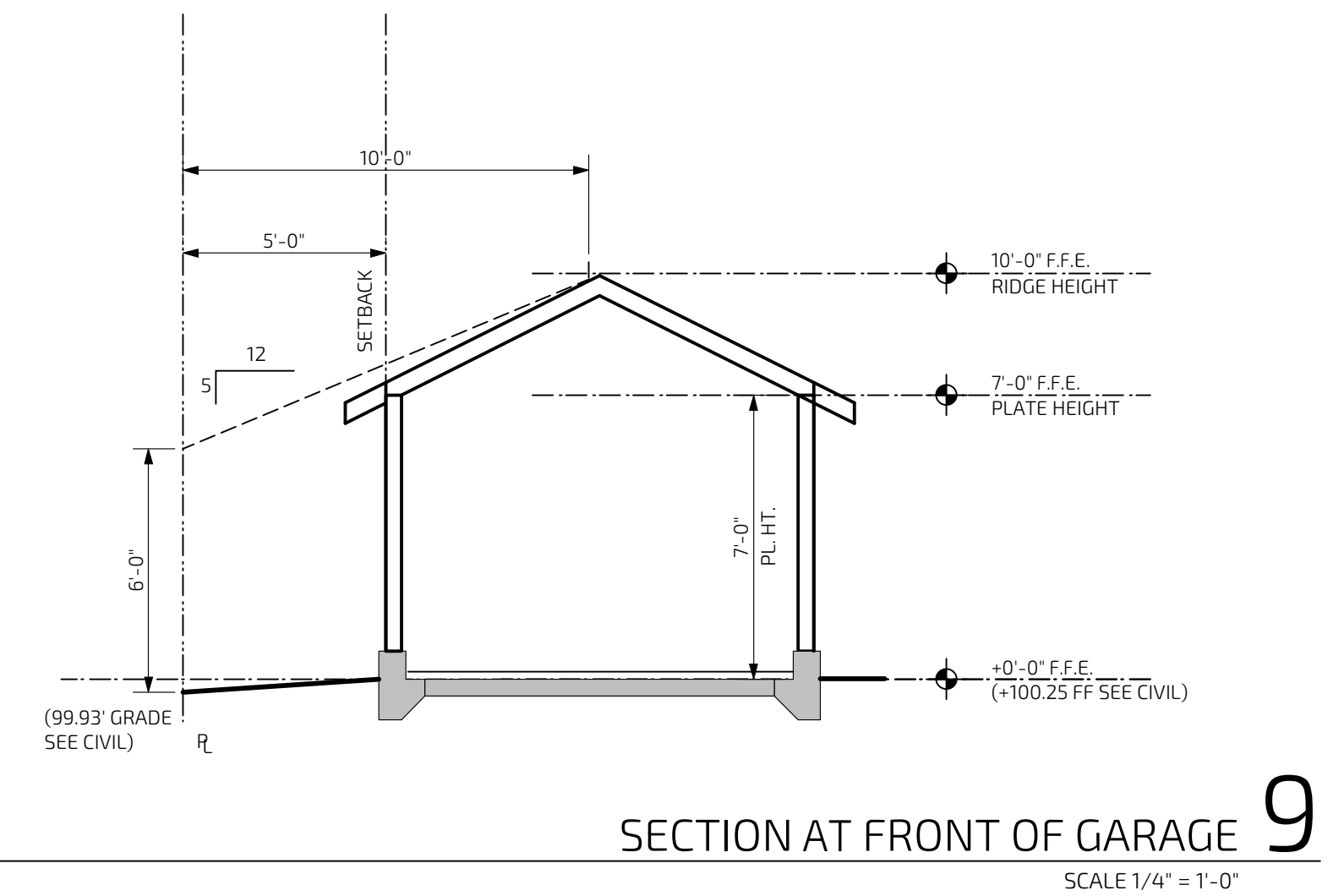
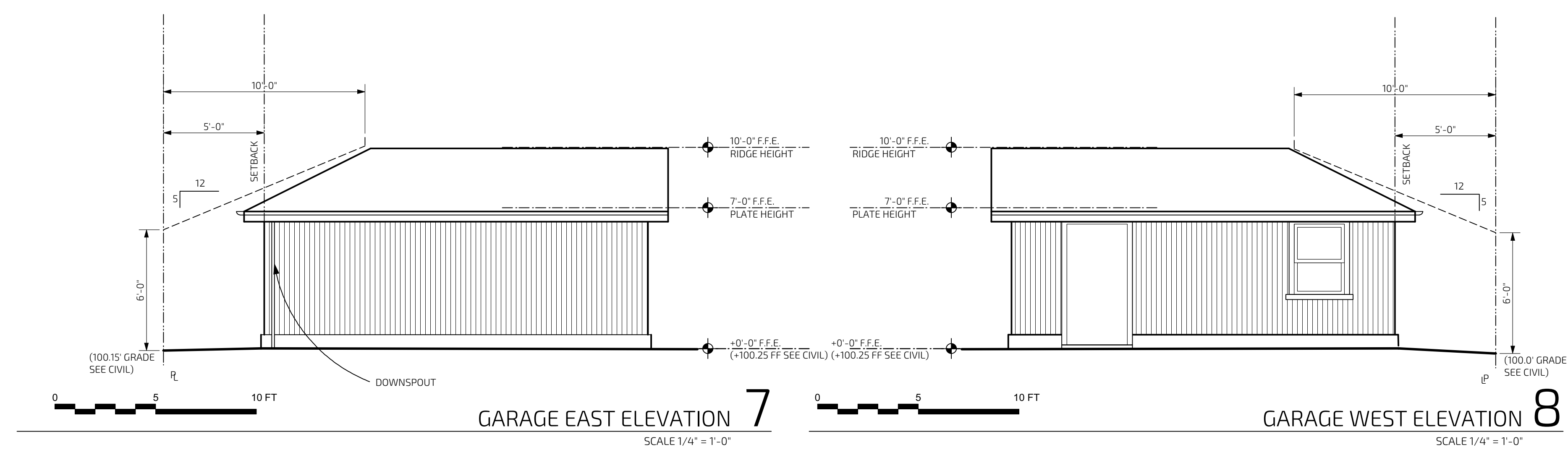

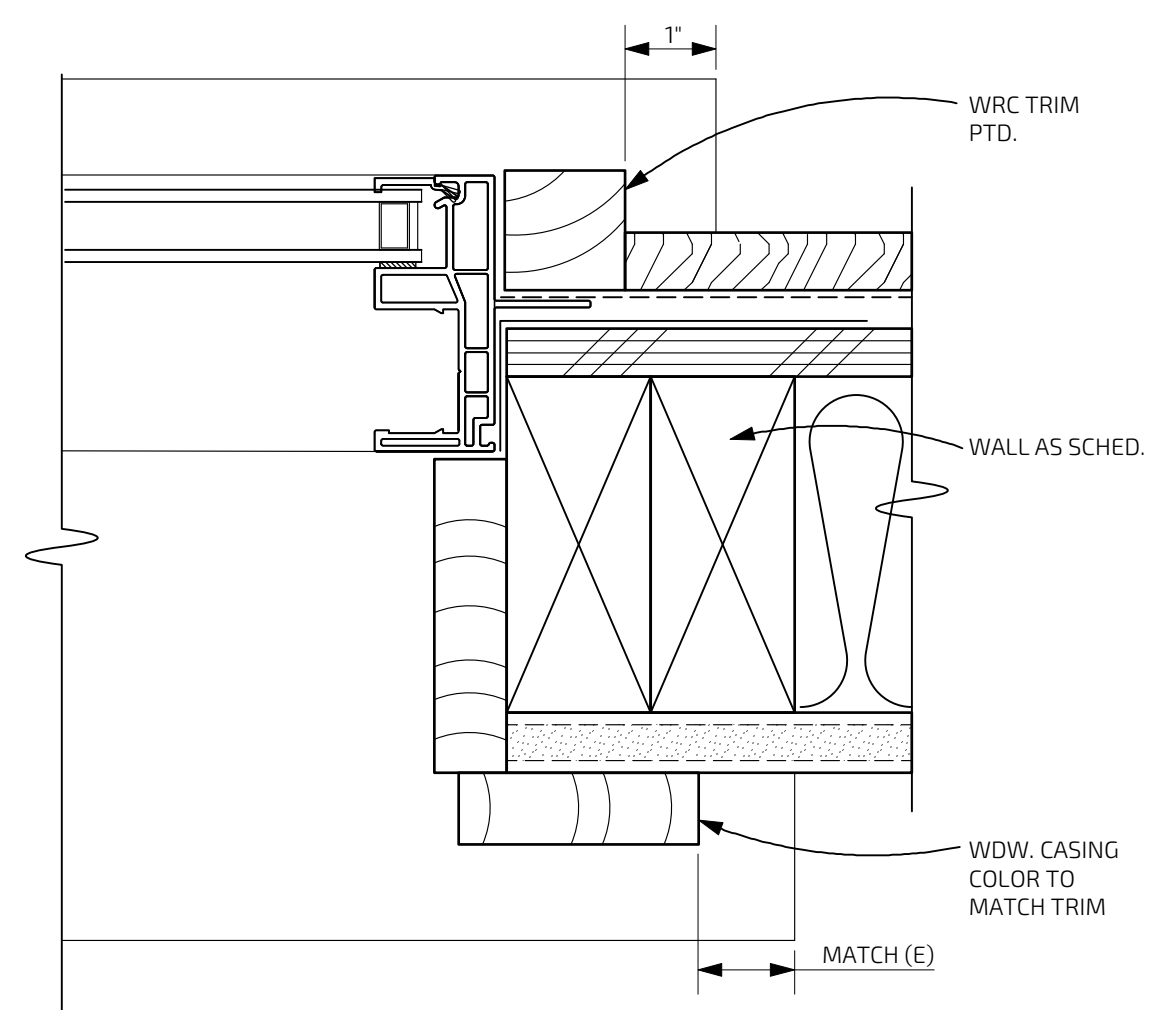
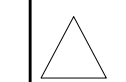

TYP. WDW. JAMB DETAIL @ CEMENT PLASTER FINISH 11

SCALE 6" = 1'-0"

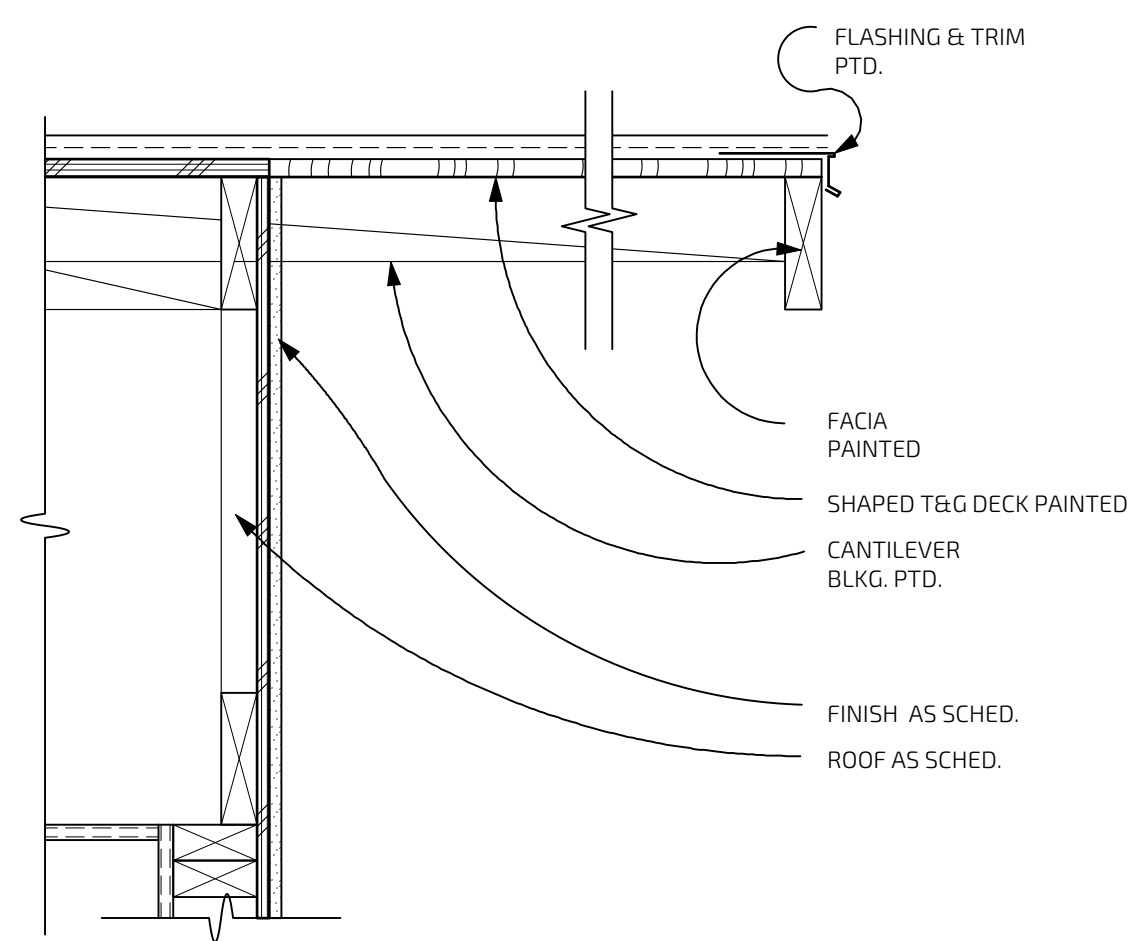

GABLE AT RIDGE 9

SCALE 1-1/2" = 1'-0"

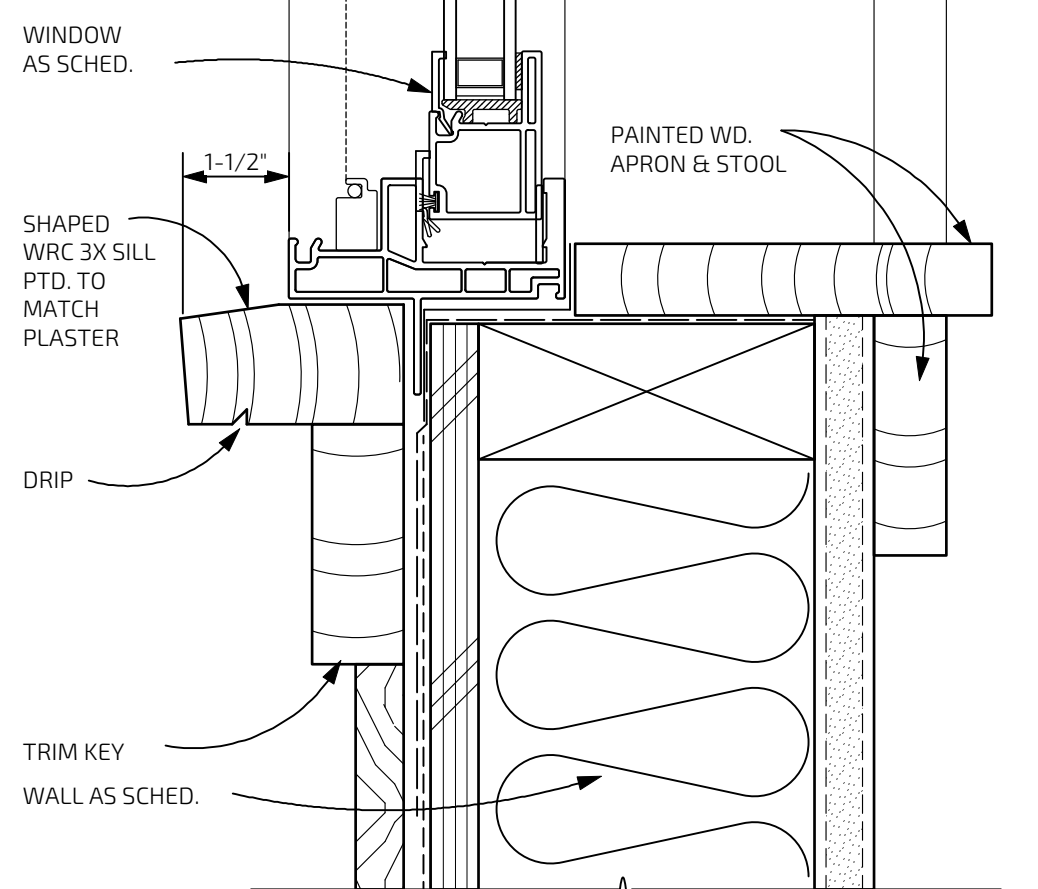
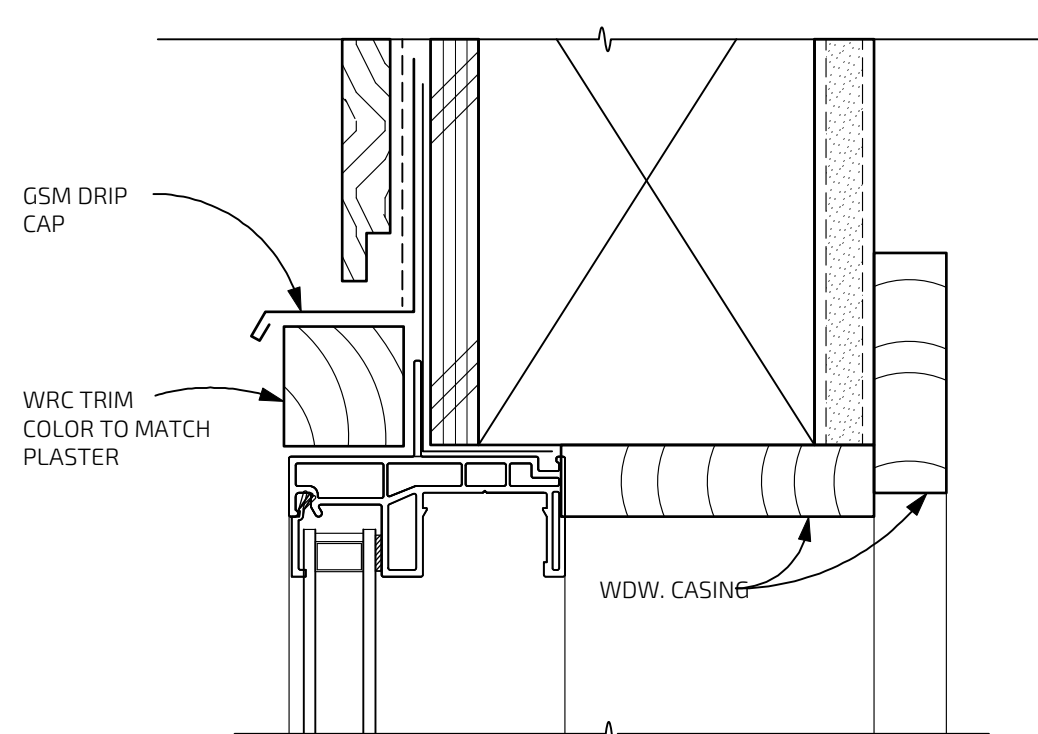

TYPICAL WDW. SILL, MEETING RAIL & HEAD DETAILS @ CEM. PLASTER FINISH (DR HEAD SIM.) 10

SCALE: 6" = 1'-0"

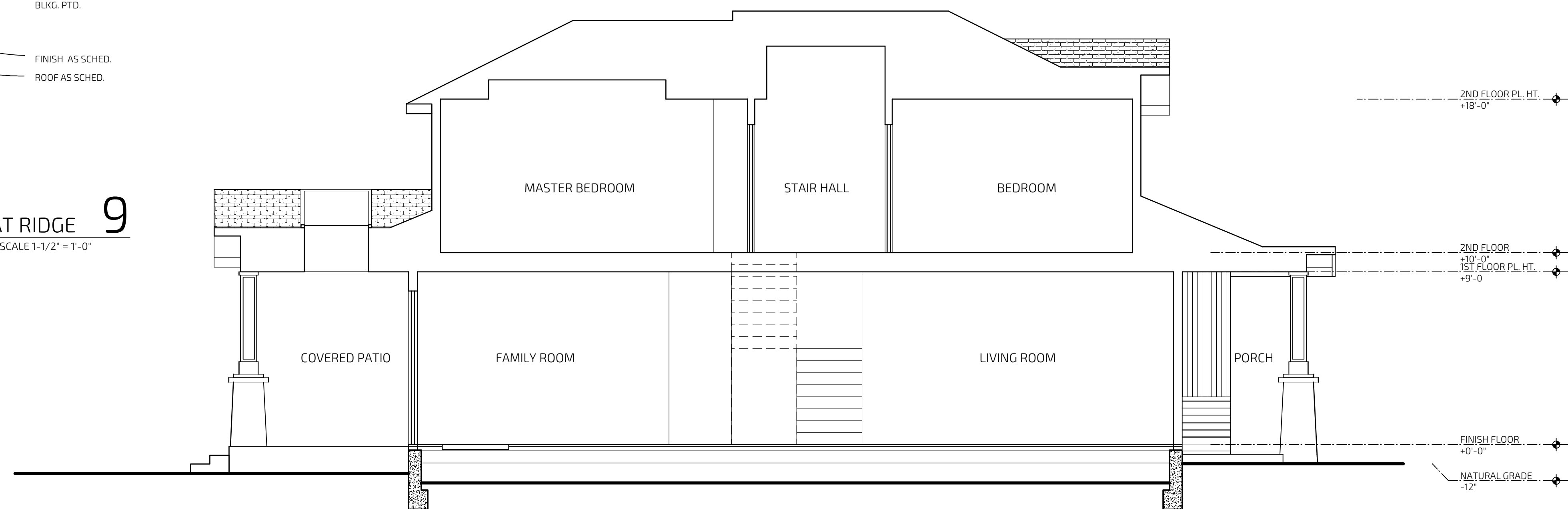

PROPOSED EAST (LEFT) ELEVATION 2

SCALE 1/4" = 1'-0"

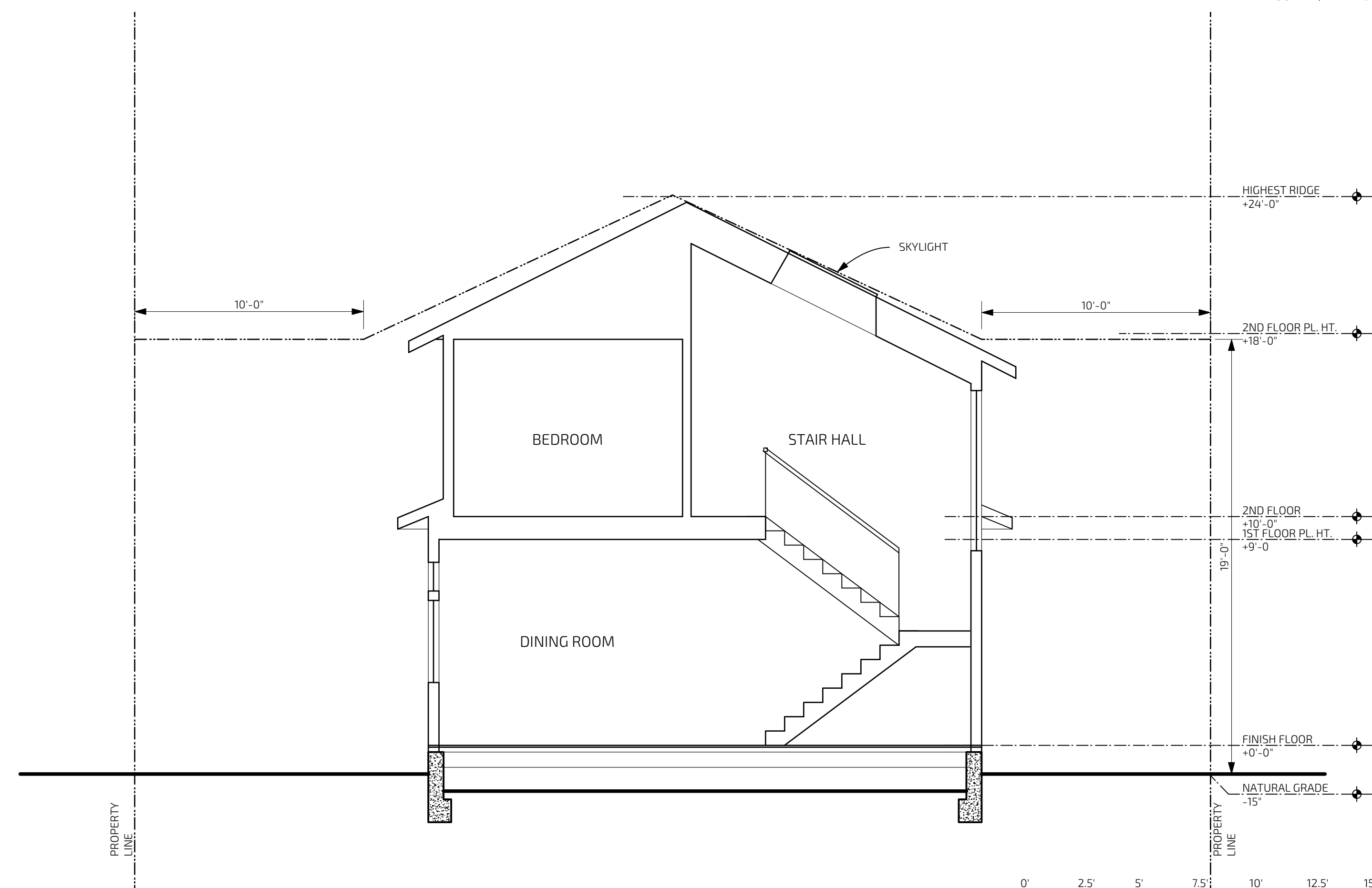

PROPOSED NORTH (FRONT) ELEVATION 1

SCALE 1/4" = 1'-0"

10-16-18  
11-28-18  
1-28-19  
2-22-19  
3-9-19  
4-17-19

WLU RESIDENCE  
NEW RESIDENCE  
163 DEL MONTE AVENUE  
LOS ALTOS, CA 94022

LANDSCAPE  
PLAN

L.1

SCALE 1/8"=1'

Symbol	Botanic Name	Common Name	Size	Quan.	Type	WUCCOLS
T1	Pyrus c. 'Redspire'	Flowering Pear	15g	3	Street tree	M
	Prunus laurocerasus	English Laurel	15g	13	Standard trunk	M
	Prunus c. 'Compacta'	Cherry Laurel	15g	23	Standard trunk	L
	Agapanthus 'Peter Pan'	Lily of the Nile	1g	12	Perennial	M
	Ceanothus hearstiorum	Ceanothus	1g	25	Ground Cover	VL
	Lomandra l. 'Breeze'	Dwarf Mat Rush	5g	16	Grass	L
	Phlomis fruticosa	Jerusalem Sage	5g	3	Shrub	L
	Trachelospermum jasminoides	Star Jasmine	5g staked	4	Vine	M
I have complied with the criteria of the ordinance and applied them for the efficient use of water in the landscape and irrigation plan. <i>Amy Mears</i>						

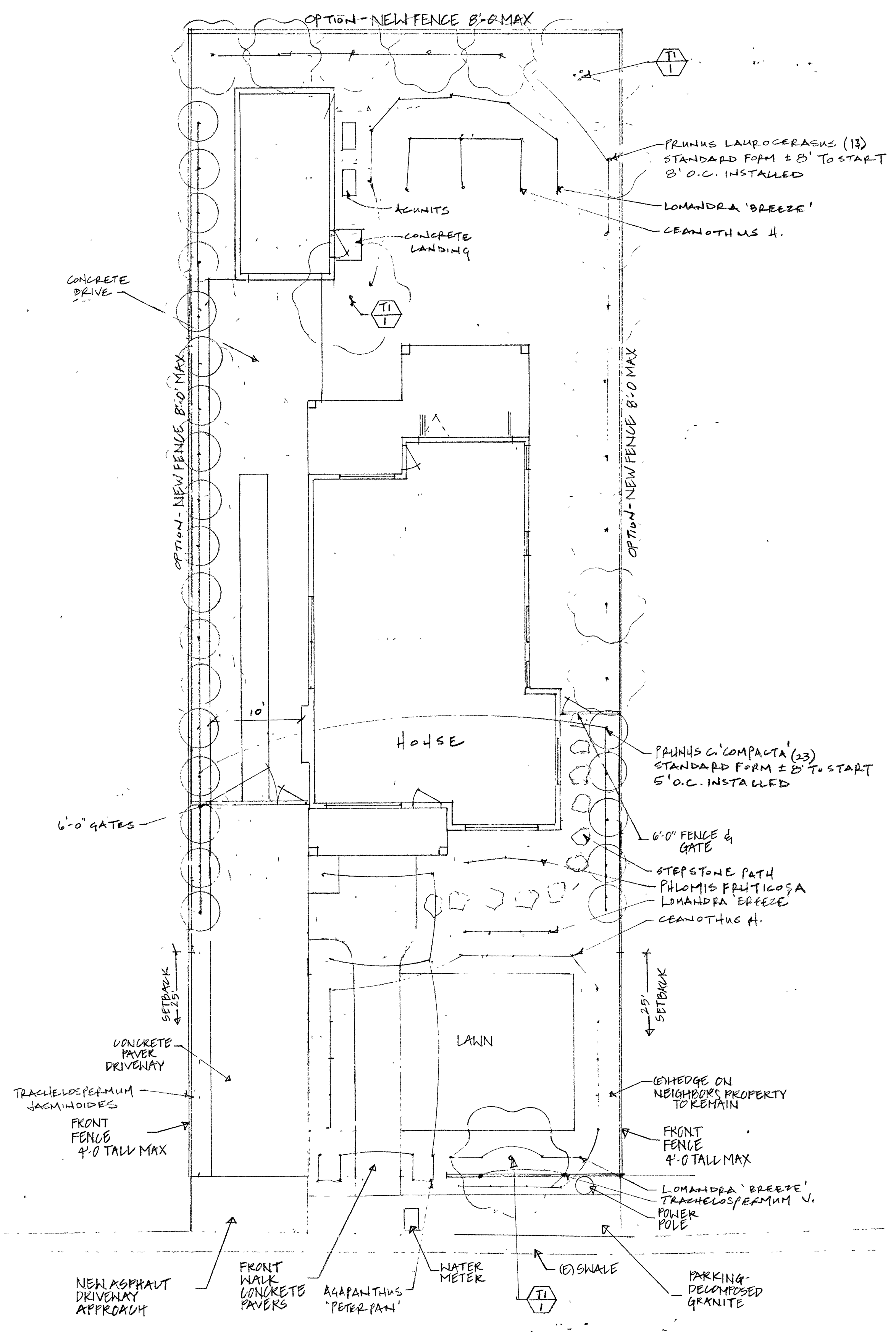

**WU RESIDENCE**  
 1.63 DEL MONTE AVENUE, LOS ALTOS, CA 94022

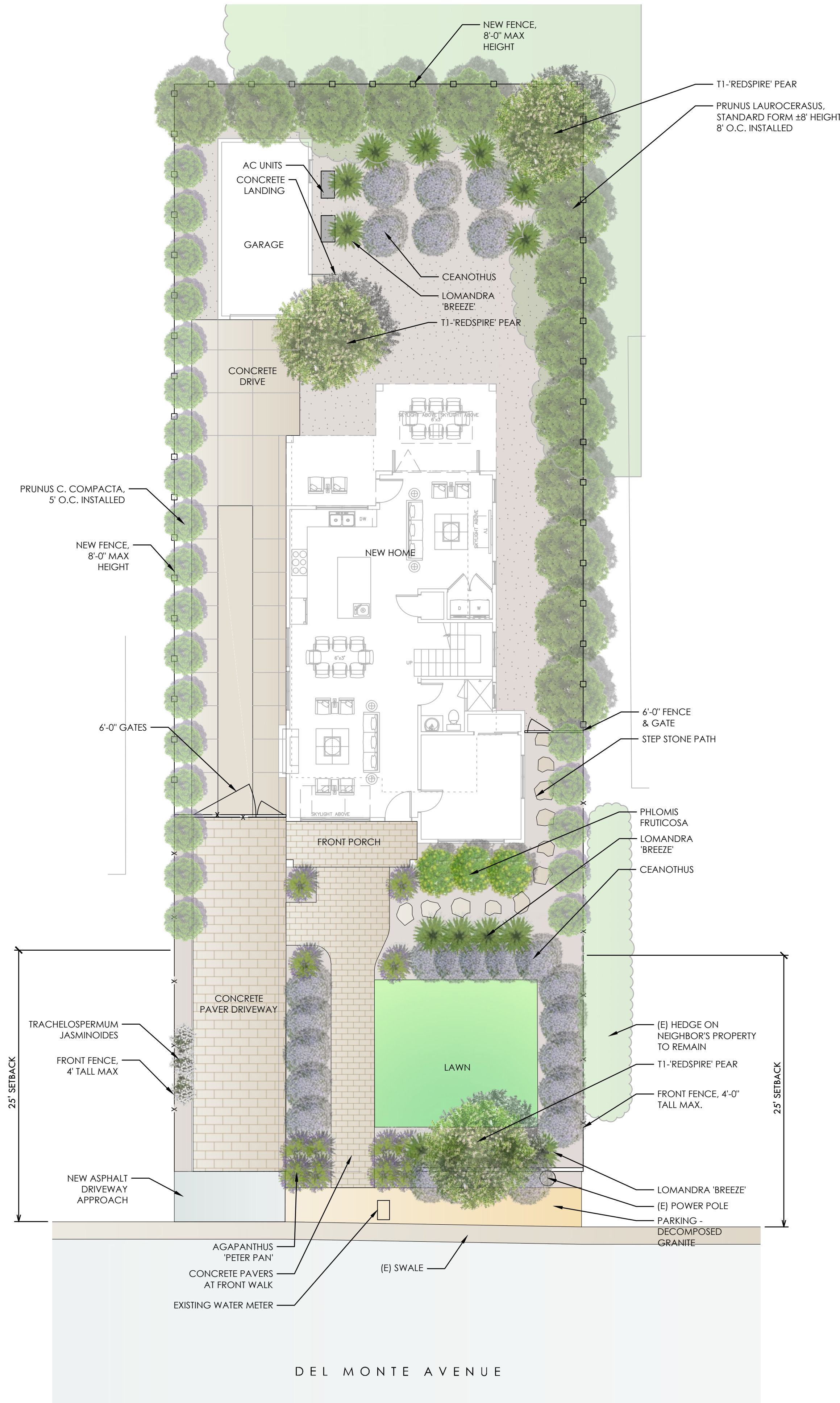

Symbol	Botanic Name	Common Name	Size	Quan.	Type	WUCCOLS
T1	Pyrus c. 'Redspire'	Flowering Pear	15g	3	Street tree	M
	Prunus laurocerasus	English Laurel	15g	13	Standard trunk	M
	Prunus c. 'Compacta'	Cherry Laurel	15g	23	Standard trunk	L
	Agapanthus 'Peter Pan'	Lily of the Nile	1g	12	Perennial	M
	Ceanothus hearstiorum	Ceanothus	1g	25	Ground Cover	VL
	Lomandra l. 'Breeze'	Dwarf Mat Rush	5g	16	Grass	L
	Phlomis fruticosa	Jerusalem Sage	5g	3	Shrub	L
	Trachelospermum jasminoides	Star Jasmine	5g staked	4	Vine	M
I have complied with the criteria of the ordinance and applied them for the efficient use of water in the landscape and irrigation plan. <i>Amy Mears</i>						

ILLUSTRATIVE SITE PLAN

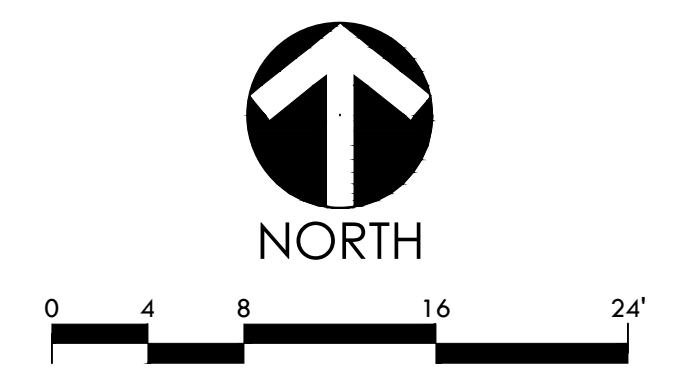

SUBMITAL	DATE

NO.	REVISIONS	DATE

DATE: MARCH 13, 2019  
 SCALE: 1/8" = 1' - 0"  
 DESIGNED: AM  
 DRAWN: PH  
 JOB NO: **18-002**

SHEET TITLE:  
**ILLUSTRATIVE SITE PLAN**  
 SHEET NAME:  
**L2**