

Cuesta Drive-Arboleda Drive Traffic Calming Project

TS-01022

Project Rescope Proposal



COMPLETE STREETS COMMISSION

MARCH 27, 2019

Project Location Map

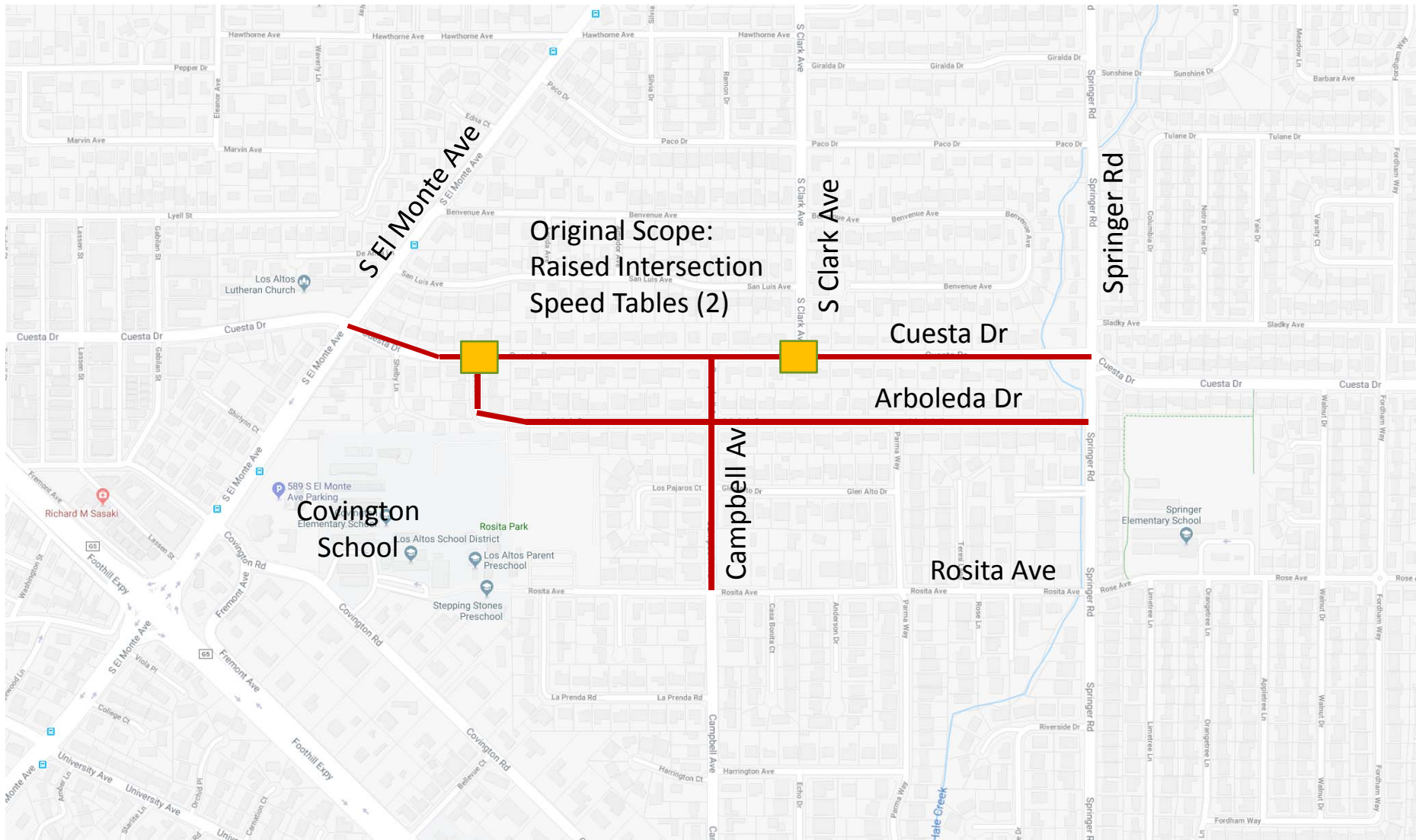

Community Outreach

Cuesta Dr-Arboleda Dr Traffic Calming Project

Traditional Outreach:

- Mailers
- Door Posting
- Advertising Signs on Street
- Flyers at City Facilities

Social Media Outreach:

- City Website/Calendar
 - NextDoor, Facebook, Twitter, Instagram
 - City Manager Weekly
 - Notice to Town Crier for Story
- 

Mailer



Community Meeting Notice:

Cuesta Drive – Arboleda Drive Traffic Calming Project Open House Meeting

The City of Los Altos is hosting an Open House meeting for residents to provide input on new concept plans for the Cuesta Drive-Arboleda Drive Traffic Calming project.

When:

Wednesday,
March 27, 2019
6:00pm – 7:00 pm

Where:

Los Altos City Council Chambers
1 N San Antonio Road
Los Altos, CA



This is the second open house for this project. The revised project work scope, based on resident input, includes traffic calming improvements on Cuesta Drive and Arboleda Drive including Campbell Avenue. Residents are encouraged to attend to learn about the project and provide input. The Open House will be followed by a focused discussion as part of the Complete Streets Commission monthly meeting starting at 7:00pm in the same meeting location.

Learn more about this project at: www.losaltosca.gov/CuestaDrive-ArboledaDrive

722
Parcels
--
895
Mailers

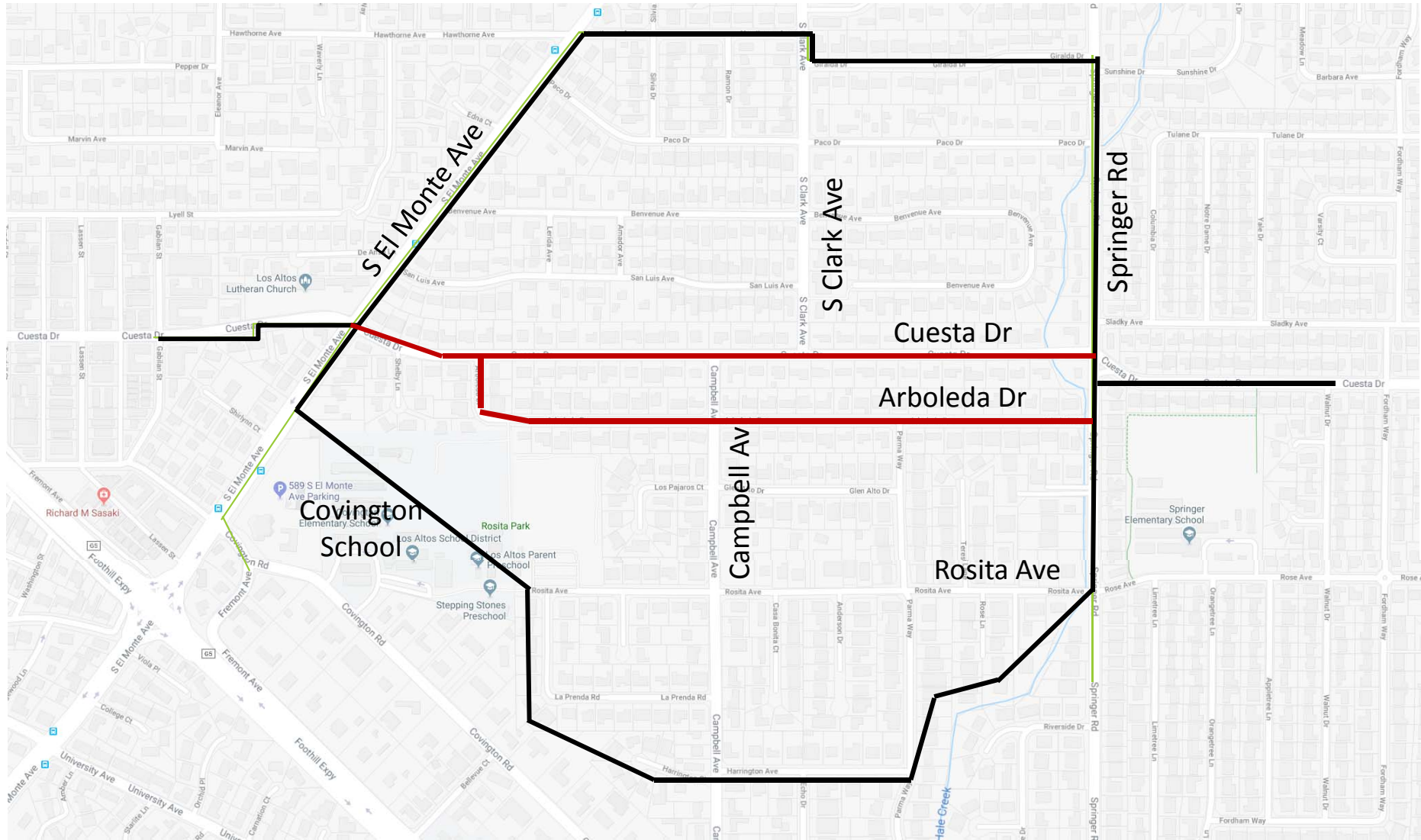

Request to Community and CSC

Cuesta Dr-Arboleda Dr Traffic Calming Project

Consider Project Rescope:

- Eliminate the Raised Intersection Speed Tables
- Include Traffic Calming Measures on Arboleda Dr with Project
- Include Campbell Ave for SR2S Accommodations

Project Proposals:

- Speed Tables on Cuesta Dr
Policy Approval Required
- Speed Humps on Arboleda Dr
Policy Approval Required
- Multi-Way STOP Options
Pending Community Input and Study Findings
- Crosswalk Enhancements

Los Altos Collector Traffic Calming

Ex. Policy Guidelines

Allowed Project Elements:

- Bulbouts
- Chokers
- Raised Crosswalks
- Mini-Roundabout
- Medians
- Raised Intersections
- Speed Tables
- Surface Treatments/Bike Lanes

Cuesta Drive Approved Treatments:

- Raised Medians
- Raised Intersections

Existing Policy Program Cuesta Drive



City of Los Altos

Collector Traffic Calming Plan

4.6 Cuesta Drive: Springer Road to El Monte Avenue

Surrounding Land Uses: Between Springer Road and El Monte Avenue, Cuesta Drive consists of single-family residential homes. Access to the homes is taken directly from Cuesta Drive. Parking is allowed on both sides of the street.

Traffic Concerns: Measured traffic speeds exceed the speed limit by 10 mph, which restricts enforcement by radar. Cuesta Drive carries over 7,000 vehicles per day, which is high compared to similar collector roadways in the City of Los Altos. Cuesta is an east-west connector between San Antonio Road and Springer Road. Therefore, this roadway is used as a thoroughfare for many users. Sidewalks and Class III bicycle facilities are currently provided.



Recommended Tools: The tools selected for this section aim to reduce traffic speeds to conform with the posted speed limit. The characteristics of Cuesta Drive are suitable for vertical and horizontal deflection. The ability to apply horizontal devices such as bulbouts or chokers may be limited due to restricted right-of-way, lack of sidewalk and on-street parking. Where horizontal devices are selected, sufficient distance along the shoulder should be provided for pedestrians and bicycles along the shoulder.

To successfully slow traffic to the desired speed range (25-30 mph) the devices should be spaced close together (500 to 800 feet) and should work together as a system to avoid diversion of traffic to local streets and to maintain consistently lower speeds along the corridor. All proposed improvements will compliment the Blach School Neighborhood Traffic Study.

As such, the following devices were identified as feasible:

- **Raised Medians:** reduce speeds up to 5% by narrowing the width of the travel lanes
- **Raised Intersection:** up to 10% reduction in speed

Working together, these traffic calming devices are anticipated to result in an average 5 to 10 mph decrease in speed along Cuesta Drive. Medians are recommended to visually and physically narrow the roadway to reduce speeds through much of the length of the corridor. A raised intersection is proposed at the intersection of Cuesta Drive and Arboleda Drive, which provides access to the southern portion of the neighborhood.

Traffic Data

85th Percentile Speeds

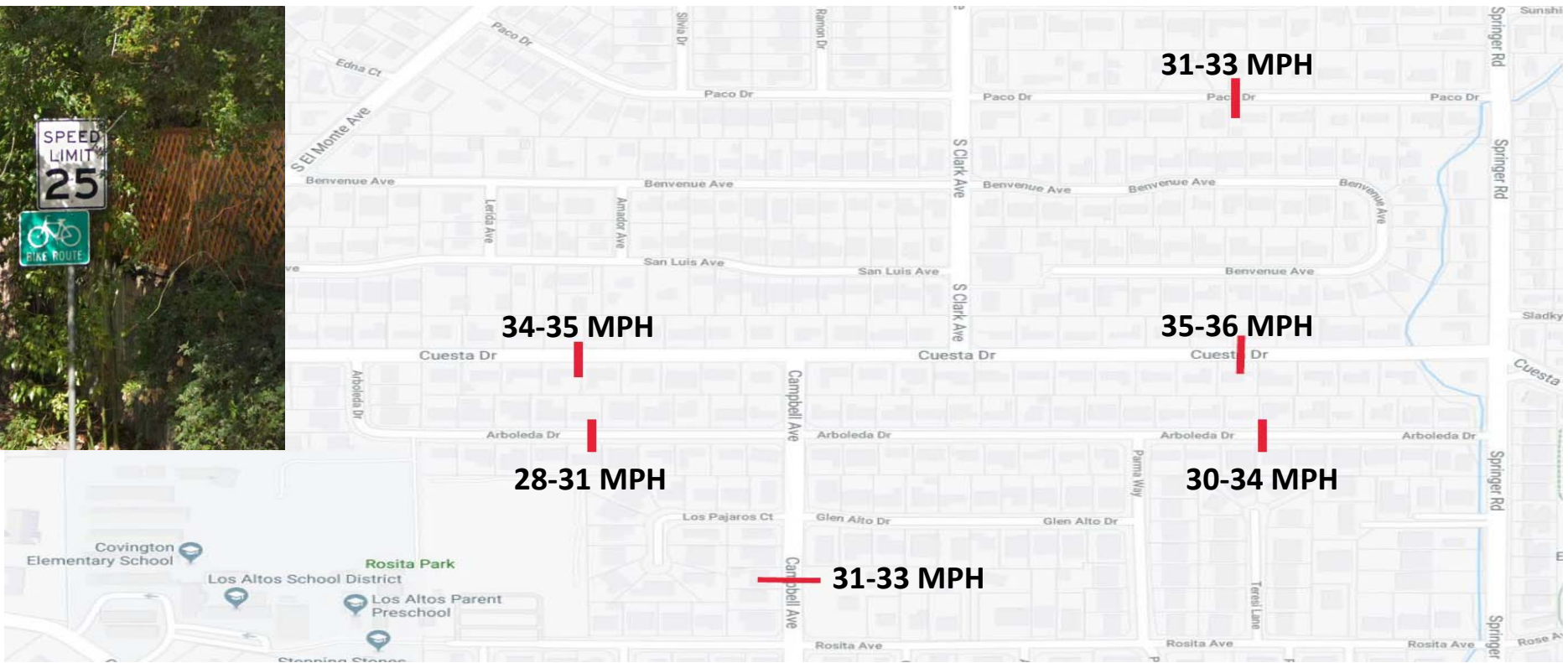

Traffic Data

Turning Movement Count Locations

12-Hour Counts (7:00 AM – 7:00 PM)

Multi-Modal: Autos, Pedestrians, Bicycles

- Cuesta Drive & Arboleda Drive
- Cuesta Drive & Campbell Avenue
- Cuesta Drive & S. Clark Avenue
- Cuesta Drive & Springer Road
- Campbell Avenue & Arboleda Drive
- Campbell Avenue & Rosita Avenue

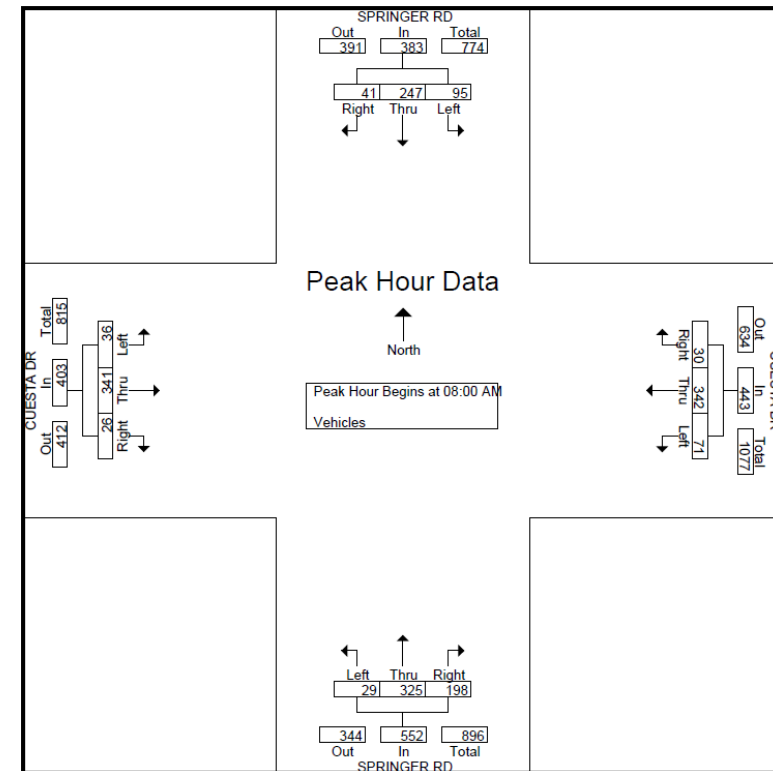

Traffic Analysis Intersection Study Types

Intersections to Analyze:

- Cuesta Drive & Arboleda Drive
- Cuesta Drive & Campbell Avenue
- Cuesta Drive & S. Clark Avenue
- Cuesta Drive & Springer Road
- Campbell Avenue & Arboleda Drive
- Campbell Avenue & Rosita Avenue

Analysis Will Include:

- Intersection Level of Service (LOS)
- Intersection Approach Delay
- Intersection Approach Queueing

These analyses will look at the AM and PM Peak Hour Periods, comparing existing to proposed conditions.



Traffic Analysis

Multi-Way STOP Studies

Considered at:

- Cuesta Drive & Arboleda Drive
- Cuesta Drive & S. Clark Avenue
- Campbell Avenue & Arboleda Drive
- Campbell Avenue & Rosita Avenue

Analysis Considers:

- Vehicle Volumes
- Vehicle Delays
- Collision Reports at the Intersections



Multi-Way STOP Studies

Preliminary Level of Service (LOS) Findings

Conducted by **Traffic Patterns**

Intersection	AM Existing	PM Existing	AM Proposed	PM Proposed
Cuesta / Arboleda	-	-	B	B
Cuesta / Campbell	C	B	C	B
Cuesta / Clark	-	-	B	B
Campbell / Arboleda	-	-	A	A
Campbell / Rosita	-	-	A	A

Notes:

- Focused Traffic Study Pending
- Level of Service (LOS) Study for Ex. Traffic Signal at Cuesta Dr & S El Monte Ave still Pending
- Level of Service (LOS) Study for Ex. Multi-Way STOP At Cuesta Dr & Springer still Pending

Improvement Options Cuesta Drive & Arboleda Drive

3 Options:

Option 1 – All Way Stop Control
(Pending Study)

Option 2 – Maintain Stop on Arboleda.
Install Raised Crosswalk across
Cuesta Drive.

Option 3 – Maintain Stop on Arboleda.
Install Painted Curb Extensions at
the corners.
Install Speed Table West on Cuesta
between Shelby and Arboleda.

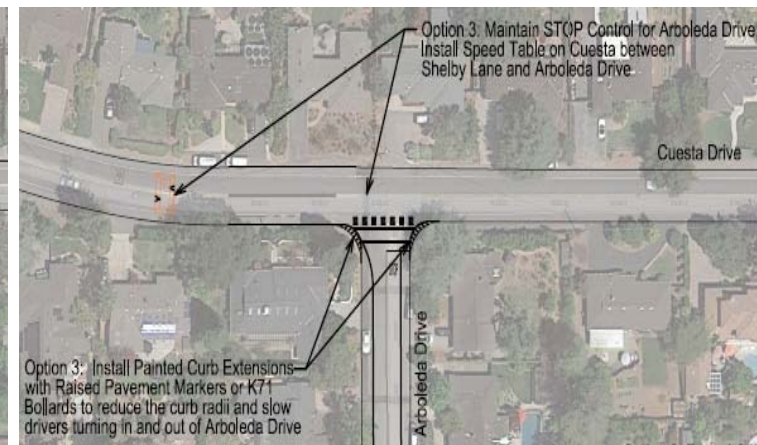
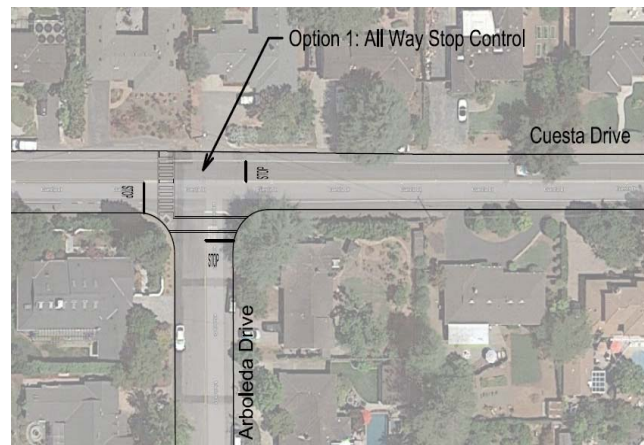

Improvement Options Cuesta Drive & Campbell Avenue

2 Options:

Option 1 – Maintain Multi-Way Stop.
Refresh Crosswalk Stripping



Option 2 – Maintain Multi-Way Stop.
Install Raised Crosswalk
across Cuesta Drive



Improvement Options Cuesta Drive & S Clark Avenue Cuesta Drive & Springer Avenue

Cuesta Drive & S. Clark Avenue
All Way Stop Control
(Pending Study)

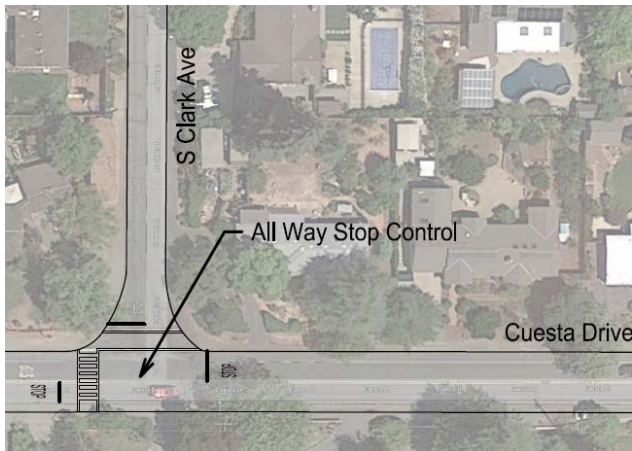

Cuesta Drive & Springer Road
Perform Traffic Study to Determine Impacts of
Reducing the SB Cuesta Drive approach to 1 Lane



Proposed Traffic Calming Measures Cuesta Drive

Cuesta Drive Design Elements:

- **Speed Tables**
Located at Midblock Locations
- **Visual Lane Narrowing**
Throughout Corridor
- **Painted Curb Extensions**
Potentially at Cuesta/Arboleda
- **Green Dashed/Conflict Striping**
Potentially Across Intersections

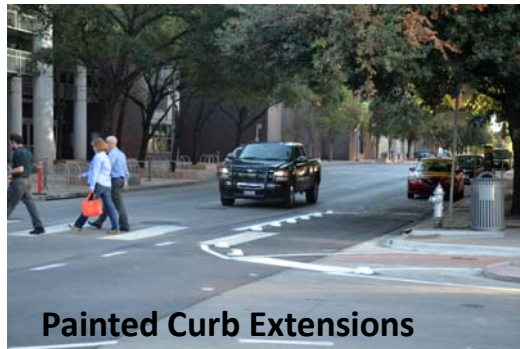
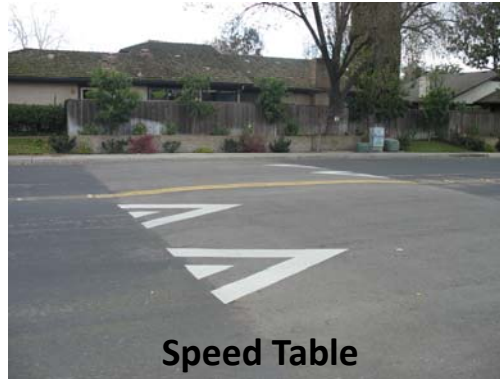

Improvement Options Arboleda Drive & School Crossing

3 Options:

Option 1 – Striped Crosswalk and potential for Solar Lighting.

Parking Restrictions
Approaching Crosswalk to
Improve Sight Distance.

Option 2 – Crosswalk with Median Islands and potential for Solar Lighting.

Speed Hump before Curve

Parking Restrictions
Approaching Crosswalk.

Option 3 – Raised Crosswalk/Speed Table

Stripe Edgelines to narrow travel
and Create Pedestrian Space
Leading to School Entrance.

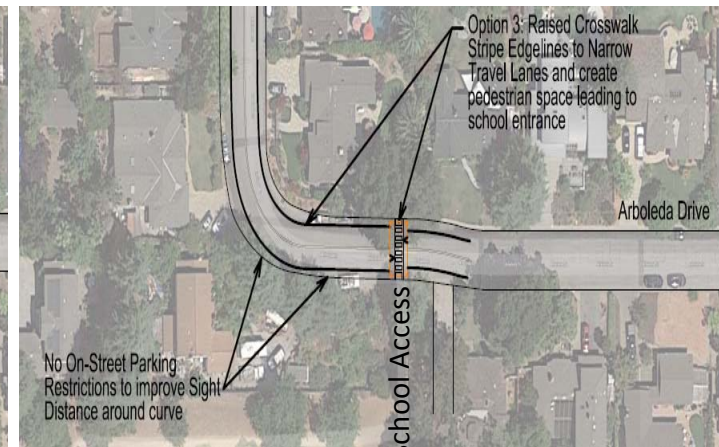
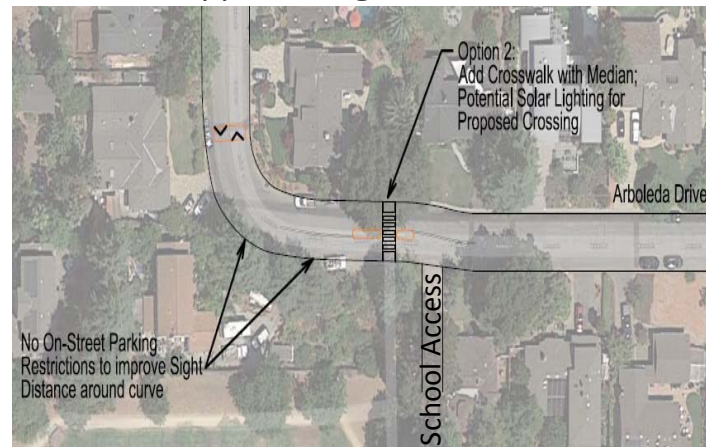
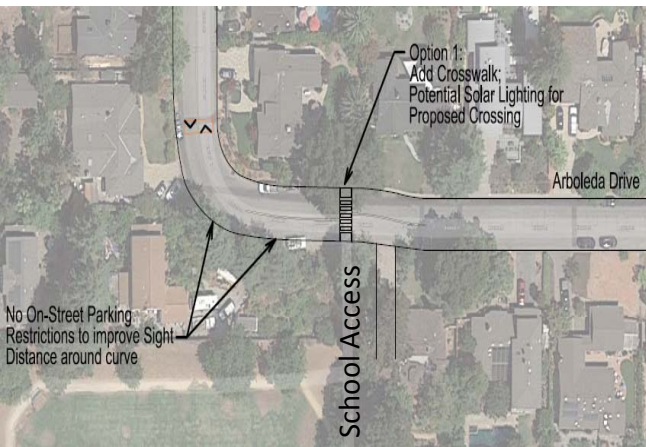

Improvement Options Arboleda Drive & Campbell Avenue

2 Options:

Option 1 – All Way STOP Control

Option 2 – Maintain Ex. 2-Way STOP Control

Crosswalks across Campbell Avenue

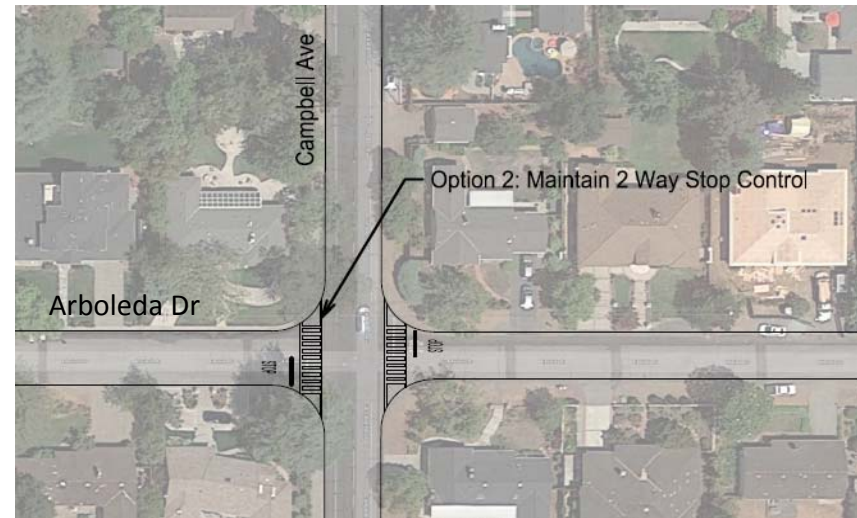
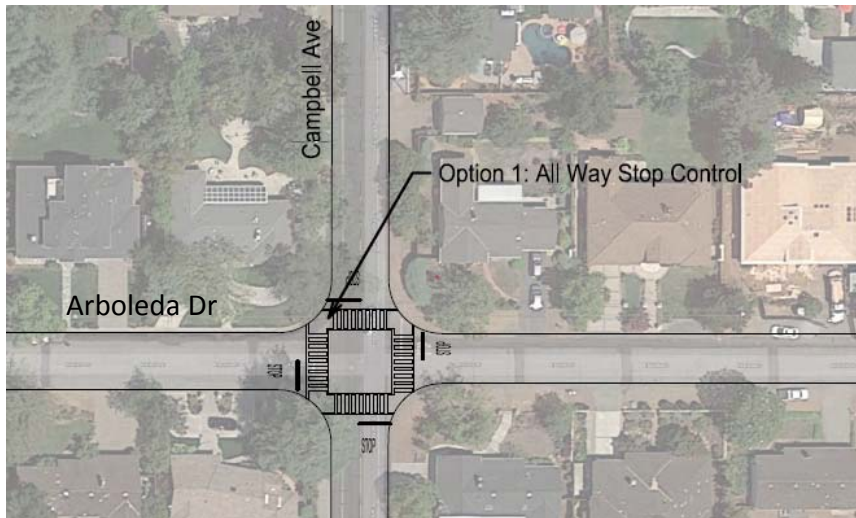

Proposed Traffic Calming Measures Arboleda Drive

Arboleda Drive Design Elements:

- **Speed Humps**
Located at Midblock Locations
- **Painted Curb Extensions**
Potentially at Arboleda Dr & Springer Rd

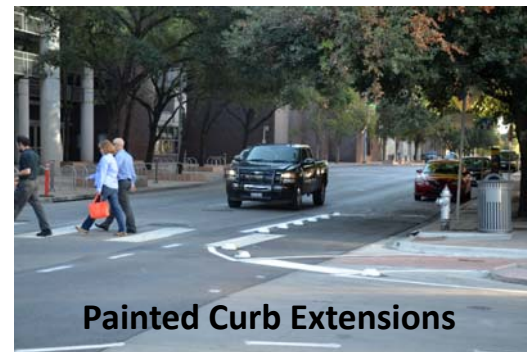

Recommendation

Staff Recommends that the Complete Streets Commission provide input on the proposed rescoping options for the Cuesta Drive-Arboleda Drive Traffic Calming Project. Include a recommendation to the City Council to allow a Policy Change for Collector Street traffic calming improvements along Cuesta Dr.

Questions?

Existing Policy Program Cuesta Drive

**Figure 2: Los Altos Collector
Traffic Calming Plan
Proposed Improvements Map**

