



PUBLIC HEARING

Agenda Item # 3

AGENDA REPORT SUMMARY

Meeting Date: September 8, 2020

Subject: Repeal and Replace Chapter 14.14 of the Los Altos Municipal Code (Accessory and Junior Dwelling Units) by adopting Zoning Text Amendment 20-0001

Prepared by: Guido F. Persicone, Planning Services Manager, AICP
Erik Ramakrishnan, Deputy City Attorney

Reviewed by: Jon Biggs, Community Development Director and
Jolie Houston, City Attorney

Attachment(s):

1. Draft ADU Ordinance-Marked Up Version
2. Draft ADU Ordinance-Clean Version
3. July 14, 2020 City Council Staff Report
4. June 18, 2020 Planning Commission Staff Report
5. May 21, 2020 Planning Commission Staff Report
6. May 7, 2020 Planning Commission Staff Report
7. April 16, 2020 Planning Commission Staff Report
8. April 16, 2020 Planning Commission Meeting Minutes
9. May 7, 2020 Planning Commission Meeting Minutes
10. Community Comment, dated August 13, 2020

Initiated by:

City staff due to recent changes to state law.

Previous Council Consideration:

July 14, 2020

Fiscal Impact:

No direct fiscal impact is anticipated.

Environmental Review:

Adoption of an accessory dwelling unit ordinance is subject to a statutory exemption from environmental review (Public Resource Code Section 15282(h)). In addition, the action being considered does not constitute a “project” within the meaning of the California Environmental Quality Act (“CEQA”) pursuant to CEQA Guidelines Section 15061(b)(3) as the activity is covered by the general rule that CEQA applies only to projects which have the potential for causing a significant effect on the environment. Where it can be seen with certainty that there is no possibility that the activity in question may have a significant effect on the environment, the activity is not subject to CEQA. Projects that are subject to the ADU regulations will be evaluated pursuant to



Subject: Proposed Amendments to the Chapter 14.14 (Accessory Dwelling Unit) Ordinance
Second Planning Commission Meeting

CEQA on an individual basis. However, ADUs are generally exempt from CEQA review under CEQA Guidelines Section 15268 (Ministerial Projects, Section 15301 (Existing Facilities), and/or Section 15303 (New Construction or Conversion of Small Structures).

Policy Question(s) for Council Consideration:

- Do the proposed code amendments ensure the Los Altos Municipal Code is consistent with recent changes to state law?

Summary:

- The ordinance repeals and replaces Chapter 14.14, Accessory Dwelling Units, to ensure consistency with State law.

Staff Recommendation:

The Planning Commission and staff recommend that the City Council introduce and waive further reading of the proposed ordinance

Purpose

The purpose of the proposed amendments is to ensure compliance with new state laws affecting the development of accessory dwelling units and junior accessory dwelling units in the residential zone districts of the City.

Background

On April 16, 2020 the Planning Commission reviewed the draft accessory dwelling unit ordinance (ADU). At the conclusion of the meeting, the Commission requested that the ordinance be revised and brought back for consideration at the next Planning Commission meeting.

In addition to the Commission's edits, on the day of the hearing the State office of Housing and Community Development Department (State HCD) reached out to City staff to provide some direction on edits that would be necessary to receive State support for the draft ordinance. This was extremely helpful as State approval within sixty (60) days of adoption is a legal requirement of the most recent legislation.

On May 7, 2020, the Planning Commission reviewed the draft ordinance and directed staff to bring the ordinance back for review at the May 21, 2020 meeting.

On May 21, 2020, approximately forty-five minutes before the public hearing, City staff received a detailed letter from an attorney representing Californian's For Homeownership. Due to the detailed comments, City staff requested, and the Commission agreed, that continuing the item to the June 4,



Subject: Proposed Amendments to the Chapter 14.14 (Accessory Dwelling Unit) Ordinance
Second Planning Commission Meeting

2020 meeting would be the best scenario so the City could adequately respond to the comment letter.

After publication of the June 4, 2020 staff report City staff met with State HCD. They requested several additional edits to the draft document. As a result of these edits the Planning Commission agreed to continue the item to the June 18, 2020 meeting. It should be noted that a lot of the requested edits from State HCD were driven by the Californian's for Homeownership group an organization established by California Association of Realtors.

On June 18, 2020, the Planning Commission recommended approval of the Zoning Text Amendment, project reference No. Amendment ZTA 20-0001.

On July 14, 2020, the City Council directed staff to make the following edits and to bring the ordinance back for review. During the July City Council meeting, input was provided by the Council for each individual section of the ordinance. The same format will be followed for this report and the presentation to the Council

Section 14.14.010 Purpose and Intent

The terms JADU and ADU are used consistently throughout the entire ordinance.

Section 14.14.020

Include a definition for a detached accessory dwelling unit. This definition has been added.

“Accessory dwelling unit, detached.” A detached accessory dwelling unit means an ADU which is constructed as an independent structure, surrounded by open space and on the same lot as the primary single family residential dwelling unit or a multifamily housing development , except that it can be attached to an accessory structure (e.g., garage).

Also, a definition for what constitutes a primary single-family dwelling unit, the following from the Los Altos General Plan, was added.

“Primary single-family residential dwelling unit” A dwelling, not attached to any other dwelling, which is designed for and occupied by not more than one household and is surrounded by open space or yards.

Section 14.14.021

When appropriate include the term JADU to clarify intent and purpose.

Utility Fees and Connections table was amended to make it clear that an attached or detached ADU may be serviced by the primary home or have separate utilities.



Subject: Proposed Amendments to the Chapter 14.14 (Accessory Dwelling Unit) Ordinance
Second Planning Commission Meeting

<i>Utility Fees and Connections</i>	<i>None required.</i>	<i>The accessory dwelling may be served by the primary <u>single-family residential dwelling unit</u> or may have separate utility meters.</i>
--	-----------------------	--

Section 14.14.025

Attached and Detached ADUs-the definition of size for an attached or detached were modified in this section to match the proposed edits later in Section 14.14.050(d)

It has been clarified that approval of an ADU above 850 square feet would be contingent on the property having the appropriate FAR for the lot.

<i>Accessory dwelling unit subject to objective design standards</i>	<i>An ADU between 851-1,200 square feet are subject to a zoning clearance review for objective design standards as identified in Chapter 14.06-Chapter 14.16-24. <u>An ADU may exceed 851 square feet only if the property has not exceeded the floor area ratio allowed for the lot per Chapter 14.06 of the Los Altos Municipal Code.</u></i>
--	---

Section 14.14.040 General Requirements.

The terms JADU and efficiency unit term were removed per direction from the City Council to make it clear that 14.14.040 applies only to ADUs and not JADU’s. Additional edits were made to ensure the correct nomenclature is used throughout the document.

Notwithstanding any local ordinance regulating the issuance of variances or special use permits, or regulations adopted herein to the contrary, an application to construct an accessory dwelling unit shall be approved or denied ministerial without discretionary review or hearing within sixty (60) days from the date the city receives a completed application if there is an existing single-family or multifamily structure on the lot. The following requirements apply to all ADUs:

(b) Except as allowed by State law, an accessory dwelling shall not be sold or have its title transferred separately from the primary single-family residential dwelling unit.

(c) Deed Restriction. Prior to the issuance of the building permit for the accessory dwelling unit, the owner must record a deed restriction stating that the accessory dwelling unit may not be rented for periods less than thirty (30) days, and that it may not be transferred or sold separate from the primary single-family residential dwelling unit.



Subject: Proposed Amendments to the Chapter 14.14 (Accessory Dwelling Unit) Ordinance
Second Planning Commission Meeting

Section 14.14.050- Single-Family Residential ADU Standards in Single Family Residential Zoning Districts

The title of this section was changed per City Council direction

Section-14.14.040.050 (b)-

This was rewritten to make it clear that a property can get 1 JADU and 1 detached ADU per lot.

(b) Number. For a lot with a proposed or existing single-family dwelling, one attached or detached, new construction ADU shall be permitted. In the case of a detached ADU that does not exceed 850 square feet in size nor 16 feet in height, and that provides at least four foot side and rear setbacks, the detached ADU may be established in addition to a JADU, as set forth in section 14.14.060

Section-14.14.040.050 (c)- Relationship to Primary Single-Family Residential Dwelling Unit. Changes were made to this section to ensure consistent nomenclature. Additionally, a cross reference was added to ensure the detached ADUs are at least 5 feet from the main house.

c) Relationship to Primary Single-Family Residential Dwelling Unit. A single-family residential accessory dwelling unit may be within, attached to, or detached from, the proposed or existing primary single family residential dwelling unit, provided that a single-family residential accessory dwelling unit contained within or attached to an existing primary single family residential dwelling unit shall have independent exterior access from the existing residence. A detached single-family residential accessory dwelling unit must be located at least five (5) feet from the proposed or existing primary dwelling per Section 14.14.050(f)(3).

Section-14.14.040.050 (d)-Size

This entire section was rewritten to make it clear that a 1 bedroom ADU can be up to 850 square feet and 1 bedroom or more can be no larger than 1,200 square feet. Additionally, City staff concurred with the Mayor that the verbiage related to the internal conversion of a house for an ADU was confusing, so a separate paragraph was added for clarity. Finally, Planning Commissioner Bressack's edits were incorporated as they related to building back square footage lost to an internal conversion of an ADU up to 850 square feet.

(d) Size.

*(1) A **detached** single-family residential ADU shall not exceed eight hundred fifty (850) square feet in floor area for one (1) bedroom units, or one thousand two-hundred (1,200) square feet for a detached ADU with more than one (1) bedroom. Additional square footage above 850 square feet shall be allowed only if the lot meets the lot coverage and floor area ratio requirements for the applicable zoning district. For **detached** accessory dwelling units, garage area is excluded but **basement areas are included** in the square footage calculation for the ADU.*



Subject: Proposed Amendments to the Chapter 14.14 (Accessory Dwelling Unit) Ordinance
Second Planning Commission Meeting

(2) An **attached** single family residential ADU shall not exceed eight hundred fifty (850) square feet in floor area for one bedroom units or one thousand two hundred (1,200) square feet for a attached accessory dwelling unit with more than one (1) bedroom. The total floor area for an attached ADU shall **exclude the basement areas**, and shall not be more than fifty (50) percent of the floor area of the existing or proposed principal residence. Notwithstanding this 50% threshold requirement, an attached ADU of 850 square feet or smaller cannot be denied. Additional square footage above 850 square feet shall be allowed only if the lot meets the lot coverage and area ratio requirements for the applicable zoning district.

(3) *Internal Attached ADU Conversion.* - There is no size limitation on an ADU that is created exclusively by converting space within the existing primary single family dwelling unit or accessory structure. If a homeowner converts a portion of the primary single family residential dwelling unit for an attached ADU, nothing herein shall prevent the homeowner from replacing the square footage lost, up to up to 850sf above FAR limits, subject to the applicable design rules for the specific zoning district.

14.14.050(f)(1-2, 4)-Setbacks

This section was completely rewritten to address a number of City Council issues: 1) for clarity; 2) to encourage the voluntary setback identified in 14.14.080;3) to add a separate paragraph regarding setbacks for an existing accessory structure to be converted to an ADU; and 4) to make it clear that mechanical equipment and other potential sources of noise must follow the City's Noise Ordinance.

(1) *A single-family residential accessory dwelling unit either attached or detached from the main house must not encroach upon the required front yard area and shall have at least four (4) foot setbacks at the rear and side yards per state law. Applicants are encouraged to comply voluntarily with the setbacks identified within 14.14.080 of ten (10) feet from the side and rear property lines to reduce privacy impacts. An accessory dwelling unit that provides such ten (10) foot setback shall be removed from daylight plane restrictions*

(2) *A setback of four (4) feet from the interior side and rear lot lines shall be required for a newly constructed, detached or attached single-family residential accessory dwelling unit. No setback shall be required for an existing living area or accessory structure or a structure constructed in the same location and to the same dimensions and within the same footprint as an existing structure that is converted to an accessory dwelling unit or to a portion of an accessory dwelling unit. Proposed structures that are four (4) feet or less from the property line shall be required to provide a record of survey to the City for proof of setbacks and existing property lines.*



Subject: Proposed Amendments to the Chapter 14.14 (Accessory Dwelling Unit) Ordinance
Second Planning Commission Meeting

(4) Mechanical equipment and air conditioning units for accessory dwelling units shall comply with the setbacks identified within Chapter 6.16 of the Noise Control Ordinance.

14.14.050(g)(1-2)-Daylight Plane

A separate diagram was added to show the voluntary setbacks in relationship to the proposed daylight plane provisions

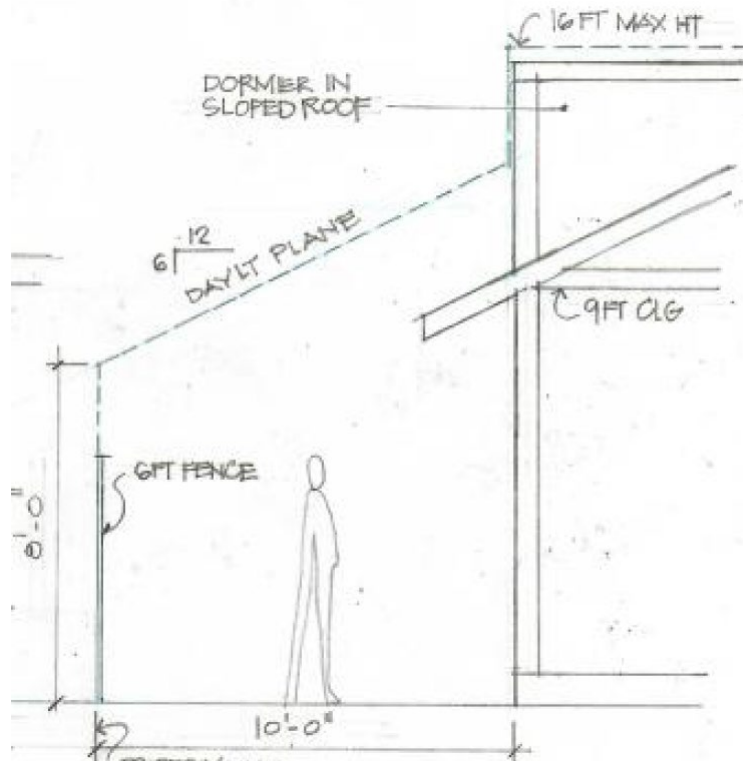

Figure 2-Voluntary Daylight Plane Diagram (Within the Staff Report)

14.14.060 Junior accessory dwelling unit (JADU) standards.

For consistency purposes, the term JADU is used instead of junior accessory dwelling unit in this section of the ordinance per council direction to use consistent terms when drafting the ordinance.



Subject: Proposed Amendments to the Chapter 14.14 (Accessory Dwelling Unit) Ordinance
Second Planning Commission Meeting

14.14.060(a)-This sentence was modified to make it clear that property owners must in in either the house or the JADU.

(a) The owner shall reside in the primary single-family residential dwelling unit or the JADU .

14.14.070 Multi Family Accessory Dwelling Unit (ADU) Standards in Multi Family Zoning Districts)

This title was changed per City Council to make it clear this is for ADUs with existing multifamily housing development projects.

City Council inquired about the legislative history of the provision of AB 881 as they relate to conversion of space within a multifamily development. The intent was to allow conversion of ancillary space only. However, State HCD specifically asked that the City remove verbiage prohibiting conversion of amenities. Additionally, this may be a non-issue because an HOA regulates the common area for townhome or condo project and many have a stake in these amenities. If an apartment amenity is converted, this also could become a contractual issue between a landlord and renter if the lease specifically refers to tenant access to certain amenities.

(b) Portions of existing multi-family dwelling structures that are not used as livable space (including, but not limited to, storage rooms, boiler rooms, passageways, attics, basements, or garages), may be converted for use as accessory dwelling units provided that total number of units must not exceed twenty-five (25) percent of the existing multi-family dwelling units or one (1) unit, whichever is greater.

Section-14.14.080 Voluntary Additional Setback

Edits were made to this section per direction from the City Council and friendly amendments from Planning Commissioner Bressack.

For a detached accessory dwelling unit, the minimum setbacks shall be five feet (5) from the house, and four feet (4) from the side and rear property lines. However, to reduce the privacy impacts to abutting property owners, applicants are encouraged to voluntarily increases the setbacks to be ten (10) feet from the rear and interior property lines. If an applicant provides the ten (10) foot rear and side property line setbacks, the daylight plane provisions will not be enforced for detached accessory dwelling units.



Subject: Proposed Amendments to the Chapter 14.14 (Accessory Dwelling Unit) Ordinance
Second Planning Commission Meeting

Fees

In light of the regional housing crisis, reducing fees for all accessory dwelling units (ADUs) is a concrete step Los Altos could take to demonstrate to the community and the California Department of Housing and Community Development (State HCD) that Los Altos wants to encourage production of these units. This is a positive action step that is in line with new Housing Element Law (AB 671), which encourages cities to incentives the construction of ADUs. The Planning Commission recommended the City reduce fees for a period of one (1) year to incentives these housing units.

14.14.060(k)-Annual Rental Data -Regional Housing Needs Allocation (RHNA) and ADUs

Hillsborough

On May 5, 2020 Los Altos city staff spoke with Liz Ruess, Hillsborough Planning Manager. Hillsborough gets credit for their ADUs at the low and very low income RHNA levels. Every year they send out a survey and property owner self-report the rent for the unit. Liz indicated they get about a 50% response rate for the survey that is sent out.

Half Moon Bay

City staff spoke with Scott Phillips from Half Moon Bay (HMB). HMB, similar to Hillsborough, collects rent data from property owner and then receives credit for their units as being moderate income ADUs.

The approach that Hillsborough and Half Moon Bay have taken to gather information to support meeting their RHNA goal is supported by State HCD per a memo prepared by the 21 Elements Group: <http://21elements.com/documents-mainmenu-3/housing-elements/rhna-5-2014-2022/sites-inventory/655-affordability-of-second-units>

Los Altos should begin a process of collecting ADU data to support meeting our long term RHNA goals. The draft ordinance had a requirement for payment of a fee for annual recertification. The Planning Commission felt that payment of a fee and inspection of the housing unit was a bit “heavy handed,” so that this portion of the ordinance has been modified to say that submittal of rental information shall be done on a voluntary basis. The verbiage related to recertification has been removed.

(e) Annual Rental Data. On an annual basis property owner shall be requested to submit voluntarily rental data for use by the City for the City’s Regional Housing Needs Allocation process.



Subject: Proposed Amendments to the Chapter 14.14 (Accessory Dwelling Unit) Ordinance
Second Planning Commission Meeting

Conclusion

- 1) The Planning Commission and staff recommend that the City Council introduce and waive further reading of the proposed ordinance
- 2) Adopt Zoning Text Amendment 20-0001 and further find the project is exempt from CEQA per Section 21080.17 of the Public Resources Code.
- 3) Amend the Master Fee Schedule to reduce the ADU permit fees for accessory dwelling units for a period of twelve (12) months after final adoption by the City Council of the ordinance.
- 4) Direct staff to prepare an annual ADU rental income survey to be released no later than September 1st of every calendar year, and to collect said data and to report this information to State HCD for purposes of meeting the City's RHNA Housing Element figures.

Los Altos General Plan Conformance

General Plan Land Use Goal 2: Review and amend (as needed) the Zoning Ordinance to provide consistency with new state legislation and court decisions. Consider Zoning Ordinance amendments that implement the use and development of goals, policies and plan objectives for the identified planning areas (Downtown, El Camino Real Corridor, and Foothill Plaza).

Housing Element Policy 4.2: The City will encourage the development of affordable second dwelling units that conform to zoning regulations.

Program 4.2.1 – Facilitate new construction of second dwelling units.

Program 4.2.2-Study the feasibility of reducing minimum lot sizes for second living units.

Options

- 1) Approve Zoning Text Amendment 20-0001

Advantages: Ensure compliance with new state laws.

Disadvantages: Results in less control over accessory dwelling units in Los Altos.

- 2) Direct staff to make further edits to the ordinance and bring the document back for a first reading of the City Council in October



Subject: Proposed Amendments to the Chapter 14.14 (Accessory Dwelling Unit) Ordinance
Second Planning Commission Meeting

Advantages: There is no advantage to denying this ordinance as noncompliance with State law is not a viable position for a municipal agency to be in.

Recommendation

The staff recommends Option 1.

ORDINANCE NO. 2020-___

**AN ORDINANCE OF THE CITY COUNCIL OF THE CITY OF LOS ALTOS
REPEALING AND REPLACING THE ACCESSORY DWELLING UNIT
ORDINANCE AND MAKING FINDINGS OF CEQA EXEMPTION**

WHEREAS, the State Legislature has found that accessory dwelling units are a necessary and valuable form of housing in California; and

WHEREAS, accessory dwelling units help diversify the City's housing stock and help provide rental units that are affordable; and

WHEREAS, accessory dwelling units offer lower cost housing to meet the needs of existing and future residents within existing neighborhoods, while respecting neighborhood character; and

WHEREAS, accessory dwelling units provide housing for family members, students, the elderly, in-home health care providers, the disabled, and others within existing neighborhoods; and

WHEREAS, it is the intent of this ordinance to allow and promote the development of accessory dwelling units; and

WHEREAS, this Ordinance implements Program 4.2.1 and Program 4.2.2 of the City's 2015-2023 Housing Element by facilitating the development of new accessory dwelling units; and

WHEREAS, this Ordinance is exempt from environmental review pursuant to Section 15061 and Section 15301 of the California Environmental Quality Act Guidelines, as amended.

NOW THEREFORE, the City Council of the City of Los Altos does hereby ordain as follows:

SECTION 1. AMENDMENT OF CODE: Chapter 14.14 of Title 14 of the Los Altos Municipal Code is hereby repealed in its entirety and replaced with the new standards and shall read as follows:

Section 14.14.010 Purpose and Intent.

The intent of this chapter is to provide for accessory dwelling units (ADUs) and junior accessory dwelling units (JADUs), collectively known as an accessory dwelling, on lots zoned to allow single-family or multifamily dwelling residential use that include a proposed or existing dwelling. ~~Accessory dwelling units~~ADUs contribute needed housing to the City of Los Altos housing stock and enhance housing opportunities. An ~~accessory dwelling unit~~ADU is considered a residential use that is consistent with the existing general plan and zoning designations for the lot. The ~~accessory dwelling unit~~ADU is not included in calculation of residential density for the purposes of determining general plan conformance.

14.14.020 Definitions.

As used in this section, the following terms mean:

“Accessory dwelling unit” (or “ADU”) means an attached or a detached residential dwelling unit that provides complete independent living facilities and is located on a lot with a proposed or existing ~~primary single family residential dwelling unit~~. It shall include permanent provisions for living, sleeping, eating, cooking, and sanitation on the same parcel as the single-family or multi-family dwelling is or will be situated. An accessory dwelling unit also includes the following:

(A) An efficiency unit, as defined in Section 17958.1 of the Health and Safety Code.

(B) A manufactured home, as defined in Section 18007 of the Health and Safety Code.

~~“Attached aeAccessory dwelling unit, attached|A1”~~ means a residential dwelling unit that is created as a result of internal conversion, addition, or combination thereof made to the primary ~~single-family residential dwelling unit~~ or a multi-family residential development.

~~“Accessory dDwelling uUnit, dDetached.”~~ A detached accessory dwelling unit means an ADU which is constructed as an independent structure, surrounded by open space and on the same lot as the primary single family residential dwelling unit or a multi-family multifamily housing development , except that it can be attached to an accessory structure (e.g., garage|A2).

“Existing,” when referring to an existing principal dwelling, accessory structure, or other building or structure, refers to a building or structure erected prior to the date of adoption of the appropriate building code, or one for which a legal building permit has been issued, as defined in Section 202 of the 2019 California Building Code. An unpermitted building or structure shall not be considered “existing” for purposes of this chapter.

“Multi-family housing” means a dwelling unit or group of dwelling units on one site that contains separate living units for two or more families that may have joined services or facilities or both.

“Junior accessory dwelling unit” (or “junior ADU” or “JADU”) means a unit that is no more than 500 square feet in size, includes an efficiency kitchen consistent with building code standards, is contained entirely within the walls of a single-family residence and may include separate sanitation facilities or may share sanitation facilities with the existing structure or unit.

“Living area” means the interior habitable area of a dwelling unit, including basements and attics, if defined as habitable by the California Residential Code (CRC) but does not include a garage or any accessory structure.

“Nonconforming zoning condition” means a physical improvement on a property that does not conform with current zoning standards.

~~“Primary Ssingle-Ffamily Rresidential Ddwelling Uunit”~~ means a structure containing one or more rooms and one kitchen designed for human occupancy|A3. ~~A dwelling, not attached to~~

any other dwelling which is designed for and occupied by not more than one household and is surrounded by open space or yards.

“Passageway”. The term passageway has the meaning defined by Government Code Section 65852.2, which states: “A pathway that is unobstructed clear to the sky and extends from a street to one entrance of the accessory dwelling unit.”

“Public transit” means a location, including, but not limited to, a bus stop or train station, where the public may access buses, trains, subways, and other forms of transportation that charge set fares, run on fixed routes, and are available to the public.

“Tandem parking” means that two or more automobiles are parked in any location on a lot and lined up behind one another.

14.14.021 Categories of ADUs

Section 14.14.021 is a summary of the various accessory dwelling unit requirements. If this summary of information conflicts with other sections of this Chapter, those sections shall be binding. See Section 14.14.070 for additional requirements that apply to multi-family ADUs.

Design Standards	<u>JADU</u>	Attached ADU (single-family)	Detached ADU (single-family)
Maximum Size (see 14.14.025 for additional details)	500 sq. ft. created from the <u>existing or proposed</u> square footage of the residential structure.	1,200 sq. ft. but no more than 50% of the floor area of an existing or proposed primary <u>single family residential</u> dwelling unit (<u>excluding</u> basement area).	1,200 sq. ft. <u>including</u> basement area).
Maximum Height	NA	The greater of 16 feet or the height of the underlying zoning district	16 feet
Side Setback	NA	4 feet (see exception identified within 14.14.050(f)(2))	4 feet
Rear Setback	NA	4 feet (see exception identified within 14.14.050(f)(2))	4 feet
Kitchen	Cooking appliances can include a hot	Must include at least a sink, a refrigerator of no less than 10 cubic feet, and either a cooktop and an oven, or a range. A food preparation counter	

	plate, or counter-top cooking. A wall installed oven is not required.	and storage cabinets that are of reasonable size in relation to the size of the ADU are also required.
Parking Requirement	None	1 uncovered parking space required. See Section 14.14.050(i)(1-6) for the exceptions to this requirement
Owner Occupancy	Required	Not required
Short Term Rentals	Prohibited	Prohibited
Impact Fees	None	750 sq. ft. or less-no impact fees 751 sq. ft or more-impact fees are proportionate to principal dwelling.
Utility Fees and Connections	None required.	The accessory dwelling may be served by the primary single-family residential dwelling unit -or may have separate utility meters.

14.14.025 Square Footage Chart

For clarity the following chart provides the square footage thresholds for the various forms of accessory dwelling units

Unit Type	Square Footage Limitations
Efficiency Unit	The minimum size of an efficiency unit as defined by the Health and Safety Code shall be 150 square feet.
JADU	The maximum size of a JADU shall be 500 square feet created by the conversion of existing square footage of the dwelling unit. However, up to 150 square feet can be added to the existing structure for purposes of ingress and egress to the JADU. The additional square footage shall count towards the 500 square foot maximum.
<u>Attached accessory dwelling unit</u>	The total floor area for an attached accessory dwelling unit shall not exceed one thousand two hundred (1,200) square feet, excluding the basement areas, and shall not be more than fifty (50) percent of the floor area of the existing or proposed principal residence. Notwithstanding this 50% threshold requirement, an

	<p>ADU of 850 square feet or smaller cannot be denied. More specific requirements are set forth in Section 14.14.050(d).^{A4}</p> <p><u>An attached single family residential accessory dwelling unit shall not exceed eight hundred fifty (850) square feet in floor area for one bedroom units or one thousand two hundred (1,200) square feet for a attached accessory dwelling unit with more than one (1) bedroom. The total floor area for an attached accessory dwelling unit shall exclude –the basement areas, and shall not be more than fifty (50) percent of the floor area of the existing or proposed principal residence. Notwithstanding this 50% threshold requirement, an attached ADU of 850 square feet or smaller cannot be denied. Additional square footage above 850 square feet shall be allowed only if the lot meets the lot coverage and area ratio requirements for the applicable zoning district.</u></p>
<p><u>Detached accessory dwelling unit</u></p>	<p>The total floor area for a detached accessory dwelling unit shall not exceed eight hundred fifty (850) square feet, including basement areas of the detached unit, for any studio or one-bedroom detached accessory dwelling unit or one thousand two hundred (1,200) square feet for any detached accessory dwelling unit with two or more bedrooms.</p> <p><u>A detached single-family residential accessory dwelling unit shall not exceed eight hundred fifty (850) square feet in floor area for one (1) bedroom units, or one thousand two-hundred (1,200) square feet for a detached accessory dwelling unit with more than one (1) bedroom. Additional square footage above 850 square feet shall be allowed only if the lot meets the lot coverage and floor area ratio requirements for the applicable zoning district. For detached accessory dwelling units, garage area is excluded but basement areas are included in the square footage calculation for the accessory dwelling unit.</u></p>
<p>Accessory dwelling unit subject to objective design standards</p>	<p>An ADU between 851-1,200 square feet are subject to a zoning clearance review for objective design standards as identified in Chapter 14.06-Chapter 14.16-24. <u>An ADU may exceed -851 square feet only if the property has not exceeded the floor area ratio allowed for the lot per Chapter 14.06 of the Los Altos Municipal Code</u>^{A5}.</p>

Section 14.14.030 Location Permitted

A. Accessory dwelling unitsADUs may be permitted in the following zones: on lots zoned for multifamily or single-family dwellings.

B. Nothing in this chapter shall be construed to authorize construction of new single-family residences in multiple-family districts where such single-family residential use is not otherwise allowed.

14.14.040 General Requirements.

Notwithstanding any local ordinance regulating the issuance of variances or special use permits, or regulations adopted herein to the contrary, an application ~~for a building permit~~ to construct an ~~accessory dwelling unit (ADU), or junior accessory dwelling unit, or efficiency unit (“accessory dwelling unit”)~~ shall be approved or denied ~~ministerially~~ ministerial without discretionary review or hearing within sixty (60) days from the date the city receives a completed ~~planning~~ application if there is an existing single-family or multifamily structure on the lot. The following requirements apply to all accessory dwellings:

- (a) An ~~accessory dwelling~~ ADU shall not be rented for periods less than thirty (30) days. Short term rentals are prohibited.
- (b) Except as allowed by State law, an ~~accessory dwelling~~ ADU shall not be sold or have its title transferred separately from the ~~primary single family residential structure~~ dwelling unit.
- (c) Deed Restriction. Prior to the issuance of the building permit for the ~~accessory dwelling unit~~ ADU, the owner must record a deed restriction stating that the ~~accessory dwelling unit~~ ADU may not be rented for periods less than thirty (30) days, and that it may not be transferred or sold separate from the primary ~~single-family residential structure~~ dwelling unit.
- (d) The installation of fire sprinklers shall not be required for an ~~accessory dwelling~~ ADU if sprinklers are not required for the primary ~~single-family residential~~ dwelling unit.
- (e) ~~Accessory dwellings~~ ADUs are subject to the design standards and other zoning requirements of the zoning district in which the existing single-family dwelling is located and must be built in accordance with the building code set forth in Title 12 of the Los Altos Municipal Code, except for those design, zoning, and building standards inconsistent with ~~this chapter or with~~ state requirements under California Government Code Section 65852.2.
- (f) An ~~accessory dwelling~~ ADU is not subject to residential accessory structure regulations.
- (g) An ~~accessory dwelling~~ ADU will not be subject to any charges and fees other than planning and building permit fees generally applicable to residential construction in the zone in which the property is located, except as otherwise provided herein.
- (h) Any connection fees and capacity charges that may be required must be assessed in compliance with the provisions of State Government Code Section 65852.2 and 65852.22, ~~and as the sections may be amended over time by the State~~ as amended from time to time.
- (i) The ~~accessory dwelling~~ ADU must contain water, sewer and gas and/or electric utility connections that are in working condition upon its occupancy. The ~~accessory dwelling~~ ADU may be served by the primary ~~single family residential dwelling unit or unit or~~ may have separate utility meters. The accessory dwelling will not be considered a new residential use for the purpose of calculating connection fees or capacity charges for these utilities.

- (j) An ~~accessory dwelling unit~~ADU must have an independent electrical sub-panel, water heating and space heating equipment within the unit or be readily accessible to the occupant on the exterior of the unit.
- (k) Ministerial approval of a permit for creation of an ~~accessory dwelling~~ADU shall not be conditioned on the correction of pre-existing nonconforming zoning conditions.
- (l) A certificate of occupancy for any ~~accessory dwelling~~ADU shall not be issued before the local agency issues a certificate of occupancy for the primary single-family residential dwelling unit.
- (m) If the applicant requests a delay in processing, the 60-day time shall be suspended for the period of the delay.
- (n) A kitchen shall be provided for an ~~accessory dwelling unit~~ADU. A full kitchen requires habitable space used for preparation of food that contains at least a sink, a refrigerator of no less than 10 cubic feet, and either a cooktop and an oven, or a range. A food preparation counter and storage cabinets that are of reasonable size in relation to the size of the ADU are also required.
- (o) ~~A m~~Minimum sill height of 5' (60) inches for windows on the second story within 15' of the property line that face out to the neighbors to mitigate privacy concerns shall be required.
- (p) ~~. A single-family residential accessory dwelling unitADU either attached or detached from the main house must not encroach upon the required front yard area and shall have at least a four-foot setback from the side yard property line.~~

14.14.050 Single-Family Residential ~~Accessory Dwelling Unit~~ADU Standards in Single Family Residential Zoning Districts ~~Zones~~^[A7]

Notwithstanding any other provisions of this chapter to the contrary, a single-family residential ~~accessory dwelling unit~~ADU shall be a permitted as a single-family residential use that shall comply with the following:

- (a) Zoning. A single-family residential ~~accessory dwelling unit~~ADU shall be located on a lot with an existing or proposed primary single-family residential dwelling unit. ~~in a residential or mixed-use zone district.~~
- (b) Number. ~~Only one (1) detached or one (1) attached single-family residential accessory dwelling unit may be permitted on a parcel that contains not more than one existing or proposed single-family residence[A8]. For a lot with a proposed or existing single-family dwelling, one attached or detached, new construction, accessory dwelling unitADU that does not exceed 850 square feet, nor 16 feet in height, and that provides at least four foot side and rear yard setbacks shall be permitted. In the case of a detached accessory dwelling unitADU that does not exceed 850 square feet in size nor 16 feet in height, and that provides at least four foot side and rear setbacks, This the detached accessory dwelling unitADU may be established in addition to a junior accessory dwelling unit (JADU)JADU, as set forth in established pursuant to subsection 14.14.060 One attached or one detached single-family accessory dwelling unit is allowed per lot. Additionally, one (1) Junior Accessory Dwelling~~

~~Unit (JADU) may be allowed within the confines of the existing house, as allowed by Section 14.14.060(b).~~

(c) Relationship to Primary Single-Family Residential Dwelling Unit. A single-family residential ~~accessory dwelling unit~~ADU may be within, attached to, or detached from, the proposed or existing primary single family residential dwelling unit, provided that a single-family residential ~~accessory dwelling unit~~ADU contained within or attached to an existing primary single family residential dwelling unit shall have independent exterior access from the existing residence). A detached single-family residential ~~accessory dwelling unit~~ADU must be located at least five (5) feet from the proposed -or existing primary dwelling per Section 14.14.050(f)(3).

(d) Size.

~~(1) A studio or one (1) bedroom, attached or detached single-family residential accessory dwelling unit shall be permitted, and limited to eight hundred fifty (850) square feet in floor area, garage areas excluded.~~^[A9]

~~(12) A **detached** single-family residential ~~accessory dwelling unit~~ADU shall not exceed eight hundred fifty (850) square feet in floor area for one (1) bedroom units, or one thousand two hundred (1,200) square feet for a detached ~~accessory dwelling unit~~ADU with more than one (1) bedroom^[A10]. Additional square footage above 850 square feet shall be allowed only if the lot meets the lot coverage and floor area ratio requirements for the applicable zoning district. For detached accessory dwelling units, garage area **is excluded** but basement areas **are included** in the square footage calculation for the accessory dwelling unitADU.^{[A11][A12]}~~

~~(23) An **attached** single family residential ~~accessory dwelling unit~~ADU shall not exceed eight hundred fifty (850) square feet in floor area for one bedroom units or one thousand two hundred (1,200) square feet for a attached accessory dwelling unit with more than one (1) bedroom. The total floor area for an **attached** ~~accessory dwelling unit~~ADU shall ~~not exceed one thousand two hundred (1,200) square feet, exclude ing~~ the basement areas, and shall not be more than fifty (50) percent of the floor area of the existing or proposed principal residence. Notwithstanding this 50% threshold requirement, an attached ADU of 850 square feet or smaller cannot be denied. Additional square footage above 850 square feet shall be allowed only if the lot meets the lot coverage and area ratio requirements for the applicable zoning district.~~

~~(34) Internal Attached AADU Conversion. ~~A new detached accessory dwelling unit and an addition to the primary dwelling are limited to 1,200 square feet.~~ There is no size limitation on an ~~accessory dwelling unit~~ADU that is created exclusively by converting space within the existing primary single family dwelling unit or accessory ~~structure~~^[A13]. ~~—If a homeowner converts a portion of the primary single family residential dwelling unit for an attached accessory dwelling unitADU, nothing herein shall prevent the homeowner from replacing the square footage lost, up to up to 850sf above FAR limits, subject to the applicable design rules for the specific zoning district.~~^[A14]~~

~~(4) The accessory dwelling unit ADU may include an expansion of not more than 150 square feet beyond the same physical dimensions as the existing accessory structure to accommodate ingress and egress.~~

~~(5) If a homeowner converts a portion of the primary single family residential dwelling unit for an attached accessory dwelling unit, nothing herein shall prevent the homeowner from replacing the square footage lost, up to up to 850sf above FAR limits, subject to the applicable design rules for the specific zoning district. ^{A15}~~

(e) Height.

(1) The maximum height for a detached single-family residential ~~accessory dwelling unit~~ ADU shall be one-story and sixteen (16) feet.

(2) Attached single-family residential ~~accessory dwelling units~~ ADUs shall have a maximum height of equal to the greater of (i) sixteen (16) feet, or (ii) the height limit established for the primary ~~single family residential dwelling unit~~ structure pursuant to applicable zoning.

(f) Setbacks. A single-family residential ~~accessory dwelling unit~~ ADU is subject to the design criteria and zoning requirements of the district in which the existing single-family dwelling is located and as follows:

(1) ~~An attached or detached~~ single-family residential ~~accessory dwelling unit~~ ADU ~~either attached or detached from the main house~~ must not encroach upon the required front ~~lot line~~ yard area, and shall have at least ~~a four (4) foot setbacks at the rear and side yards~~ ~~is as the minimum per state law.~~ ~~from the side yard property line.~~ ~~Four feet setbacks is the maximum the City can recommend per state law, but a~~ applicants are encouraged to ~~voluntarily~~ comply ~~voluntarily~~ with the setbacks identified within 14.14.080 of ten ~~(10)~~ feet from the side and rear property lines ~~so as to reduce privacy impacts.~~ ~~An accessory dwelling unit ADU that provides such ten (10) foot setback shall and in doing so so be removed from daylight plane restrictions.~~ ^{A16}

(2) A setback of four (4) feet from the interior side and rear lot lines shall be required for a newly constructed, detached or attached single-family residential ~~accessory dwelling unit~~ ADU. ~~No setback shall be required for an existing living area or accessory structure or a structure constructed in the same location and to the same dimensions and within the same footprint as an existing structure that is converted to an accessory dwelling unit ADU or to a portion of an accessory dwelling unit ADU. If a structure is built in the same location, and the with the same dimensions and footprint and is not less than 4 feet from the property lines, the City is required by state law to grant this setback.~~ Proposed structures that are four (4) feet or less from the property line shall be required to provide a record of survey to the City for proof of setbacks and existing property lines. ^{A17}

(3) —The separation from the principal dwelling and any other accessory structure on the lot shall be at least five (5) feet unless implementation of this requirement would prohibit the construction of an 850 square foot detached ~~accessory dwelling unit~~ ADU, in which case this

requirement shall be waived provided the ADU complies with California Building Code (CBC) requirements for separation.

~~(4) No additional zoning setback is required for conversion of an existing permitted accessory structure, living area, or garage space, or conversion of a structure that is constructed in the same location and to the same dimensions as the existing footprint footprint structure.~~

(45) Mechanical equipment and air conditioning units for accessory dwelling units shall comply with the setbacks identified within Chapter 6.16 of the Noise Control Ordinance A18.

(g) Detached ~~Accessory Dwelling Unit~~ADU Daylight Plane

(1) No portion of an attached or detached ~~accessory dwelling unit~~ADU shall extend above or beyond a daylight plane as follows:

(2) The daylight plane starts at a height of eight feet at the property line and proceeds inward at a 6:12 slope. At ten feet from the property line the structure can increase in height to sixteen (16) feet. All appurtenances, including chimneys, vents and antennas, shall be within the daylight plane. The daylight plane is not applied to a side or rear property line when it abuts a public alley or public street. However, the ~~accessory dwelling unit (ADU)~~ADU daylight plane shall not be enforced if it prohibits the development of an 850 square foot ADU which is required by state law. If an applicant provides the voluntary setbacks identified in 14.14.080 of ten feet for the side and rear property lines, the daylight plane provisions will not apply to the structural elements of the ~~accessory dwelling unit~~ADU.

(3) Daylight plane shall not be enforced for an ADU if the structure abuts a city street or alleyway in the rear of the property.

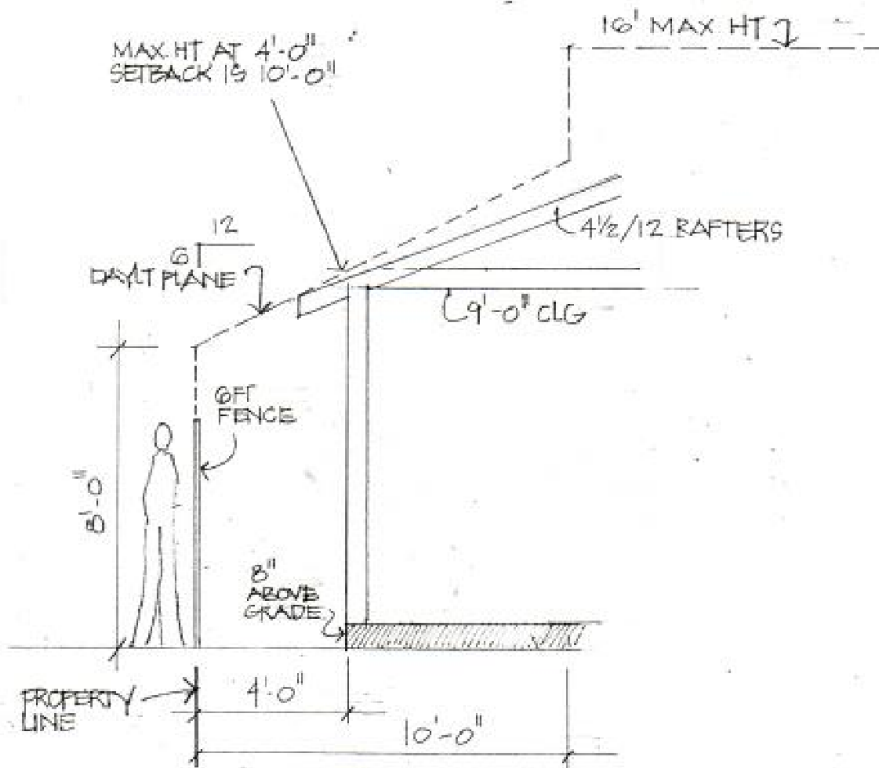

Figure 1-Standard Daylight Plane Diagram

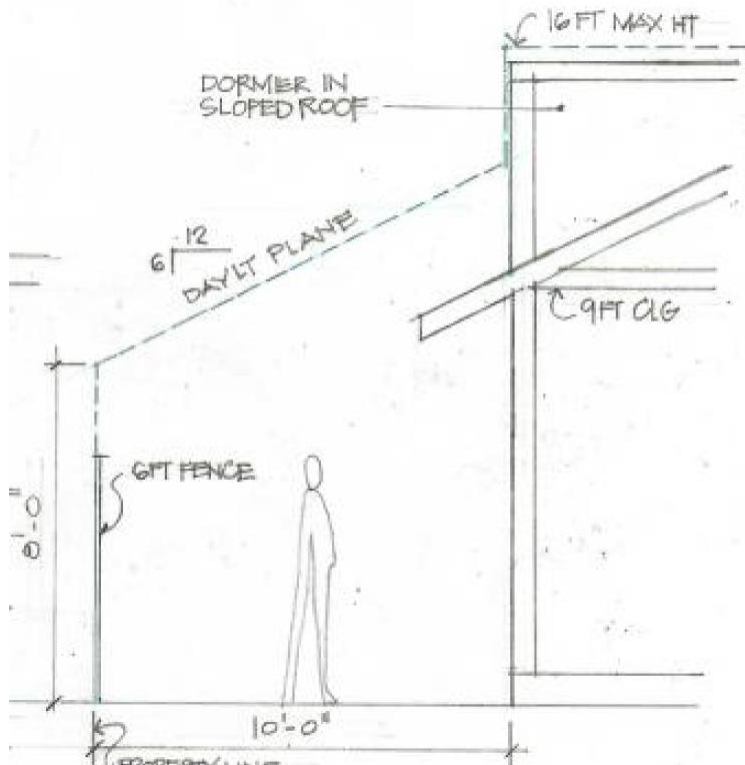

Figure 2-Voluntary Daylight Plane [Diagram](#)^[A19]

(h) A single-family residential [accessory dwelling unit](#) ADU must be built in accordance with the building code set forth in Title 12, except that any design, zoning, and building standards inconsistent with state requirements under California Government Code Section 65852.2 shall not apply.

(i) Parking. One (1) additional uncovered parking space of nine feet by eighteen feet (9X18) shall be required for a newly constructed single-family residential [accessory dwelling unit](#) ADU, which may be located within the front setback, in tandem and in an existing driveway including within an interior side yard setback area, unless a specific finding is made that such parking is not feasible due to specific site, topographical or fire and life safety. Notwithstanding the above, a parking stall will not be required for a residential [accessory dwelling unit](#) ADU that meets any of the following criteria:

(1) The single-family residential [accessory dwelling unit](#) ADU is created as a result of the conversion of existing area of the single-family residence or existing permitted residential accessory structure.

(2) An existing garage, carport or parking structure is converted or demolished to accommodate a single-family residential [accessory dwelling unit](#) ADU in the same location.

(3) The single-family residential [accessory dwelling unit](#) ADU is within one-half (1/2) mile walking distance of a public transit station, such as a bus stop or train station.

- (4) The property is within an architecturally and historically significant historic district.
- (5) On-street parking permits are required in the area but not offered to the occupant of the residential ~~accessory dwelling unit~~ADU.
- (6) A vehicle share site is located within one (1) block of the single-family residential ~~accessory dwelling unit~~ADU.
- (j) Design Standards. Architectural review of attached or detached single-family residential ~~accessory dwelling units~~ADUs over 851 square feet or greater will be limited to the following:
- (1) Notwithstanding any other provision of this code, a zoning clearance letter shall be issued for ~~accessory dwelling units~~ADUs and shall be reviewed by the director of community development or their designee for compliance with objective design standards as identified within Chapter 14.06(Single Family Zoning Districts) or Chapters 14.16-14.24 (Multi Family Zoning Districts). The permit shall be considered ministerial without discretionary review within the time frames required by Section 65852.2 of the Government Code;
- (2) In those instances where an applicant seeks permission to deviate from the standards, a variance shall be filed in accordance with 14.76.070.
- ~~(3)~~ If the permit application to create an ~~accessory dwelling unit~~ADU or a ~~junior accessory dwelling unit~~JADU —is submitted with a permit application to create a new single-family dwelling on the lot, the City may delay acting on the permit application for the ~~accessory dwelling unit~~ADU or the ~~JADU junior accessory dwelling unit~~ until the permitting agency acts on the permit application to create the new single-family dwelling, but the application to create the ~~accessory dwelling unit~~ADU or ~~JADU junior accessory dwelling unit~~ shall be considered without discretionary review or hearing. If the applicant requests a delay, the 60-day time period shall be suspended for the period of the delay.
- ~~(4)~~ The architectural features, window styles, roof slopes, exterior materials, colors, appearance, and design of the single-family residential ~~accessory dwelling unit~~ADU must be compatible with the existing single-family dwelling.
- ~~(5)~~ Minimum sill height of 5' (60) inches for windows on the second story within 15' of the property line that face out to the neighbors to try to mitigate privacy concerns shall be required.
- ~~(6)~~ A new single-family residential ~~accessory dwelling unit~~ADU located within a historic site or neighborhood combining district will be subject to ministerial review for compliance with the design review criteria set forth in section Chapter 12.44 of the Los Altos Municipal Code and must be consistent with the Secretary of Interior's Standards for the Treatment of Historic Properties.
- ~~(7)~~ Outside stairways serving a second story single-family residential ~~accessory dwelling unit~~ADU shall not be constructed on any building elevation facing a public street.
- ~~(8)~~ No passageway will be required in conjunction with the construction of any single-family residential ~~accessory dwelling unit~~ADU.

(k) —Streamlined Approval of Accessory Dwelling Units. Notwithstanding the restrictions above, a building permit application for a detached, single-family residential ~~accessory dwelling unit~~ADU within a residential or mixed-use zone must be a ministerial approved if it is:

(1) Setback at least four (4) feet from the interior side and rear lot lines. Four feet setbacks is the maximum the City can recommend per state law, but applicants are encouraged to voluntarily comply with the setbacks identified within 14.14.080 of ten (10) feet from the side and rear property lines so as to reduce privacy impacts.

(2) No larger than eight hundred and fifty (850) square feet in floor area; and

(3) No taller than sixteen (16) feet in height.

(l) Annual Rental Data. On an ~~annual basis property owners~~annual basis property owner shall ~~be requested to submit~~ voluntarily ~~submit~~ rental data for use by the City for the Regional Housing Needs Allocation process.

14.14.060 ~~Junior accessory dwelling unit (JADU)~~JADU standards.

Notwithstanding any other provisions in this Article or of this chapter to the contrary, ~~a~~a ~~JADU junior accessory dwelling unit~~ shall be permitted and comply with the following:

(a) ~~Owner occupancy of the property shall be required for junior accessory dwelling units or the main dwelling unit.~~ The owner ~~may shall~~ reside in the primary ~~single--family residential dwelling unit ee or the~~ JADU junior accessory dwelling unit ~~or separate residential accessory dwelling unit constructed on the property in compliance with this Article.~~

(b) One (1) ~~junior accessory dwelling unit~~JADU -may be permitted per residential lot zoned for a single-family residential use, provided that the lot has not more than one (1) existing or proposed single-family residence. A single-family residential lot ~~is allowed to~~may have both one

(1) ~~junior accessory dwelling unit (JADU)~~ and one detached accessory dwelling unit.

(c) The unit must be constructed within the existing walls of a single-family dwelling except that an expansion of 150 square feet beyond the existing physical dimensions of the primary single family residential dwelling unit may be permitted to accommodate required ingress and egress.

(d) The square footage of the unit shall be at least the minimum size (150 square feet) required for an efficiency unit, up to a maximum size of five hundred (500) square feet in floor area, and must include one bedroom or studio sleeping area.

(e) A separate entrance from the unit to the exterior of the residence, and an interior connection to the main living area may be provided. A second interior doorway for sound attenuation may also be permitted.

(g) At least an efficiency kitchen must be provided in the unit which shall include ~~all of~~all the following:

(1) A cooking facility with appliances. Appliances can include hot plate, or counter-top cooking. A property owner does not need to have a wall installed oven or stove to qualify for a cooking appliance.

(2) A food preparation counter and storage cabinets that are of reasonable size in relation to the size of the ~~junior accessory dwelling unit.~~ JADU.

(h) The unit may include separate bathroom facilities or may share bathroom facilities contained within the primary ~~single-family~~ single-family residential dwelling unit.

(i) No separate utility connection, connection fee or capacity charge, or parking space shall be required for a ~~junior accessory dwelling unit.~~ JADU.

(j) a deed restriction shall be required for ~~junior accessory dwelling units~~ JADU and must include the following stipulations:

(1) prohibition on the sale of the JADU separate from the sale of the ~~single-family primary~~ single family residential dwelling unit. ~~residence~~

(2) if a JADU is rented, the unit shall not be rented for a period of less than thirty (30) consecutive days

(3) owner occupancy is required for the JADU or the main house, unless the owner is another government agency, land trust or housing organization as allowed by State Law.

(k) Annual Rental Data. On an annual basis property owner shall be requested to submit voluntarily ~~submit~~ rental data for use by the City for the Regional Housing Needs Allocation process.

14.14.070 ~~Multi Family Accessory Dwelling Unit (ADU) Standards in Multi Family Zoning [Districts]~~^[A20]^[A21] ~~- family accessory dwelling unit Standards.~~

Notwithstanding any other provisions of this chapter to the contrary, multi-family ~~accessory dwelling unit~~ ADUs shall be permitted and comply with the following:

(a) The type of ADUs described in the single-family portion of the ordinance may ~~also~~ be built on a multifamily site, subject to the requirements of this section ~~if so desired.~~

(b) Portions of existing multi-family dwelling structures that are not used as livable space (including, but not limited to, storage rooms, boiler rooms, passageways, attics, basements, or garages), may be converted for use as ~~accessory dwelling units~~ ADUs provided that total number of units must not exceed twenty-five (25) percent of the existing multi-family dwelling units or one (1) unit, whichever is greater^[A22].

(c) An owner may also construct up to a maximum of two detached ~~accessory dwelling units~~ ADUs on a lot that has an existing multifamily dwelling, subject to a height limit of sixteen (16) feet and at least four (4) foot rear yard and side setbacks. If there are inconsistencies between this Chapter and other provisions of the Los Altos municipal code, this Chapter shall prevail over those other provisions.

(d) ~~Accessory dwelling units~~ADUs in multi-family zone districts shall comply with Government Code Section 65852.2.

(e) Annual Rental Data. On an annual basis property owner shall ~~be requested to submit~~ voluntarily ~~submit~~ rental data for use by the City for the City's Regional Housing Needs Allocation process.

14.14.080 Voluntary Additional Setback

For a detached accessory dwelling unit, the minimum setbacks shall be five feet (5) from the ~~primary residence~~, and four feet (4) from the side ~~yard~~ and rear ~~yard setbacks~~ ~~property lines~~. However, ~~so as to~~ ~~to~~ reduce the privacy impacts to abutting property owners, applicants are encouraged to voluntarily increase the setbacks to be ten (10) feet from the rear ~~yard and interior property lines~~ ~~and ten feet (10) from the interior side yard~~. If an applicant provides the ten (10) foot rear ~~and side property line setbacks~~ ~~yard and interior side yard setback~~ the daylight plane provisions will not be enforced for detached accessory dwelling units[A23].

14.14.090 Voluntary ADU Rental Income Survey

City staff are directed to send out an annual ADU rental income survey to be released no later than September 1st of every calendar year. The property owner can voluntarily share the rental income for the unit with the City for purposes of Los Altos meeting its Regional Housing Needs Allocation (RHNA) Housing Element figures.

SECTION 2. CONSTITUTIONALITY. If any section, subsection, sentence, clause or phrase of this code is for any reason held to be invalid or unconstitutional, such decision shall not affect the validity of the remaining portions of this code.

SECTION 3. CEQA. The City Council finds the adoption of this ordinance to be statutorily exempt from the requirements of the California Environmental Quality Act (CEQA) pursuant to Section 21080.17 of the Public Resources Code because it is an ordinance regarding second units in single-family and multifamily residential zones to implement the provisions of Government Code Section 65852.2.

SECTION 4. PUBLICATION. This ordinance shall be published as provided in Government Code section 36933. Within 15 days of the passage of this ordinance, the City Clerk shall cause the full text of the ordinance, with the names of those City Council members voting for and against the ordinance, to be published in an adjudicated newspaper. In lieu of publishing the full text of the ordinance, the City Clerk, if so directed by the City Attorney and within 15 days, shall cause a summary of the ordinance, prepared by the City Attorney and with the names of the City Council members voting for and against the ordinance, to be published in an adjudicated newspaper, and shall post in the office of the City Clerk a certified copy of the full text of the ordinance, along with the names of those City Council members voting for and against the ordinance. The publication of a summary of the ordinance in lieu of the full text of the ordinance is authorized only where the requirements of Government Code Section 36933(c)(1) are met.

SECTION 5. EFFECTIVE DATE. This ordinance shall be effective upon the commencement of the thirty-first day following the adoption date.

SECTION 6. TRANSMISSION TO HCD. The City Clerk shall send a certified copy of this ordinance to the Department of Housing and Community Development (HCD) within sixty (60) days after adoption, as required by state law.

The foregoing ordinance was duly and properly introduced at a regular meeting of the City Council of the City of Los Altos held on _____, 2020 and was thereafter, at a regular meeting held on _____, 2020 passed and adopted by the following vote:

AYES:
NOES:
ABSENT:
ABSTAIN:

Janis C. Pepper, MAYOR

Attest:

Jon Maginot, CMC, CITY CLERK

ORDINANCE NO. 2020- 473

**AN ORDINANCE OF THE CITY COUNCIL OF THE CITY OF LOS ALTOS
REPEALING AND REPLACING THE ACCESSORY DWELLING UNIT
ORDINANCE AND MAKING FINDINGS OF CEQA EXEMPTION**

WHEREAS, the State Legislature has found that accessory dwelling units are a necessary and valuable form of housing in California; and

WHEREAS, accessory dwelling units help diversify the City’s housing stock and help provide rental units that are affordable; and

WHEREAS, accessory dwelling units offer lower cost housing to meet the needs of existing and future residents within existing neighborhoods, while respecting neighborhood character; and

WHEREAS, accessory dwelling units provide housing for family members, students, the elderly, in-home health care providers, the disabled, and others within existing neighborhoods; and

WHEREAS, it is the intent of this ordinance to allow and promote the development of accessory dwelling units; and

WHEREAS, this Ordinance implements Program 4.2.1 and Program 4.2.2 of the City’s 2015-2023 Housing Element by facilitating the development of new accessory dwelling units; and

WHEREAS, this Ordinance is exempt from environmental review pursuant to Section 15061 and Section 15301 of the California Environmental Quality Act Guidelines, as amended.

NOW THEREFORE, the City Council of the City of Los Altos does hereby ordain as follows:

SECTION 1. AMENDMENT OF CODE: Chapter 14.14 of Title 14 of the Los Altos Municipal Code is hereby repealed in its entirety and replaced with the new standards and shall read as follows:

Section 14.14.010 Purpose and Intent.

The intent of this chapter is to provide for accessory dwelling units (ADUs) and junior accessory dwelling units (JADUs), collectively known as an accessory dwelling, on lots zoned to allow single-family or multifamily dwelling residential use that include a proposed or existing dwelling. ADUs contribute needed housing to the City of Los Altos housing stock and enhance housing opportunities. An ADU is considered a residential use that is consistent with the existing general plan and zoning designations for the lot. The ADU is not included in calculation of residential density for the purposes of determining general plan conformance.

14.14.020 Definitions.

As used in this section, the following terms mean:

“Accessory dwelling unit” (or “ADU”) means an attached or a detached residential dwelling unit that provides complete independent living facilities and is located on a lot with a proposed or existing residential dwelling unit. It shall include permanent provisions for living, sleeping, eating, cooking, and sanitation on the same parcel as the single-family or multi-family dwelling is or will be situated. An accessory dwelling unit also includes the following:

(A) An efficiency unit, as defined in Section 17958.1 of the Health and Safety Code.

(B) A manufactured home, as defined in Section 18007 of the Health and Safety Code.

“Accessory dwelling unit, attached” means a residential dwelling unit that is created as a result of internal conversion, addition, or combination thereof made to the primary single-family residential dwelling unit or a multi-family residential development.

“Accessory dwelling unit, detached.” A detached accessory dwelling unit means an ADU which is constructed as an independent structure, surrounded by open space and on the same lot as the primary single family residential dwelling unit or a multifamily housing development , except that it can be attached to an accessory structure (e.g., garage).

“Existing,” when referring to an existing principal dwelling, accessory structure, or other building or structure, refers to a building or structure erected prior to the date of adoption of the appropriate building code, or one for which a legal building permit has been issued, as defined in Section 202 of the 2019 California Building Code. An unpermitted building or structure shall not be considered “existing” for purposes of this chapter.

“Multi-family housing” means a dwelling unit or group of dwelling units on one site that contains separate living units for two or more families that may have joined services or facilities or both.

“Junior accessory dwelling unit” (or “junior ADU” or “JADU”) means a unit that is no more than 500 square feet in size, includes an efficiency kitchen consistent with building code standards, is contained entirely within the walls of a single-family residence and may include separate sanitation facilities or may share sanitation facilities with the existing structure or unit.

“Living area” means the interior habitable area of a dwelling unit, including basements and attics, if defined as habitable by the California Residential Code (CRC) but does not include a garage or any accessory structure.

“Nonconforming zoning condition” means a physical improvement on a property that does not conform with current zoning standards.

“Primary single-family residential dwelling unit” A dwelling, not attached to any other dwelling which is designed for and occupied by not more than one household and is surrounded by open space or yards.

“Passageway”. The term passageway has the meaning defined by Government Code Section 65852.2, which states: “A pathway that is unobstructed clear to the sky and extends from a street to one entrance of the accessory dwelling unit.”

“Public transit” means a location, including, but not limited to, a bus stop or train station, where the public may access buses, trains, subways, and other forms of transportation that charge set fares, run on fixed routes, and are available to the public.

“Tandem parking” means that two or more automobiles are parked in any location on a lot and lined up behind one another.

14.14.021 Categories of ADUs

Section 14.14.021 is a summary of the various accessory dwelling unit requirements. If this summary of information conflicts with other sections of this Chapter, those sections shall be binding. See Section 14.14.070 for additional requirements that apply to multi-family ADUs.

Design Standards	JADU	Attached ADU (single-family)	Detached ADU (single-family)
Maximum Size (see 14.14.025 for additional details)	500 sq. ft. created from the <u>existing or proposed</u> square footage of the residential structure.	1,200 sq. ft. but no more than 50% of the floor area of an existing or proposed primary single family residential dwelling unit (<u>excluding</u> basement area).	1,200 sq. ft. <u>including</u> basement area).
Maximum Height	NA	The greater of 16 feet or the height of the underlying zoning district	16 feet
Side Setback	NA	4 feet (see exception identified within 14.14.050(f)(2))	4 feet
Rear Setback	NA	4 feet (see exception identified within 14.14.050(f)(2))	4 feet
Kitchen	Cooking appliances can include a hot plate, or counter-top cooking. A wall installed	Must include at least a sink, a refrigerator of no less than 10 cubic feet, and either a cooktop and an oven, or a range. A food preparation counter and storage cabinets that are of reasonable size in relation to the size of the ADU are also required.	

	oven is not required.	
Parking Requirement	None	1 uncovered parking space required. See Section 14.14.050(i)(1-6) for the exceptions to this requirement
Owner Occupancy	Required	Not required
Short Term Rentals	Prohibited	Prohibited
Impact Fees	None	750 sq. ft. or less-no impact fees 751 sq. ft or more-impact fees are proportionate to principal dwelling.
Utility Fees and Connections	None required.	The accessory dwelling may be served by the primary single-family residential dwelling unit or may have separate utility meters.

14.14.025 Square Footage Chart

For clarity the following chart provides the square footage thresholds for the various forms of accessory dwelling units

Unit Type	Square Footage Limitations
Efficiency Unit	The minimum size of an efficiency unit as defined by the Health and Safety Code shall be 150 square feet.
JADU	The maximum size of a JADU shall be 500 square feet created by the conversion of existing square footage of the dwelling unit. However, up to 150 square feet can be added to the existing structure for purposes of ingress and egress to the JADU. The additional square footage shall count towards the 500 square foot maximum.
<u>Attached accessory dwelling unit</u>	An attached single family residential accessory dwelling unit shall not exceed eight hundred fifty (850) square feet in floor area for one bedroom units or one thousand two hundred (1,200) square feet for a attached accessory dwelling unit with more than one (1) bedroom. The total floor area for an attached accessory dwelling unit shall exclude the basement areas, and shall not be more than fifty (50) percent of the floor area of the existing or proposed principal residence. Notwithstanding this 50% threshold requirement, an attached ADU of 850 square feet or smaller cannot be denied. Additional square footage above 850 square feet

	shall be allowed only if the lot meets the lot coverage and area ratio requirements for the applicable zoning district.
<u>Detached accessory dwelling unit</u>	A detached single-family residential accessory dwelling unit shall not exceed eight hundred fifty (850) square feet in floor area for one (1) bedroom units, or one thousand two-hundred (1,200) square feet for a detached accessory dwelling unit with more than one (1) bedroom. Additional square footage above 850 square feet shall be allowed only if the lot meets the lot coverage and floor area ratio requirements for the applicable zoning district. For detached accessory dwelling units, garage area is excluded but basement areas are included in the square footage calculation for the accessory dwelling unit.
Accessory dwelling unit subject to objective design standards	An ADU between 851-1,200 square feet are subject to a zoning clearance review for objective design standards as identified in Chapter 14.06-Chapter 14.16-24. An ADU may exceed 851 square feet only if the property has not exceeded the floor area ratio allowed for the lot per Chapter 14.06 of the Los Altos Municipal Code.

Section 14.14.030 Location Permitted

A. ADUs may be permitted in the following zones: on lots zoned for multifamily or single-family dwellings.

B. Nothing in this chapter shall be construed to authorize construction of new single-family residences in multiple-family districts where such single-family residential use is not otherwise allowed.

14.14.040 General Requirements.

Notwithstanding any local ordinance regulating the issuance of variances or special use permits, or regulations adopted herein to the contrary, an application to construct an ADU, shall be approved or denied ministerial without discretionary review or hearing within sixty (60) days from the date the city receives a completed planning application if there is an existing single-family or multifamily structure on the lot. The following requirements apply to all accessory dwellings:

- (a) An ADU shall not be rented for periods less than thirty (30) days. Short term rentals are prohibited.
- (b) Except as allowed by State law, an ADU shall not be sold or have its title transferred separately from the primary single family residential dwelling unit.
- (c) Deed Restriction. Prior to the issuance of the building permit for the ADU, the owner must record a deed restriction stating that the ADU may not be rented for periods less than

thirty (30) days, and that it may not be transferred or sold separate from the primary single-family residential dwelling unit.

(d) The installation of fire sprinklers shall not be required for an ADU if sprinklers are not required for the primary single-family residential dwelling unit.

(e) ADUs are subject to the design standards and other zoning requirements of the zoning district in which the existing single-family dwelling is located and must be built in accordance with the building code set forth in Title 12 of the Los Altos Municipal Code, except for those design, zoning, and building standards inconsistent with this chapter or with state requirements under California Government Code Section 65852.2.

(f) An ADU is not subject to residential accessory structure regulations.

(g) An ADU will not be subject to any charges and fees other than planning and building permit fees generally applicable to residential construction in the zone in which the property is located, except as otherwise provided herein.

(h) Any connection fees and capacity charges that may be required must be assessed in compliance with the provisions of State Government Code Section 65852.2 and 65852.22, as amended from time to time.

(i) The ADU must contain water, sewer and gas and/or electric utility connections that are in working condition upon its occupancy. The ADU may be served by the primary single family residential dwelling unit or may have separate utility meters. The accessory dwelling will not be considered a new residential use for the purpose of calculating connection fees or capacity charges for these utilities.

(j) An ADU must have an independent electrical sub-panel, water heating and space heating equipment within the unit or be readily accessible to the occupant on the exterior of the unit.

(k) Ministerial approval of a permit for creation of an ADU shall not be conditioned on the correction of pre-existing nonconforming zoning conditions.

(l) A certificate of occupancy for any ADU shall not be issued before the local agency issues a certificate of occupancy for the primary single-family residential dwelling unit.

(m) If the applicant requests a delay in processing, the 60-day time shall be suspended for the period of the delay.

(n) A kitchen shall be provided for an ADU. A full kitchen requires habitable space used for preparation of food that contains at least a sink, a refrigerator of no less than 10 cubic feet, and either a cooktop and an oven, or a range. A food preparation counter and storage cabinets that are of reasonable size in relation to the size of the ADU are also required.

(o) A minimum sill height of 5' (60) inches for windows on the second story within 15' of the property line that face out to the neighbors to mitigate privacy concerns shall be required.

(p). A single-family residential ADU either attached or detached from the main house must not encroach upon the required front yard area and shall have at least a four-foot setback from the side yard property line.

14.14.050 Single-Family Residential ADU Standards in Single Family Residential Zoning Districts

Notwithstanding any other provisions of this chapter to the contrary, a single-family residential ADU shall be a permitted as a single-family residential use that shall comply with the following:

(a) Zoning. A single-family residential ADU shall be located on a lot with an existing or proposed primary single-family residential dwelling unit.

(b) Number. For a lot with a proposed or existing single-family dwelling, one attached or detached, new construction ADU shall be permitted. In the case of a detached ADU that does not exceed 850 square feet in size nor 16 feet in height, and that provides at least four foot side and rear setbacks, the detached ADU may be established in addition to a JADU, as set forth in section 14.14.060

(c) Relationship to Primary Single-Family Residential Dwelling Unit. A single-family residential ADU may be within, attached to, or detached from, the proposed or existing primary single family residential dwelling unit, provided that a single-family residential ADU contained within or attached to an existing primary single family residential dwelling unit shall have independent exterior access from the existing residence. A detached single-family residential ADU must be located at least five (5) feet from the proposed or existing primary dwelling per Section 14.14.050(f)(3).

(d) Size.

(1) A **detached** single-family residential ADU shall not exceed eight hundred fifty (850) square feet in floor area for one (1) bedroom units, or one thousand two-hundred (1,200) square feet for a detached ADU with more than one (1) bedroom. Additional square footage above 850 square feet shall be allowed only if the lot meets the lot coverage and floor area ratio requirements for the applicable zoning district. For detached accessory dwelling units, garage area **is excluded** but basement areas **are included** in the square footage calculation for the ADU.

(2) An **attached** single family residential ADU shall not exceed eight hundred fifty (850) square feet in floor area for one bedroom units or one thousand two hundred (1,200) square feet for a attached accessory dwelling unit with more than one (1) bedroom. The total floor area for an **attached** ADU shall **exclude** the basement areas, and shall not be more than fifty (50) percent of the floor area of the existing or proposed principal residence. Notwithstanding this 50% threshold requirement, an attached ADU of 850 square feet or smaller cannot be denied. Additional square footage above 850 square feet shall be allowed only if the lot meets the lot coverage and area ratio requirements for the applicable zoning district.

(3) Internal Attached ADU Conversion. - There is no size limitation on an ADU that is created exclusively by converting space within the existing primary single family dwelling unit or

accessory structure. If a homeowner converts a portion of the primary single family residential dwelling unit for an attached ADU, nothing herein shall prevent the homeowner from replacing the square footage lost, up to up to 850sf above FAR limits, subject to the applicable design rules for the specific zoning district.

(e) Height.

(1) The maximum height for a detached single-family residential ADU shall be one-story and sixteen (16) feet.

(2) Attached single-family residential ADUs shall have a maximum height of equal to the greater of (i) sixteen (16) feet, or (ii) the height limit established for the primary single family residential dwelling unit structure pursuant to applicable zoning.

(f) Setbacks. A single-family residential ADU is subject to the design criteria and zoning requirements of the district in which the existing single-family dwelling is located and as follows:

(1) An attached or detached single-family residential ADU must not encroach upon the required front yard area, and shall have at least four (4) foot setbacks at the rear and side yards per state law. Applicants are encouraged to comply voluntarily with the setbacks identified within 14.14.080 of ten (10) feet from the side and rear property lines to reduce privacy impacts. An ADU that provides such ten (10) foot setback shall be removed from daylight plane restrictions

(2) A setback of four (4) feet from the interior side and rear lot lines shall be required for a newly constructed, detached or attached single-family residential ADU. No setback shall be required for an existing living area or accessory structure or a structure constructed in the same location and to the same dimensions and within the same footprint as an existing structure that is converted to an ADU or to a portion of an ADU. Proposed structures that are four (4) feet or less from the property line shall be required to provide a record of survey to the City for proof of setbacks and existing property lines.

(3) The separation from the principal dwelling and any other accessory structure on the lot shall be at least five (5) feet unless implementation of this requirement would prohibit the construction of an 850 square foot detached ADU, in which case this requirement shall be waived provided the ADU complies with California Building Code (CBC) requirements for separation.

(4) Mechanical equipment and air conditioning units for accessory dwelling units shall comply with the setbacks identified within Chapter 6.16 of the Noise Control Ordinance.

(g) Detached ADU Daylight Plane

(1) No portion of an attached or detached ADU shall extend above or beyond a daylight plane as follows:

(2) The daylight plane starts at a height of eight feet at the property line and proceeds inward at a 6:12 slope. At ten feet from the property line the structure can increase in

height to sixteen (16) feet. All appurtenances, including chimneys, vents and antennas, shall be within the daylight plane. The daylight plane is not applied to a side or rear property line when it abuts a public alley or public street. However, the ADU daylight plane shall not be enforced if it prohibits the development of an 850 square foot ADU which is required by state law. If an applicant provides the voluntary setbacks identified in 14.14.080 of ten feet for the side and rear property lines, the daylight plane provisions will not apply to the structural elements of the ADU.

- (3) Daylight plane shall not be enforced for an ADU if the structure abuts a city street or alleyway in the rear of the property.

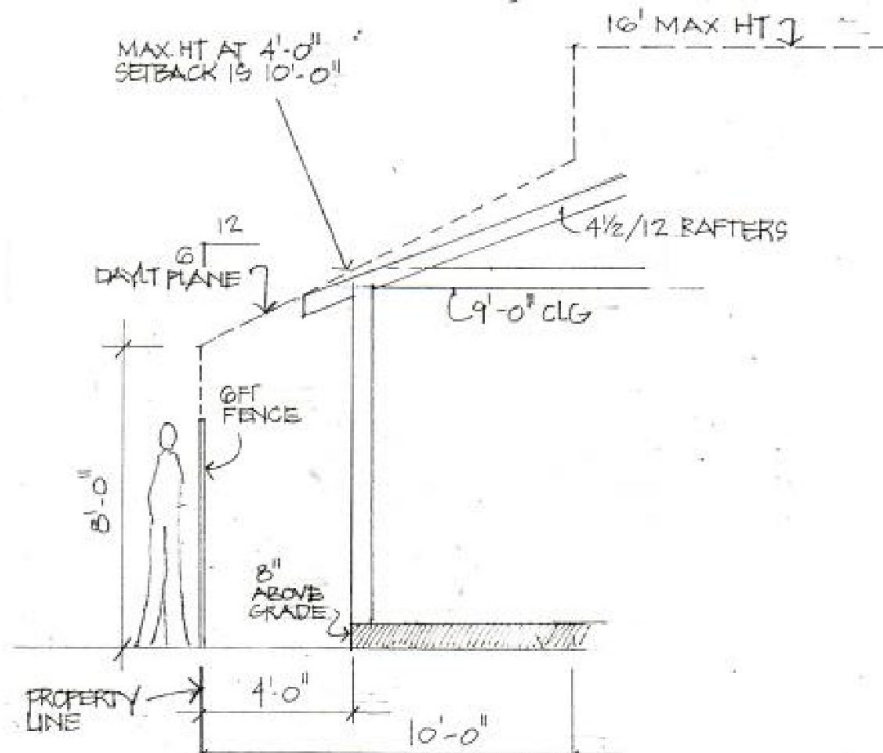

Figure 1-Standard Daylight Plane Diagram

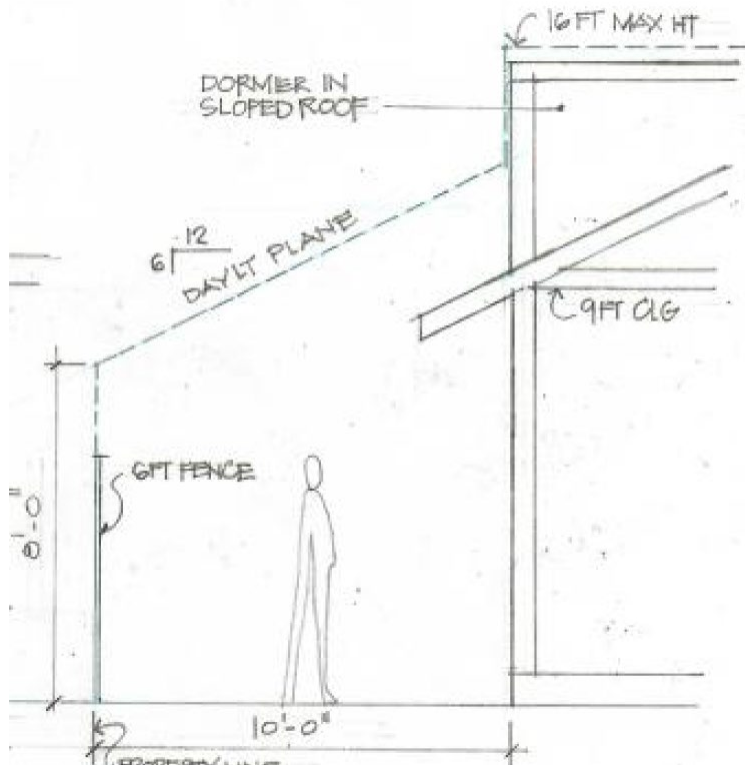

Figure 2-Voluntary Daylight Plane Diagram

(h) A single-family residential ADU must be built in accordance with the building code set forth in Title 12, except that any design, zoning, and building standards inconsistent with state requirements under California Government Code Section 65852.2 shall not apply.

(i) Parking. One (1) additional uncovered parking space of nine feet by eighteen feet (9X18) shall be required for a newly constructed single-family residential ADU, which may be located within the front setback, in tandem and in an existing driveway including within an interior side yard setback area, unless a specific finding is made that such parking is not feasible due to specific site, topographical or fire and life safety. Notwithstanding the above, a parking stall will not be required for a residential ADU that meets any of the following criteria:

(1) The single-family residential ADU is created as a result of the conversion of existing area of the single-family residence or existing permitted residential accessory structure.

(2) An existing garage, carport or parking structure is converted or demolished to accommodate a single-family residential ADU in the same location.

(3) The single-family residential ADU is within one-half (1/2) mile walking distance of a public transit station, such as a bus stop or train station.

(4) The property is within an architecturally and historically significant historic district.

(5) On-street parking permits are required in the area but not offered to the occupant of the residential ADU.

- (6) A vehicle share site is located within one (1) block of the single-family residential ADU.
- (j) Design Standards. Architectural review of attached or detached single-family residential ADUs over 851 square feet or greater will be limited to the following:
- (1) Notwithstanding any other provision of this code, a zoning clearance letter shall be issued for ADUs and shall be reviewed by the director of community development or their designee for compliance with objective design standards as identified within Chapter 14.06(Single Family Zoning Districts) or Chapters 14.16-14.24 (Multi Family Zoning Districts). The permit shall be considered ministerial without discretionary review within the time frames required by Section 65852.2 of the Government Code;
- (2) In those instances where an applicant seeks permission to deviate from the standards, a variance shall be filed in accordance with 14.76.070.
- (3) If the permit application to create an ADU or a JADU is submitted with a permit application to create a new single-family dwelling on the lot, the City may delay acting on the permit application for the ADU or the JADU until the permitting agency acts on the permit application to create the new single-family dwelling, but the application to create the ADU or JADU shall be considered without discretionary review or hearing. If the applicant requests a delay, the 60-day time period shall be suspended for the period of the delay.
- (4) The architectural features, window styles, roof slopes, exterior materials, colors, appearance, and design of the single-family residential ADU must be compatible with the existing single-family dwelling.
- (5) Minimum sill height of 5' (60) inches for windows on the second story within 15' of the property line that face out to the neighbors to try to mitigate privacy concerns shall be required.
- (6) A new single-family residential ADU located within a historic site or neighborhood combining district will be subject to ministerial review for compliance with the design review criteria set forth in section Chapter 12.44 of the Los Altos Municipal Code and must be consistent with the Secretary of Interior's Standards for the Treatment of Historic Properties.
- (7) Outside stairways serving a second story single-family residential ADU shall not be constructed on any building elevation facing a public street.
- (8) No passageway will be required in conjunction with the construction of any single-family residential ADU.
- (k) Streamlined Approval of Accessory Dwelling Units. Notwithstanding the restrictions above, a building permit application for a detached, single-family residential ADU within a residential or mixed-use zone must be a ministerial approved if it is:
- (1) Setback at least four (4) feet from the interior side and rear lot lines. Four feet setbacks is the maximum the City can recommend per state law, but applicants are encouraged to voluntarily comply with the setbacks identified within 14.14.080 of ten (10) feet from the side and rear property lines so as to reduce privacy impacts.

- (2) No larger than eight hundred and fifty (850) square feet in floor area; and
- (3) No taller than sixteen (16) feet in height.

(l) Annual Rental Data. On an annual basis property owner shall be requested to submit voluntarily rental data for use by the City for the Regional Housing Needs Allocation process.

14.14.060 JADU standards.

Notwithstanding any other provisions in this Article or of this chapter to the contrary, a JADU shall be permitted and comply with the following:

- (a) . The owner shall reside in the primary single-family residential dwelling unit or the JADU .
- (b) One (1) JADU may be permitted per residential lot zoned for a single-family residential use, provided that the lot has not more than one (1) existing or proposed single-family residence. A single-family residential lot may have both one(1) JADU and one detached accessory dwelling unit.
- (c) The unit must be constructed within the existing walls of a single-family dwelling except that an expansion of 150 square feet beyond the existing physical dimensions of the primary single family residential dwelling unit may be permitted to accommodate required ingress and egress.
- (d) The square footage of the unit shall be at least the minimum size (150 square feet) required for an efficiency unit, up to a maximum size of five hundred (500) square feet in floor area, and must include one bedroom or studio sleeping area.
- (e) A separate entrance from the unit to the exterior of the residence, and an interior connection to the main living area may be provided. A second interior doorway for sound attenuation may also be permitted.
- (g) At least an efficiency kitchen must be provided in the unit which shall include all the following:
 - (1) A cooking facility with appliances. Appliances can include hot plate, or counter-top cooking. A property owner does not need to have a wall installed oven or stove to qualify for a cooking appliance.
 - (2) A food preparation counter and storage cabinets that are of reasonable size in relation to the size of the JADU.
- (h) The unit may include separate bathroom facilities or may share bathroom facilities contained within the primary single-family residential dwelling unit.
- (i) No separate utility connection, connection fee or capacity charge, or parking space shall be required for a JADU.

- (j) a deed restriction shall be required for JADU and must include the following stipulations:
 - (1) prohibition on the sale of the JADU separate from the sale of the primary single family residential dwelling unit.
 - (2) if a JADU is rented, the unit shall not be rented for a period of less than thirty (30) consecutive days
 - (3) owner occupancy is required for the JADU or the main house, unless the owner is another government agency, land trust or housing organization as allowed by State Law.
- (k) Annual Rental Data. On an annual basis property owner shall be requested to submit voluntarily rental data for use by the City for the Regional Housing Needs Allocation process.

14.14.070 Multi Family ADU Standards in Multi Family Zoning Districts)

Notwithstanding any other provisions of this chapter to the contrary, multi-family ADUs shall be permitted and comply with the following:

- (a) The type of ADUs described in the single-family portion of the ordinance may be built on a multifamily site, subject to the requirements of this section.
- (b) Portions of existing multi-family dwelling structures that are not used as livable space (including, but not limited to, storage rooms, boiler rooms, passageways, attics, basements, or garages), may be converted for use as ADUs provided that total number of units must not exceed twenty-five (25) percent of the existing multi-family dwelling units or one (1) unit, whichever is greater.
- (c) An owner may also construct up to a maximum of two detached ADUs on a lot that has an existing multifamily dwelling, subject to a height limit of sixteen (16) feet and at least four (4) foot rear yard and side setbacks. If there are inconsistencies between this Chapter and other provisions of the Los Altos municipal code, this Chapter shall prevail over those other provisions.
- (d) ADUs in multi-family zone districts shall comply with Government Code Section 65852.2.
- (e) Annual Rental Data. On an annual basis property owner shall be requested to submit voluntarily rental data for use by the City for the City’s Regional Housing Needs Allocation process.

14.14.080 Voluntary Additional Setback

For a detached accessory dwelling unit, the minimum setbacks shall be five feet (5) from the primary residence, and four feet (4) from the side and rear property lines. However, to reduce the privacy impacts to abutting property owners, applicants are encouraged to voluntarily increases the setbacks to be ten (10) feet from the rear and interior property lines. . If an applicant provides the ten (10) foot rear and side property line setbacks, the daylight plane provisions will not be enforced for detached accessory dwelling units.

14.14.090 Voluntary ADU Rental Income Survey

City staff are directed to send out an annual ADU rental income survey to be released no later than September 1st of every calendar year. The property owner can voluntarily share the rental income for the unit with the City for purposes of Los Altos meeting its Regional Housing Needs Allocation (RHNA) Housing Element figures.

SECTION 2. CONSTITUTIONALITY. If any section, subsection, sentence, clause or phrase of this code is for any reason held to be invalid or unconstitutional, such decision shall not affect the validity of the remaining portions of this code.

SECTION 3. CEQA. The City Council finds the adoption of this ordinance to be statutorily exempt from the requirements of the California Environmental Quality Act (CEQA) pursuant to Section 21080.17 of the Public Resources Code because it is an ordinance regarding second units in single-family and multifamily residential zones to implement the provisions of Government Code Section 65852.2.

SECTION 4. PUBLICATION. This ordinance shall be published as provided in Government Code section 36933. Within 15 days of the passage of this ordinance, the City Clerk shall cause the full text of the ordinance, with the names of those City Council members voting for and against the ordinance, to be published in an adjudicated newspaper. In lieu of publishing the full text of the ordinance, the City Clerk, if so directed by the City Attorney and within 15 days, shall cause a summary of the ordinance, prepared by the City Attorney and with the names of the City Council members voting for and against the ordinance, to be published in an adjudicated newspaper, and shall post in the office of the City Clerk a certified copy of the full text of the ordinance, along with the names of those City Council members voting for and against the ordinance. The publication of a summary of the ordinance in lieu of the full text of the ordinance is authorized only where the requirements of Government Code Section 36933(c)(1) are met.

SECTION 5. EFFECTIVE DATE. This ordinance shall be effective upon the commencement of the thirty-first day following the adoption date.

SECTION 6. TRANSMISSION TO HCD. The City Clerk shall send a certified copy of this ordinance to the Department of Housing and Community Development (HCD) within sixty (60) days after adoption, as required by state law.

The foregoing ordinance was duly and properly introduced at a regular meeting of the City Council of the City of Los Altos held on September 8, 2020 and was thereafter, at a regular meeting held on _____, 2020 passed and adopted by the following vote:

- AYES:
- NOES:
- ABSENT:
- ABSTAIN:

Janis C. Pepper, MAYOR

Attest:

Andrea Chelemengos, CITY CLERK



_____ CALENDAR

Agenda Item # ____

AGENDA REPORT SUMMARY

Meeting Date: July 14, 2020

Subject: Repeal and Replace Chapter 14.14 of the Los Altos Municipal Code (Accessory and Junior Dwelling Units) by adopting Zoning Text Amendment 20-0001

Prepared by: Guido F. Persicone, Planning Services Manager, AICP

Reviewed by: Jon Biggs, Community Development Director and
Jolie Houston, City Attorney

Attachment(s):

- A. Draft ADU Ordinance
- B. June 18, 2020 Planning Commission Staff Report
- C. May 21, 2020 Planning Commission Staff Report
- D. May 7, 2020 Planning Commission Staff Report
- E. April 16, 2020 Planning Commission Staff Report
- F. April 16, 2020 Planning Commission Meeting Minutes
- G. May 7, 2020 Planning Commission Meeting Minutes

Initiated by:

City staff due to recent changes to state law.

Previous Council Consideration:

The City Council has not reviewed this particular set of amendments to the accessory dwelling unit (ADU) regulations, but did review a new ADU regulations in 2018

Fiscal Impact:

No direct fiscal impact is anticipated.

Environmental Review:

Adoption of an accessory dwelling unit ordinance is subject to a statutory exemption from environmental review (Public Resource Code Section 15282(h)). In addition, the action being considered does not constitute a “project” within the meaning of the California Environmental Quality Act (“CEQA”) pursuant to CEQA Guidelines Section 15061(b)(3) as the activity is covered by the general rule that CEQA applies only to projects which have the potential for causing a significant effect on the environment. Where it can be seen with certainty that there is no possibility that the activity in question may have a significant effect on the environment, the activity is not subject to CEQA. Projects that are subject to the ADU regulations will be evaluated pursuant to CEQA on an individual basis. However, ADUs are generally exempt from CEQA review under CEQA Guidelines Section 15301 (Existing Facilities) and/or Section 15303 (New Construction or Conversion of Small Structures).



Subject: Proposed Amendments to the Chapter 14.14 (Accessory Dwelling Unit) Ordinance
Second Planning Commission Meeting

Policy Question(s) for Council Consideration:

- Do the proposed code amendments ensure the Los Altos Municipal Code is consistent with recent changes to state law?

Summary:

- The ordinance repeals and replaces Chapter 14.14, Accessory Dwelling Units, to ensure consistency with State law.

Staff Recommendation:

The Planning Commission and staff recommend that the City Council introduce and waive further reading of the proposed ordinance

Purpose

The purpose of the proposed amendments is to ensure compliance with new state laws affecting the development of accessory dwelling unit and junior accessory dwelling units in the residential zone districts of the City.

Background

On April 16, 2020 the Planning Commission reviewed the draft accessory dwelling unit ordinance (ADU). At the conclusion of the meeting, the Commission requested that the ordinance be revised and brought back for consideration at the next Planning Commission meeting.

In addition to the Commission's edits, on the day of the hearing the State office of Housing and Community Development Department (State HCD) reached out to City staff to provide some direction on edits that would be necessary to receive State support for the draft ordinance. This was extremely helpful as State approval within sixty (60) days of adoption is a legal requirement of the most recent legislation.

On May 7, 2020, the Planning Commission reviewed the draft ordinance and directed staff to bring the ordinance back for review at the May 21, 2020 meeting.

On May 21, 2020, approximately forty-five minutes before the public hearing, City staff received a detailed letter from an attorney representing Californian's For Homeownership. Due to the detailed comments, City staff requested, and the Commission agreed, that continuing the item to the June 4, 2020 meeting would be the best scenario so the City could adequately respond to the comment letter.

After publication of the June 4, 2020 staff report City staff met with State HCD. They requested several additional edits to the draft document. As a result of these edits the Planning Commission



Subject: Proposed Amendments to the Chapter 14.14 (Accessory Dwelling Unit) Ordinance
Second Planning Commission Meeting

agreed to continue the item to the June 18, 2020 meeting. It should be noted that a lot of the requested edits from State HCD were driven by the Californian's for Homeownership group an organization established by California Association of Realtors.

On June 18, 2020 the Planning Commission recommended approval of the Zoning Text Amendment, project reference No. Amendment ZTA 20-0001, and made the following modifications to the ordinance:

14.14.021 Categories of ADUs

A chart has been added to the ordinance to help clarify the various types of accessory dwelling units (ADUs). The Planning Commission requested an edit to make it clear that junior accessory dwelling units should be allowed within existing or proposed houses:

Design Standards	Junior ADU	Attached ADU (single-family)	Detached ADU (single-family)
Maximum Size (see 14.14.025 for additional details)	500 sq. ft. created from the existing <u>or</u> <u>proposed</u> square footage of the residential structure.	1,200 sq. ft. but no more than 50% of the floor area of an existing or proposed primary dwelling unit (<u>excluding</u> basement area).	1,200 sq. ft. <u>including</u> basement area).

14.14.050(d)(2) Size of ADUs

The Planning Commission recommended that the maximum square foot for an ADU remain at 1,200 square feet. Additionally, the 50% threshold that currently limits ADUs in the 2018 ordinance, per direction from State HCD can only be applied to attached ADUs. The language has been modified as such:

*(2) A **detached** single-family residential accessory dwelling unit shall not exceed eight hundred fifty (850) square feet in floor area, or one thousand (1,200) square feet for a detached accessory dwelling unit with more than one (1) bedroom. Additional square footage above 850 square feet shall be allowed only if the lot meets the lot coverage and floor area ratio requirements for the applicable zoning district. For detached accessory dwelling units, garage area is excluded but basement areas **are included** in the square footage calculation.*



Subject: Proposed Amendments to the Chapter 14.14 (Accessory Dwelling Unit) Ordinance
Second Planning Commission Meeting

*(3) The total floor area for an **attached** accessory dwelling unit shall not exceed one thousand two hundred (1,200) square feet, **excluding** the basement areas, and shall not be more than fifty (50) percent of the floor area of the existing or proposed principal residence. Notwithstanding this 50% threshold requirement, an attached ADU of 850 square feet or smaller cannot be denied. Additional square footage above 850 square feet shall be allowed only if the lot meets the lot coverage and area ratio requirements for the applicable zoning district.*

14.14.050(d)(4) Internal Conversion

This section was also revised per direction from State HCD to state the property owners have an unlimited right to convert the internal portion of their house into an ADU. A friendly amendment to the Planning Commission Zoning Text Amendment motion was made to request that the City Council include verbiage in the ordinance to state that converting the internal portions of a house should not forfeit a property owner's right to the maximum square footage for the house:

(4) A new detached accessory dwelling unit and an addition to the primary dwelling are limited to 1,200 square feet. There is no size limitation on an accessory dwelling unit that is created by converting space within the existing primary dwelling or accessory structure. If a homeowner converts a portion of the primary dwelling for an attached accessory dwelling unit, nothing herein shall prevent the homeowner from replacing the square footage lost, subject to the applicable design rules for the specific zoning district.

14.14.050(f)(1) Four Feet Setback

The Planning Commission recommended that verbiage be added to the ordinance to state that the four setback for side and rear property lines be considered a maximum but to encourage property owners to comply with the voluntary setbacks identified within the 14.14.080 of the draft ordinance. This language has been added:

(1) A single-family residential accessory dwelling unit either attached or detached from the main house must not encroach upon the required front lot line area or four feet from the side yard property line. Four feet setbacks is the maximum the City can recommend per state law, but applicants are encouraged to voluntarily comply with the setbacks identified within 14.14.080 of ten feet from the side and rear property lines so as to reduce privacy impacts.

14.14.050(g)(2) Daylight Plane Provisions

At the May 7, 2020 meeting the Planning Commission modified the daylight plane provisions to start at eight feet above the property line and slope in at a 6/12 roof pitch. At ten feet from the property line the maximum height of 16 feet would be allowed. To incentivize larger setbacks for privacy, the Planning Commission added a proviso that states that if a property owner voluntarily



Subject: Proposed Amendments to the Chapter 14.14 (Accessory Dwelling Unit) Ordinance
Second Planning Commission Meeting

Fees

In light of the regional housing crisis, reducing fees for all accessory dwelling units (ADUs) is a concrete step Los Altos could take to demonstrate to the community and the California Department of Housing and Community Development (State HCD) that Los Altos wants to encourage production of these units. This is a positive action step that is in line with new Housing Element Law (AB 671) which encourages cities to incentives the construction of ADUs. The Planning Commission recommended the City reduce fees for a period of one (1) year to incentives these housing units.

14.14.060(k)-Annual Rental Data -Regional Housing Needs Allocation (RHNA) and ADUs

Hillsborough

On May 5, 2020 Los Altos city staff spoke with Liz Ruess, Hillsborough Planning Manager. Hillsborough gets credit for their ADUs at the low and very low income RHNA levels. Every year they send out a survey and property owner self-report the rent for the unit. Liz indicated they get about a 50% response rate for the survey that is sent out.

Half Moon Bay

City staff spoke with Scott Phillips from Half Moon Bay (HMB). HMB, similar to Hillsborough, collects rent data from property owner and then receives credit for their units as being moderate income ADUs.

The approach that Hillsborough and Half Moon Bay have taken to gather information to support meeting their RHNA goal is supported by State HCD per a memo prepared by the 21 Elements Group: <http://21elements.com/documents-mainmenu-3/housing-elements/rhna-5-2014-2022/sites-inventory/655-affordability-of-second-units>

Los Altos should begin a process of collecting ADU data to support meeting our long term RHNA goals. The draft ordinance had a requirement for payment of a fee for annual recertification. The Planning Commission felt that payment of a fee and inspection of the housing unit was a bit “heavy handed” as such this portion of the ordinance has been modified to say that submittal of rental information shall be done on a voluntary basis. The verbiage related to recertification has been removed.

(k) Annual Rental Data. On an annual basis property owners shall ~~voluntarily~~ provide the City staff access to the accessory dwelling unit to ensure compliance with the approved plans and ~~voluntarily~~ submit rental data for use by the City for the Regional Housing Needs Allocation process.



Subject: Proposed Amendments to the Chapter 14.14 (Accessory Dwelling Unit) Ordinance
Second Planning Commission Meeting

State HCD Requested Edits

Below are a series of edits requested by State HCD in order to receive its approval after adoption by the City Council:

Four Feet Setback

Verbiage was added to make it clear that either attached or detached ADU must be no more than four (4) feet from the side or rear property lines.

A single-family residential accessory dwelling unit either attached or detached from the main house must not encroach upon the required front lot line area or four feet from the side yard property line.

Parking Nonconformance

City staff and the Commission agreed to add verbiage about making property owners submit a letter stating if they convert the garage this could create a nonconforming situation for the main house moving forward. State HCD requested this be removed because they felt this overstepped the authority of the City in terms of enforcement of the ADU ordinance.

An existing garage, carport or parking structure is converted or demolished to accommodate a single-family residential accessory dwelling unit in the same location. ~~If the required parking for the main single family residence is removed the property owner must submit a notarized letter to the City acknowledging removal of said parking could create a nonconformity for future expansions of the single family dwelling.~~

Multi Family Housing and ADUs-

A proviso was added to the multi-family housing section of the ordinance to make it clear that the requirements for ADUs in single-family and multi-family homes are compatible with each other:

(a) The type of ADUs described in the single-family portion of the ordinance may also be built on a multifamily site if so desired.

Multi-Family Housing and Other Regulatory Conflicts-

To make it completely clear we wanted to say that if there is a conflict between the ADU ordinance and other sections of the municipal code, this ordinance shall prevail.

(c) An owner may also construct up to a maximum of two detached accessory dwelling units on a lot that has an existing multifamily dwelling, subject to a height limit of sixteen (16) feet and four (4) foot rear yard and side setbacks. If there are inconsistencies between this Chapter and other provisions of the Los Altos municipal code, this Chapter shall prevail over those other provisions.



Subject: Proposed Amendments to the Chapter 14.14 (Accessory Dwelling Unit) Ordinance
Second Planning Commission Meeting

Multi-Family Housing and Amenities-

State HCD requested that additional language be removed to make it clear that project amenities within the interior of a multifamily housing project could be converted to an ADU.

Portions of existing multi-family dwelling structures that are not used as livable space (including, but not limited to, storage rooms, boiler rooms, passageways, attics, basements, or garages), ~~but excluding any residential amenities required to be provided for the facility by the zoning ordinance, or as a condition of project approval,~~ may be converted for use as accessory dwelling units provided that total number of units must not exceed twenty-five (25) percent of the existing multi-family dwelling units or one (1) unit, whichever is greater.

Conclusion

- 1) The Planning Commission and staff recommend that the City Council introduce and waive further reading of the proposed ordinance
- 2) Adopt Zoning Text Amendment 20-0001 and further find the project is exempt from CEQA per Section 21080.17 of the Public Resources Code.
- 3) Amend the Master Fee Schedule to reduce the ADU permit fees for accessory dwelling units for a period of twelve (12) months after final adoption by the City Council of the ordinance.
- 4) Direct staff to prepare an annual ADU rental income survey to be released no later than September 1st of every calendar year. To collect said data and to report this information to State HCD for purposes of meeting the City's RHNA Housing Element figures.

Los Altos General Plan Conformance

General Plan Land Use Goal 2: Review and amend (as needed) the Zoning Ordinance to provide consistency with new state legislation and court decisions. Consider Zoning Ordinance amendments that implement the use and development of goals, policies and plan objectives for the identified planning areas (Downtown, El Camino Real Corridor, and Foothill Plaza).

Housing Element Policy 4.2: The City will encourage the development of affordable second dwelling units that conform to zoning regulations.

Program 4.2.1 – Facilitate new construction of second dwelling units.

Program 4.2.2-Study the feasibility of reducing minimum lot sizes for second living units.



Subject: Proposed Amendments to the Chapter 14.14 (Accessory Dwelling Unit) Ordinance
Second Planning Commission Meeting

Options

1) Approve Zoning Text Amendment 20-0001

Advantages: Ensure compliance with new state laws.

Disadvantages: Results in less control over accessory dwelling units in Los Altos.

2) Direct staff to make further edits to the ordinance and bring the document back from a first reading of the City Council in August

Advantages: There is no advantage to denying this ordinance as noncompliance with State law is not a viable position for a municipal agency to be in.

Recommendation

The staff recommends Option 1.



ITEMS FOR DISCUSSION/ACTION Agenda Item # 2
--

AGENDA REPORT SUMMARY

Meeting Date: June 18, 2020

Subject: Repeal and Replace Chapter 14.14 of the Los Altos Municipal Code (Accessory and Junior Dwelling Units) by adopting Zoning Text Amendment 20-0001

Prepared by: Guido F. Persicone, Planning Services Manager, AICP

Reviewed by: Jon Biggs, Community Development Director and
Jolie Houston, City Attorney

Attachment(s):

- A. Draft ADU Ordinance
- B. Daylight Plane Diagrams
- C. Californians Letter to the Planning Commission, date May 21, 2020
- D. State HCD Edits on the Draft Ordinance

Initiated by:

City staff

f

Previous Council Consideration:

2018

Fiscal Impact:

No direct fiscal impact is anticipated

Environmental Review:

Adoption of an accessory dwelling unit ordinance is subject to a statutory exemption from environmental review (Public Resource Code Section 15282(h)). In addition, the action being considered does not constitute a “project” within the meaning of the California Environmental Quality Act (“CEQA”) pursuant to CEQA Guidelines Section 15061(b)(3) as the activity is covered by the general rule that CEQA applies only to projects which have the potential for causing a significant effect on the environment. Where it can be seen with certainty that there is no possibility that the activity in question may have a significant effect on the environment, the activity is not subject to CEQA. Projects that are subject to the ADU regulations will be evaluated pursuant to CEQA on an individual basis. However, ADUs are generally exempt from CEQA review under CEQA Guidelines Section 15301 (Existing Facilities) and/or Section 15303 (New Construction or Conversion of Small Structures).

Policy Question(s) for Council Consideration:

- Do the proposed code amendments ensure the Los Altos Municipal Code is consistent with recent changes to state law?



Subject: Proposed Amendments to the Chapter 14.14 (Accessory Dwelling Unit) Ordinance
Second Planning Commission Meeting

Summary:

- The ordinance repeals and replaces Chapter 14.14, Accessory Dwelling Units, to ensure consistency with State law.

Staff Recommendation:

Staff suggests that the Planning Commission recommend adoption of the proposed ordinance to the City Council.

Purpose

The purpose of the proposed amendments is to ensure compliance with new state laws affecting the development of accessory dwelling unit and junior accessory dwelling units in the residential zone districts of the City.

Background

On April 16, 2020 the Planning Commission reviewed the draft accessory dwelling unit ordinance (ADU). At the conclusion of the meeting, the Commission requested that the ordinance be revised and be reviewed by the legislative body at the May 7, 2020 meeting.

In addition to the Commission's edits, on the day of the hearing the State Housing and Community Development Department (State HCD) reached out to City staff to provide some direction on edits that would be necessary to receive State support for the draft ordinance. This was extremely helpful as State approval within sixty (60) days of adoption is a legal requirement from the most recent legislation.

On May 7, 2020, the Planning Commission reviewed the draft ordinance and directed staff to bring the ordinance back for review at the May 21, 2020 meeting.

On May 21, 2020, approximately forty-five minutes before the public hearing, City staff received a detailed letter from the Californian's For Homeownership. Due to the detailed comments, City staff requested, and the Commission agreed, that continuing the item to the June 4, 2020 meeting would be the best scenario so the City could adequately respond to the comment letter.

After publication of the June 4, 2020 staff report City staff met with State HCD. They requested several additional edits to the draft document. As a result of these edits the Planning Commission agreed to continue the item to the June 18, 2020 meeting. It should be noted that a lot of the requested edits from State HCD were driven by the California for Homeownership group an organization established by California Association of Realtors.



Subject: Proposed Amendments to the Chapter 14.14 (Accessory Dwelling Unit) Ordinance
Second Planning Commission Meeting

May 7, 2020 Major Modifications to the Ordinance

Categories of ADU-A chart has been added to the ordinance to summarize the key standards that apply to the various types of ADU's in the new regulations.

Section 14.14.021 (Square Footage Chart)-The Planning Commission requested that City staff revise the square footage chart identified within Section 14.14.025 of the draft ordinance. Said modifications have been made.

Daylight Plane Provisions-At the May 7, 2020 meeting the Planning Commission modified the daylight plane provisions to start at eight feet above the property line and slope in at a 6/12 roof pitch. At ten feet from the property line the maximum height of 16 feet would be allowed.

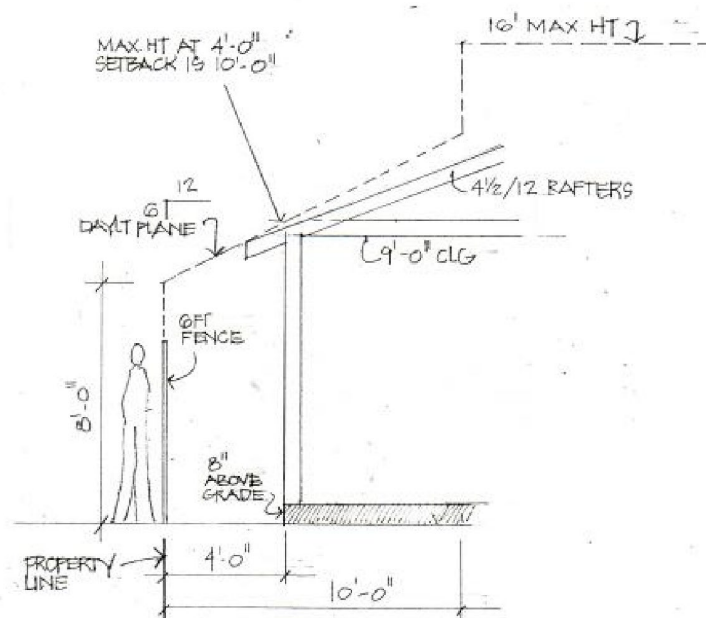

State HCD Requested Edits

Four Feet-verbiage was added to make it clear that either attached or detached ADU has to be no more than four (4) feet from the side or rear property lines.

A single-family residential accessory dwelling unit either attached or detached from the main house must not encroach upon the required front lot line area or four feet from the side yard property line.

May 21, 2020



Subject: Proposed Amendments to the Chapter 14.14 (Accessory Dwelling Unit) Ordinance
Second Planning Commission Meeting

Parking Nonconformance-City staff and the Commission agreed to add verbiage about making property owners submit a letter stating if they convert the garage this could create a nonconforming situation for the main house moving forward. State HCD requested this be removed because they felt this overstepped the authority of the City in terms of enforcement of the ADU ordinance.

An existing garage, carport or parking structure is converted or demolished to accommodate a single-family residential accessory dwelling unit in the same location. ~~If the required parking for the main single family residence is removed the property owner must submit a notarized letter to the City acknowledging removal of said parking could create a nonconformity for future expansions of the single family dwelling.~~

Multi Family Housing and ADUs-a proviso was added to the multi family housing section of the ordinance to make it clear that the requirements for ADUs in single family and multi family house are compatible with each other:

(a) The type of ADUs described in the single-family portion of the ordinance may also be built on a multifamily site if so desired.

Multi Family Housing and Other Regulatory Conflicts-To make it completely clear we wanted to say that if there is a conflict between the ADU ordinance and other portions of the municipal code, this ordinance shall prevail.

(c) An owner may also construct up to a maximum of two detached accessory dwelling units on a lot that has an existing multifamily dwelling, subject to a height limit of sixteen (16) feet and four (4) foot rear yard and side setbacks. If there are inconsistencies between this Chapter and other provisions of the Los Altos municipal code, this Chapter shall prevail over those other provisions.

Multi-Family Housing and Amenities-State HCD requested that additional language be removed to make it clear that project amenities within the interior of a multi family housing project could be converted.

Portions of existing multi-family dwelling structures that are not used as livable space (including, but not limited to, storage rooms, boiler rooms, passageways, attics, basements, or garages), ~~but excluding any residential amenities required to be provided for the facility by the zoning ordinance, or as a condition of project approval,~~ may be converted for use as accessory dwelling units provided that total number of units must not exceed twenty-five (25) percent of the existing multi-family dwelling units or one (1) unit, whichever is greater.



Subject: Proposed Amendments to the Chapter 14.14 (Accessory Dwelling Unit) Ordinance
Second Planning Commission Meeting

50% Rule-City staff kept this provision in the proposed ordinance because it was thoroughly discussed by the City Council during the last ADU ordinance update. State HCD directed city staff that the 50% rule can only apply to attached ADUs. Additionally, since the City is losing local land use control on the attached ADUs, it is recommended that the overall size of the units be reduced to no more than 1,000 square feet. The language has been modified as such:

*(2) A **detached** single-family residential accessory dwelling unit shall not exceed eight hundred fifty (850) square feet in floor area, or one thousand (1,000) square feet for a detached accessory dwelling unit with more than one (1) bedroom. Additional square footage above 850 square feet shall be allowed only if the lot meets the lot coverage and floor area ratio requirements for the applicable zoning district. For detached accessory dwelling units, garage area is excluded but basement areas **are included** in the square footage calculation.*

*(3) The total floor area for an **attached** accessory dwelling unit shall not exceed one thousand two hundred (1,000) square feet, **excluding** the basement areas, and shall not be more than fifty (50) percent of the floor area of the existing or proposed principal residence. Notwithstanding this 50% threshold requirement, an attached ADU of 850 square feet or smaller cannot be denied. Additional square footage above 850 square feet shall be allowed only if the lot meets the lot coverage and area ratio requirements for the applicable zoning district.*

800 Square Feet vs. 850 Square Feet-As has been discussed, the six State laws providing conflict information for when 800 or 850 square feet should be allowed for an ADU. As the distinction between an 800 and 850 square foot unit is negligible and has caused confusion among members of the public, City staff along with the City Attorney are recommending that up to 850 square feet be allowed for an ADU on a site that is at or in excess of lot coverage and floor area standards, with the words up to meaning an applicant can create a unit smaller but the City must grant up to 850 square feet for the ADU if desired by the property owner.

Fees-In light of the regional housing crisis, reducing fees for all accessory dwelling units (ADUs) is a concrete step Los Altos could take to demonstrate to the community and the California Department of Housing and Community Development (State HCD) that Los Altos wants to encourage production of these units. No final direction was provided to staff regarding potential reduction of said fees. At the conclusion of the May 21, 2020 meeting, City staff are requesting that the motion for the zoning text amendment to the City Council include a recommendation either in the affirmative, namely reduction of fees, or in the negative (to keep fees as identified in the Master Fee Schedule).



Subject: Proposed Amendments to the Chapter 14.14 (Accessory Dwelling Unit) Ordinance
Second Planning Commission Meeting

Hybrid Model - During the April 23rd and May 7th Commission meetings members of the public provided a possible scenario in which a property owner could take square footage already existing in a house (500 square feet) have it refurbished for an ADU and then add 350 square feet for an 850 square foot ADU. This suggestion was to then take the 500 square feet used for the ADU and add this area to another portion of the house with the end result the same square footage allowable for the lot.

Table 1 (Hybrid Scenario)	
3800 square foot max for a house	3,300 main house
850 square foot max for an ADU	+500 square foot ADU remodel with a 350 sq. ft. addition) +500 for another addition to the house
Total=4,560 total square feet	Total 4,650 total square feet.

The Planning Commission inquired if this would require a revision to the ordinance to create a new subclass of ADUs. The City staff answer is no as this would still be classified as an attached ADU. This is a policy recommendation that City staff is not going to take a position on. On one hand, it makes sense that the amount of square footage would be the same and could create a better integrated attached ADU. On the other hand, it could be a potential way to circumvent the floor area ratio caps within the Municipal Code. Additionally, constant monitoring of this could be problematic. Under this scenario, a property owner could take out the kitchen, and separate bathroom facilities after approval by the City. Without monitoring, property owners could essentially be granted houses that exceed the allowable floor area ratio for a property while not meeting the real intent of the ADU legislation, which is to foster the development of units to help ease the affordable housing crisis.

However, having said all of that, in conversations with the 21 Elements Group and the City of Hillsborough, the City of Los Altos can receive Housing Element RHNA credit if it monitors the rent of ADUs moving forward. Hillsborough through submittal of a voluntary survey receives RHNA credits for its low and very low income units. Deed restrictions are not required. If the Planning Commission and City Council want to move forward with this hybrid approach, a policy compromise could be provided to allow this integrated approach but to require property owners to pay an annual inspection fee and to report the rental income data for the all ADUs within Los Altos.

Regional Housing Needs Allocation (RHNA) and ADUs

Hillsborough-On May 5, 2020 Los Altos city staff spoke with Liz Ruess, Hillsborough Planning Manager. Hillsborough gets credit for their ADUs at the low and very low income RHNA levels.



Subject: Proposed Amendments to the Chapter 14.14 (Accessory Dwelling Unit) Ordinance
Second Planning Commission Meeting

Every year they send out a survey and property owner self-report the rent for the unit. Liz indicated they get about a 50% response rate for the survey that is sent out.

Half Moon Bay-City staff spoke with Scott Phillips from Half Moon Bay (HMB). HMB, similar to Hillsborough, collects rent data from property owner and then receives credit for their units as being moderate income ADUs.

The approach that Hillsborough and Half Moon Bay have taken to gather information to support meeting their RHNA goal is supported by State HCD per a memo prepared by the 21 Elements Group: <http://21elements.com/documents-mainmenu-3/housing-elements/rhna-5-2014-2022/sites-inventory/655-affordability-of-second-units>

Los Altos should begin a process of collecting ADU data to support meeting our long term RHNA goals. City staff are requesting that as part of the motion to approve the Zoning Text Amendment that the Planning Commission also encourage the City Council to adopt a resolution creating an annual ADU Recertification Program supported by payment of an annual inspection fee from property owners.

Conclusion

The Planning Commission has asked City staff a lot of great questions and really forced members of the community to think about the overall intentions of implementing these state laws. As of January 1, 2020, state laws regarding ADUs prevail, without a daylight plane and other characteristics unique to Los Altos. City staff are recommending a vote on the ordinance, so the City Council has an opportunity to deliberate to maintain some semblance of local land use control for ADUs moving forward.

Los Altos General Plan Conformance

General Plan Land Use Goal 2: Review and amend (as needed) the Zoning Ordinance to provide consistency with new state legislation and court decisions. Consider Zoning Ordinance amendments that implement the use and development of goals, policies and plan objectives for the identified planning areas (Downtown, El Camino Real Corridor, and Foothill Plaza).

Housing Element Policy 4.2: The City will encourage the development of affordable second dwelling units that conform to zoning regulations.

Program 4.2.1 – Facilitate new construction of second dwelling units.

Program 4.2.2-Study the feasibility of reducing minimum lot sizes for second living units.

Options



Subject: Proposed Amendments to the Chapter 14.14 (Accessory Dwelling Unit) Ordinance
Second Planning Commission Meeting

1) Recommend approval of Zoning Text Amendment 20-0001 to the City Council.

Advantages: Ensure compliance with new state laws.

Disadvantages: Results in less control over accessory dwelling units in Los Altos.

2) Recommend denial of the draft ordinance to the City Council

Advantages: There is no advantage to denying this ordinance as noncompliance with State law is not a viable position for a municipal agency to be in.

Recommendation

The staff recommends Option 1.

ORDINANCE NO. 2020-___

**AN ORDINANCE OF THE CITY COUNCIL OF THE CITY OF LOS ALTOS
REPEALING AND REPLACING THE ACCESSORY DWELLING UNIT
ORDINANCE AND MAKING FINDINGS OF CEQA EXEMPTION**

WHEREAS, the State Legislature has found that accessory dwelling units are a necessary and valuable form of housing in California; and

WHEREAS, accessory dwelling units help diversify the City's housing stock and help provide rental units that are affordable; and

WHEREAS, accessory dwelling units offer lower cost housing to meet the needs of existing and future residents within existing neighborhoods, while respecting neighborhood character; and

WHEREAS, accessory dwelling units provide housing for family members, students, the elderly, in-home health care providers, the disabled, and others within existing neighborhoods; and

WHEREAS, it is the intent of this ordinance to allow and promote the development of accessory dwelling units; and

WHEREAS, this Ordinance implements Program 4.2.1 and Program 4.2.2 of the City's 2015-2023 Housing Element by facilitating the development of new accessory dwelling units; and

WHEREAS, this Ordinance is exempt from environmental review pursuant to Section 15061 and Section 15301 of the California Environmental Quality Act Guidelines, as amended.

NOW THEREFORE, the City Council of the City of Los Altos does hereby ordain as follows:

SECTION 1. AMENDMENT OF CODE: Chapter 14.14 of Title 14 of the Los Altos Municipal Code is hereby repealed in its entirety and replaced with the new standards and shall read as follows:

Section 14.14.010 Purpose and Intent.

The intent of this chapter is to provide for accessory dwelling units and junior accessory dwelling units, collectively known as an accessory dwelling, on lots zoned to allow single-family or multifamily dwelling residential use that include a proposed or existing dwelling. Accessory dwelling units contribute needed housing to the City of Los Altos housing stock and enhance housing opportunities. An accessory dwelling unit is considered a residential use that is consistent with the existing general plan and zoning designations for the lot. The accessory dwelling unit is not included in calculation of residential density for the purposes of determining general plan conformance.

14.14.020 Definitions.

As used in this section, the following terms mean:

“Accessory dwelling unit” (or “ADU”) means an attached or a detached residential dwelling unit that provides complete independent living facilities and is located on a lot with a proposed or existing primary residence. It shall include permanent provisions for living, sleeping, eating, cooking, and sanitation on the same parcel as the single-family or multi-family dwelling is or will be situated. An accessory dwelling unit also includes the following:

(A) An efficiency unit, as defined in Section 17958.1 of the Health and Safety Code.

(B) A manufactured home, as defined in Section 18007 of the Health and Safety Code.

“Attached accessory dwelling unit” means a residential dwelling unit that is created as a result of internal conversion, addition, or combination thereof made to the primary residential dwelling unit.

“Existing,” when referring to an existing principal dwelling, accessory structure, or other building or structure, refers to a building or structure erected prior to the date of adoption of the appropriate building code, or one for which a legal building permit has been issued, as defined in Section 202 of the 2019 California Building Code. An unpermitted building or structure shall not be considered “existing” for purposes of this chapter.

“Multi-family housing” means a dwelling unit or group of dwelling units on one site that contains separate living units for two or more families that may have joined services or facilities or both.

“Junior accessory dwelling unit” (or “junior ADU” or “JADU”) means a unit that is no more than 500 square feet in size, includes an efficiency kitchen consistent with building code standards, is contained entirely within the walls of a single-family residence and may include separate sanitation facilities or may share sanitation facilities with the existing structure or unit.

“Living area” means the interior habitable area of a dwelling unit, including basements and attics, if defined as habitable by the California Residential Code (CRC) but does not include a garage or any accessory structure.

“Nonconforming zoning condition” means a physical improvement on a property that does not conform with current zoning standards.

“Passageway”. The term passageway has the meaning defined by Government Code Section 65852.2, which states: A pathway that is unobstructed clear to the sky and extends from a street to one entrance of the accessory dwelling unit.

“Public transit” means a location, including, but not limited to, a bus stop or train station, where the public may access buses, trains, subways, and other forms of transportation that charge set fares, run on fixed routes, and are available to the public.

“Tandem parking” means that two or more automobiles are parked in any location on a lot and lined up behind one another.

14.14.021 Categories of ADUs

Section 14.14.021 is a summary of the various accessory dwelling unit requirements. If this summary of information conflicts with other sections of this Chapter, those sections shall be binding. See Section 14.14.070 for additional requirements that apply to multi-family ADUs.

Design Standards	Junior ADU	Attached ADU (single-family)	Detached ADU (single-family)
Maximum Size (see 14.14.025 for additional details)	500 sq. ft. created from the existing square footage of the residential structure.	1,000 sq. ft. but no more than 50% of the floor area of an existing or proposed primary dwelling unit (<u>excluding</u> basement area).	1,000 sq. ft. <u>including</u> basement area).
Maximum Height	NA	The greater of 16 feet or the height of zoning underlying zoning district	16 feet
Side Setback	NA	4 feet (see exception identified within 14.14.050(f)(5))	4 feet
Rear Setback	NA	4 feet (see exception identified within 14.14.050(f)(5))	4 feet
Kitchen	Cooking appliances can include hot plate, or counter-top cooking. A wall installed oven is not required.	Must include at least a sink, a refrigerator of no less than 10 cubic feet, and either a cooktop and an oven, or a range. A food preparation counter and storage cabinets that are of reasonable size in relation to the size of the ADU are also required.	
Parking Requirement	None	1 uncovered parking space required. See Section 14.14.050(i)(1-6) for the exceptions to this requirement	
Owner Occupancy	Required	Not required	

Short Term Rentals	Prohibited	Prohibited
Impact Fees	None	750 sq. ft. or less-no impact fees 751 sq. ft or more-impact fees are proportionate to principal dwelling.
Utility Fees and Connections	None required.	The accessory dwelling may be served by the primary residence or may have separate utility meters.

14.14.025 Square Footage Chart

For clarity the following chart provides the square footage thresholds for the various forms of accessory dwelling units

Unit Type	Square Footage Limitations
Efficiency Unit	The minimum size of an efficiency unit as defined by the Health and Safety Code shall be 150 square feet.
Junior Accessory Dwelling Unit	The maximum size of a Junior Accessory Dwelling Unit (JADU) shall be 500 square feet created by the conversion of existing square footage of the dwelling unit. However, up to 150 square feet can be added to the existing structure for purposes of ingress and egress to the JADU. The additional square footage shall count towards the 500 square foot maximum.
<u>Attached accessory dwelling unit</u>	The total floor area for an attached accessory dwelling unit shall not exceed one thousand two hundred (1,000) square feet, excluding the basement areas, and shall not be more than fifty (50) percent of the floor area of the existing or proposed principal residence. Notwithstanding this 50% threshold requirement, an ADU of 850 square feet or smaller cannot be denied. More specific requirements are set forth in Section 14.14.050(d).
<u>Detached accessory dwelling unit</u>	The total floor area for a detached accessory dwelling unit shall not exceed eight hundred fifty (850) square feet, including basement areas of the detached unit, for any studio or one-bedroom detached accessory dwelling unit or one thousand (1,000) square feet for any detached accessory dwelling unit with two or more bedrooms.
Accessory dwelling unit subject to	An ADU between 851-1,000 square feet are subject to a zoning clearance review for objective design standards as identified in Chapter 14.06-Chapter 14.16-24.

objective standards	design
---------------------	--------

Section 14.14.030 Location Permitted

A. Accessory dwelling units may be permitted in the following zones: on lots zoned for multifamily or single-family dwellings.

B. Nothing in this chapter shall be construed to authorize construction of new single-family residences in multiple-family districts where such single-family residential use is not otherwise allowed.

14.14.040 General Requirements.

Notwithstanding any local ordinance regulating the issuance of variances or special use permits, or regulations adopted herein to the contrary, an application for a building permit to construct an accessory dwelling unit, or junior accessory dwelling unit, or efficiency unit (“accessory dwelling”) shall be approved or denied ministerial without discretionary review or hearing within sixty (60) days from the date the city receives a completed application if there is an existing single-family or multifamily structure on the lot. The following requirements apply to all accessory dwellings:

(a) An accessory dwelling shall not be rented for periods less than thirty (30) days. Short term rentals are prohibited.

(b) Except as allowed by State law, an accessory dwelling shall not be sold or have its title transferred separately from the primary residential structure.

(c) Deed Restriction. Prior to the issuance of the building permit for the accessory dwelling unit, the owner must record a deed restriction stating that the accessory dwelling unit may not be rented for periods less than thirty (30) days, and that it may not be transferred or sold separate from the primary residential structure.

(d) The installation of fire sprinklers shall not be required for an accessory dwelling if sprinklers are not required for the primary residence.

(e) Accessory dwellings are subject to the design standards and other zoning requirements of the zoning district in which the existing single-family dwelling is located and must be built in accordance with the building code set forth in Title 12 of the Los Altos Municipal Code, except for those design, zoning, and building standards inconsistent with state requirements under California Government Code Section 65852.2.

(f) An accessory dwelling is not subject to residential accessory structure regulations.

(g) An accessory dwelling will not be subject to any charges and fees other than planning and building permit fees generally applicable to residential construction in the zone in which the property is located, except as otherwise provided herein.

(h) Any connection fees and capacity charges that may be required must be assessed in compliance with the provisions of State Government Code Section 65852.2 and 65852.22, and as the sections may be amended over time by the State.

(i) The accessory dwelling must contain water, sewer and gas and/or electric utility connections that are in working condition upon its occupancy. The accessory dwelling may be served by the primary residence or may have separate utility meters. The accessory dwelling will not be considered a new residential use for the purpose of calculating connection fees or capacity charges for these utilities.

(j) An accessory dwelling unit must have an independent electrical sub-panel, water heating and space heating equipment within the unit or be readily accessible to the occupant on the exterior of the unit.

(k) Ministerial approval of a permit for creation of an accessory dwelling shall not be conditioned on the correction of pre-existing nonconforming zoning conditions.

(l) A certificate of occupancy for any accessory dwelling shall not be issued before the local agency issues a certificate of occupancy for the primary dwelling.

(m) If the applicant requests a delay in processing, the 60-day time period shall be suspended for the period of the delay.

(n) A kitchen shall be provided for an accessory dwelling unit. A full kitchen requires habitable space used for preparation of food that contains at least a sink, a refrigerator of no less than 10 cubic feet, and either a cooktop and an oven, or a range. A food preparation counter and storage cabinets that are of reasonable size in relation to the size of the ADU are also required.

(o) Minimum sill height of 5' (60) inches for windows on the second story within 15' of the property line that face out to the neighbors to mitigate privacy concerns shall be required.

14.14.050 Single-Family Residential Accessory Dwelling Unit Standards

Notwithstanding any other provisions of this chapter to the contrary, a single-family residential accessory dwelling unit shall be a permitted as a single-family residential use that shall comply with the following:

(a) Zoning. A single-family residential accessory dwelling unit shall be located on a lot with an existing or proposed primary dwelling in a residential or mixed-use zone district.

(b) Number. Only one (1) detached or one (1) attached single-family residential accessory dwelling unit may be permitted on a parcel that contains not more than one existing or proposed single-family residence. Additionally, one (1) Junior Accessory Dwelling Unit (JADU) maybe allowed within the confines of the existing house, as allowed by Section 14.14.060(b).

(c) Relationship to Primary Dwelling. A single-family residential accessory dwelling unit may be within, attached to, or detached from, the proposed or existing primary dwelling, provided that a single-family residential accessory dwelling unit contained within or attached to an

existing primary dwelling unit shall have independent exterior access from the existing residence) A detached single-family residential accessory dwelling unit must be located at least five (5) feet from the proposed primary dwelling.

(d) Size.

(1) A studio or one (1) bedroom, attached or detached single-family residential accessory dwelling unit shall be permitted, and limited to eight hundred fifty (850) square feet in floor area, garage areas excluded.

(2) A **detached** single-family residential accessory dwelling unit shall not exceed eight hundred fifty (850) square feet in floor area, or one thousand (1,000) square feet for a detached accessory dwelling unit with more than one (1) bedroom. Additional square footage above 850 square feet shall be allowed only if the lot meets the lot coverage and floor area ratio requirements for the applicable zoning district. For detached accessory dwelling units, garage area is excluded but basement areas **are included** in the square footage calculation.

(3) The total floor area for an **attached** accessory dwelling unit shall not exceed one thousand two hundred (1,000) square feet, **excluding** the basement areas, and shall not be more than fifty (50) percent of the floor area of the existing or proposed principal residence. Notwithstanding this 50% threshold requirement, an attached ADU of 850 square feet or smaller cannot be denied. Additional square footage above 850 square feet shall be allowed only if the lot meets the lot coverage and area ratio requirements for the applicable zoning district.

(4) A new detached accessory dwelling unit and an addition to the primary dwelling are limited to 1,000 square feet. There is no size limitation on an accessory dwelling unit that is created by converting space within the existing primary dwelling or accessory structure.

(e) Height.

(1) The maximum height for a detached single-family residential accessory dwelling unit shall be one-story and sixteen (16) feet.

(2) Attached single-family residential accessory dwelling units shall have a maximum height of equal to the greater of (i) sixteen (16) feet, or (ii) the height limit established for the primary residential structure pursuant to applicable zoning.

(f) Setbacks. A single-family residential accessory dwelling unit is subject to the design criteria and zoning requirements of the district in which the existing single-family dwelling is located and as follows:

(1) A single-family residential accessory dwelling unit either attached or detached from the main house must not encroach upon the required front lot line area or four feet from the side yard property line.

(2) A setback of four (4) feet from the interior side and rear lot lines shall be required for a newly constructed, detached or attached single-family residential accessory dwelling unit that is not constructed in the same location and to the same dimensions as an existing structure.

Proposed structures that are four (4) feet or less from the property line shall be required to provide a record survey to the City for proof of setbacks and existing property lines.

(3) The separation from the principal dwelling and any other accessory structure on the lot shall be at least five (5) feet unless implementation of this requirement would prohibit the construction of an 850 square foot detached accessory dwelling unit, in which case this requirement shall be waived provided the ADU complies with California Building Code (CBC) requirements for separation.

(5) No additional zoning setback is required for conversion of an existing permitted accessory structure, living area, or garage space, or conversion of a structure that is constructed in the same location and to the same dimensions as the existing structure.

(g) Detached Accessory Dwelling Unit Daylight Plane

(1) No portion of an attached or detached accessory dwelling unit shall extend above or beyond a daylight plane as follows:

(2) The daylight plane starts at a height of eight feet at the property line and proceeds inward at a 6:12 slope. At ten feet from the property line the structure can increase in height to sixteen (16) feet. All appurtenances, including chimneys, vents and antennas, shall be within the daylight plane. The daylight plane is not applied to a side or rear property line when it abuts a public alley or public street. However, the accessory dwelling unit (ADU) daylight plane shall not be enforced if it prohibits the development of an 850 square foot ADU which is required by state law.

(3) Daylight plane shall not be enforced for an ADU if the structure abuts a city street or alleyway in the rear of the property.

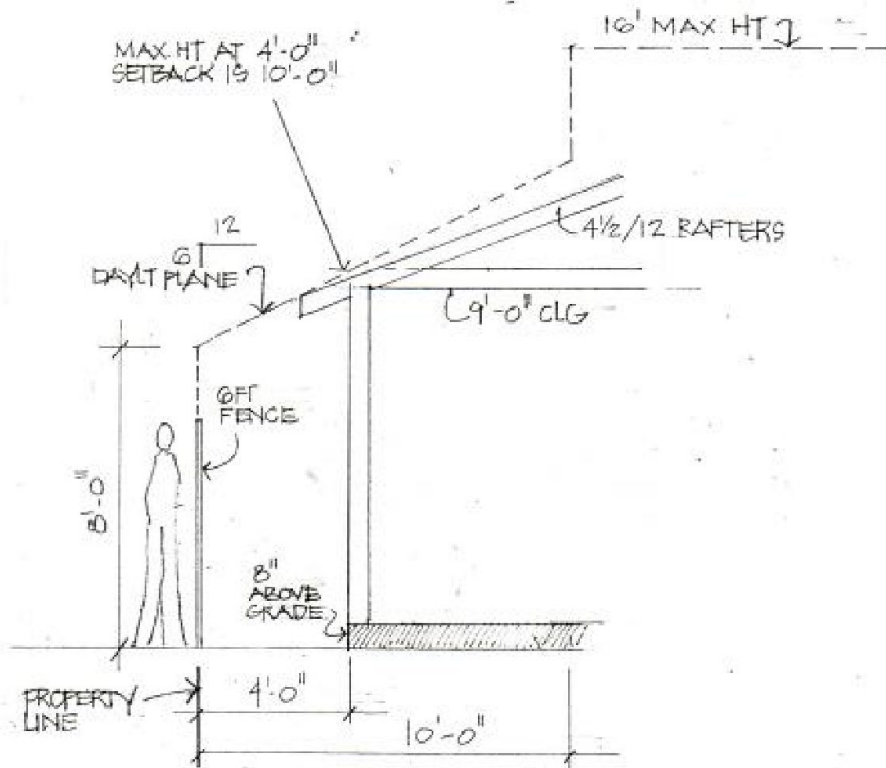

(h) A single-family residential accessory dwelling unit must be built in accordance with the building code set forth in Title 12, except that any design, zoning, and building standards inconsistent with state requirements under California Government Code Section 65852.2 shall not apply.

(i) Parking. One (1) additional uncovered parking space of nine feet by eighteen feet (9X18) shall be required for a newly constructed single-family residential accessory dwelling unit, which may be located within the front setback, in tandem and in an existing driveway including within an interior side yard setback area, unless a specific finding is made that such parking is not feasible due to specific site, topographical or fire and life safety. Notwithstanding the above, a parking stall will not be required for a residential accessory dwelling unit that meets any of the following criteria:

- (1) The single-family residential accessory dwelling unit is created as a result of the conversion of existing area of the single-family residence or existing permitted residential accessory structure.
- (2) An existing garage, carport or parking structure is converted or demolished to accommodate a single-family residential accessory dwelling unit in the same location.
- (3) The single-family residential accessory dwelling unit is within one-half (1/2) mile walking distance of a public transit station, such as a bus stop or train station.
- (4) The property is within an architecturally and historically significant historic district.

(5) On-street parking permits are required in the area but not offered to the occupant of the residential accessory dwelling unit.

(6) A vehicle share site is located within one (1) block of the single-family residential accessory dwelling unit.

(j) Design Standards. Architectural review of attached or detached single-family residential accessory dwelling units over 851 square feet or greater will be limited to the following:

(1) Notwithstanding any other provision of this code, a zoning clearance letter shall be issued for accessory dwelling units and shall be reviewed by the director of community development or their designee for compliance with objective design standards as identified within Chapter 14.06(Single Family Zoning Districts or Chapters 14.16-14.24 (Multi Family Zoning Districts)). The permit shall be considered ministerial without discretionary review within the time frames required by Section 65852.2 of the Government Code; when the application is in compliance with the relevant standards, the permit shall be issued.

(2) In those instances where an applicant seeks permission to deviate from the standards, a variance shall be filed in accordance with 14.76.070. If the permit application to create an accessory dwelling unit or a junior accessory dwelling unit is submitted with a permit application to create a new single-family dwelling on the lot, the City may delay acting on the permit application for the accessory dwelling unit or the junior accessory dwelling unit until the permitting agency acts on the permit application to create the new single-family dwelling, but the application to create the accessory dwelling unit or junior accessory dwelling unit shall be considered without discretionary review or hearing. If the applicant requests a delay, the 60-day time period shall be suspended for the period of the delay.

(3) The architectural features, window styles, roof slopes, exterior materials, colors, appearance, and design of the single-family residential accessory dwelling unit must be compatible with the existing single-family dwelling.

(4) Minimum sill height of 5' (60) inches for windows on the second story within 15' of the property line that face out to the neighbors to try to mitigate privacy concerns shall be required.

(5) A new single-family residential accessory dwelling unit located within a historic site or neighborhood combining district will be subject to ministerial review for compliance with the design review criteria set forth in section Chapter 12.44 of the Los Altos Municipal Code and must be consistent with the Secretary of Interior's Standards for the Treatment of Historic Properties.

(6) Outside stairways serving a second story single-family residential accessory dwelling unit shall not be constructed on any building elevation facing a public street.

(7) No passageway will be required in conjunction with the construction of any single-family residential accessory dwelling unit.

(k) Streamlined Approval of Accessory Dwelling Units. Notwithstanding the restrictions above, a building permit application for a detached, single-family residential accessory dwelling unit within a residential or mixed-use zone must be a ministerial approved if it is:

- (1) Setback four (4) feet from the interior side and rear lot lines.
 - (2) No larger than eight hundred and fifty (850) square feet in floor area; and
 - (3) No taller than sixteen (16) feet in height.
- (l) Annual recertification. On an annual basis property owners will provide City staff access to the accessory dwelling unit to ensure compliance with the approved plans and voluntarily submit rental data for use by the City for the City's Regional Housing Needs Allocation

14.14.060 Junior accessory dwelling unit standards.

Notwithstanding any other provisions in this Article or of this chapter to the contrary, a junior accessory dwelling unit shall be permitted and comply with the following:

(a) Owner-occupancy of the property shall be required for junior accessory dwelling units or the main dwelling unit. The owner may reside in the primary residence, junior accessory dwelling unit or separate residential accessory dwelling unit constructed on the property in compliance with this Article.

(b) One (1) junior accessory dwelling unit may be permitted per residential lot zoned for a single-family residential use, provided that the lot has not more than one (1) existing or proposed single-family residence. A single-family residential lot is allowed to have both one

(1) junior accessory dwelling unit and one detached accessory dwelling unit.

(c) The unit must be constructed within the existing walls of a single-family dwelling except that an expansion of 150 square feet beyond the existing physical dimensions of the accessory structure may be permitted to accommodate required ingress and egress.

(d) The square footage of the unit shall be at least the minimum size (150 square feet) required for an efficiency unit, up to a maximum size of five hundred (500) square feet in floor area, and must include one bedroom or studio sleeping area.

(e) A separate entrance from the unit to the exterior of the residence, and an interior connection to the main living area may be provided. A second interior doorway for sound attenuation may also be permitted.

(g) At least an efficiency kitchen must be provided in the unit which shall include all of the following:

(1) A cooking facility with appliances. Appliances can include hot plate, or counter top cooking. A property owner does not need to a wall installed oven or stove to qualify for a cooking appliances.

(2) A food preparation counter and storage cabinets that are of reasonable size in relation to the size of the junior accessory dwelling unit.

(h) The unit may include separate bathroom facilities or may share bathroom facilities contained within the primary residence.

(i) No separate utility connection, connection fee or capacity charge, or parking space shall be required for a junior accessory dwelling unit.

(j) a deed restriction shall be required for junior accessory dwelling units and must include the following stipulations:

(1) prohibition on the sale of the JADU separate from the sale of the single family residence

(2) if a JADU is rented, the unit shall not be rented for a period of less than thirty (30) consecutive days

(3) owner occupancy is required for the JADU or the main house, unless the owner is another government agency, land trust or housing organization as allowed by State Law.

(k) Annual recertification deed restriction. On an annual basis property owners will provide City staff access to the accessory dwelling unit to ensure compliance with the approved plans and voluntarily submit rental data for use by the City for the City's Regional Housing Needs Allocation.

14.14.070 Multi-family accessory dwelling unit Standards.

Notwithstanding any other provisions of this chapter to the contrary, multi-family accessory dwelling units shall be permitted and comply with the following:

(a) The type of ADUs described in the single-family portion of the ordinance may also be built on a multifamily site if so desired.

(b) Portions of existing multi-family dwelling structures that are not used as livable space (including, but not limited to, storage rooms, boiler rooms, passageways, attics, basements, or garages), may be converted for use as accessory dwelling units provided that total number of units must not exceed twenty-five (25) percent of the existing multi-family dwelling units or one (1) unit, whichever is greater.

(c) An owner may also construct up to a maximum of two detached accessory dwelling units on a lot that has an existing multifamily dwelling, subject to a height limit of sixteen (16) feet and four (4) foot rear yard and side setbacks. If there are inconsistencies between this Chapter and other provisions of the Los Altos municipal code, this Chapter shall prevail over those other provisions.

(d) Accessory dwelling units in multi-family zone districts shall comply with Government Code Section 65852.2.

(e) Annual recertification. On an annual basis property owners will provide City staff access to the accessory dwelling unit to ensure compliance with the approved plans and voluntarily submit rental data for use by the City for the City's Regional Housing Needs Allocation.

14.14.080 Voluntary Additional Setback

For a detached accessory dwelling unit, the minimum setbacks shall be five feet (5) from the house, and four feet (4) from the side yard and rear yard setbacks. However, so as to reduce the privacy impacts to abutting property owners, applicants are encouraged to voluntarily increase the setbacks to be ten (10) feet from the rear yard and eight feet (8) from the interior side yard.

14.14.090 Voluntary Annual ADU Recertification Process

City staff are directed to send out an annual ADU rental income survey to be released no later than September 1st of every calendar year. The property owner can voluntarily share the rental income for the unit with the City for purposes of Los Altos meeting its Regional Housing Needs Allocation (RHNA) Housing Element figures.

SECTION 2. CONSTITUTIONALITY. If any section, subsection, sentence, clause or phrase of this code is for any reason held to be invalid or unconstitutional, such decision shall not affect the validity of the remaining portions of this code.

SECTION 3. CEQA. The City Council finds the adoption of this ordinance to be statutorily exempt from the requirements of the California Environmental Quality Act (CEQA) pursuant to Section 21080.17 of the Public Resources Code because it is an ordinance regarding second units in single-family and multifamily residential zones to implement the provisions of Government Code Section 65852.2.

SECTION 4. PUBLICATION. This ordinance shall be published as provided in Government Code section 36933. Within 15 days of the passage of this ordinance, the City Clerk shall cause the full text of the ordinance, with the names of those City Council members voting for and against the ordinance, to be published in an adjudicated newspaper. In lieu of publishing the full text of the ordinance, the City Clerk, if so directed by the City Attorney and within 15 days, shall cause a summary of the ordinance, prepared by the City Attorney and with the names of the City Council members voting for and against the ordinance, to be published in an adjudicated newspaper, and shall post in the office of the City Clerk a certified copy of the full text of the ordinance, along with the names of those City Council members voting for and against the ordinance. The publication of a summary of the ordinance in lieu of the full text of the ordinance is authorized only where the requirements of Government Code Section 36933(c)(1) are met.

SECTION 5. EFFECTIVE DATE. This ordinance shall be effective upon the commencement of the thirty-first day following the adoption date.

SECTION 6. TRANSMISSION TO HCD. The City Clerk shall send a certified copy of this ordinance to the Department of Housing and Community Development (HCD) within sixty (60) days after adoption, as required by state law.

The foregoing ordinance was duly and properly introduced at a regular meeting of the City Council of the City of Los Altos held on _____, 2020 and was thereafter, at a regular meeting held on _____, 2020 passed and adopted by the following vote:

AYES:
NOES:
ABSENT:
ABSTAIN:

Janis C. Pepper, MAYOR

Attest:

Jon Maginot, CMC, CITY CLERK

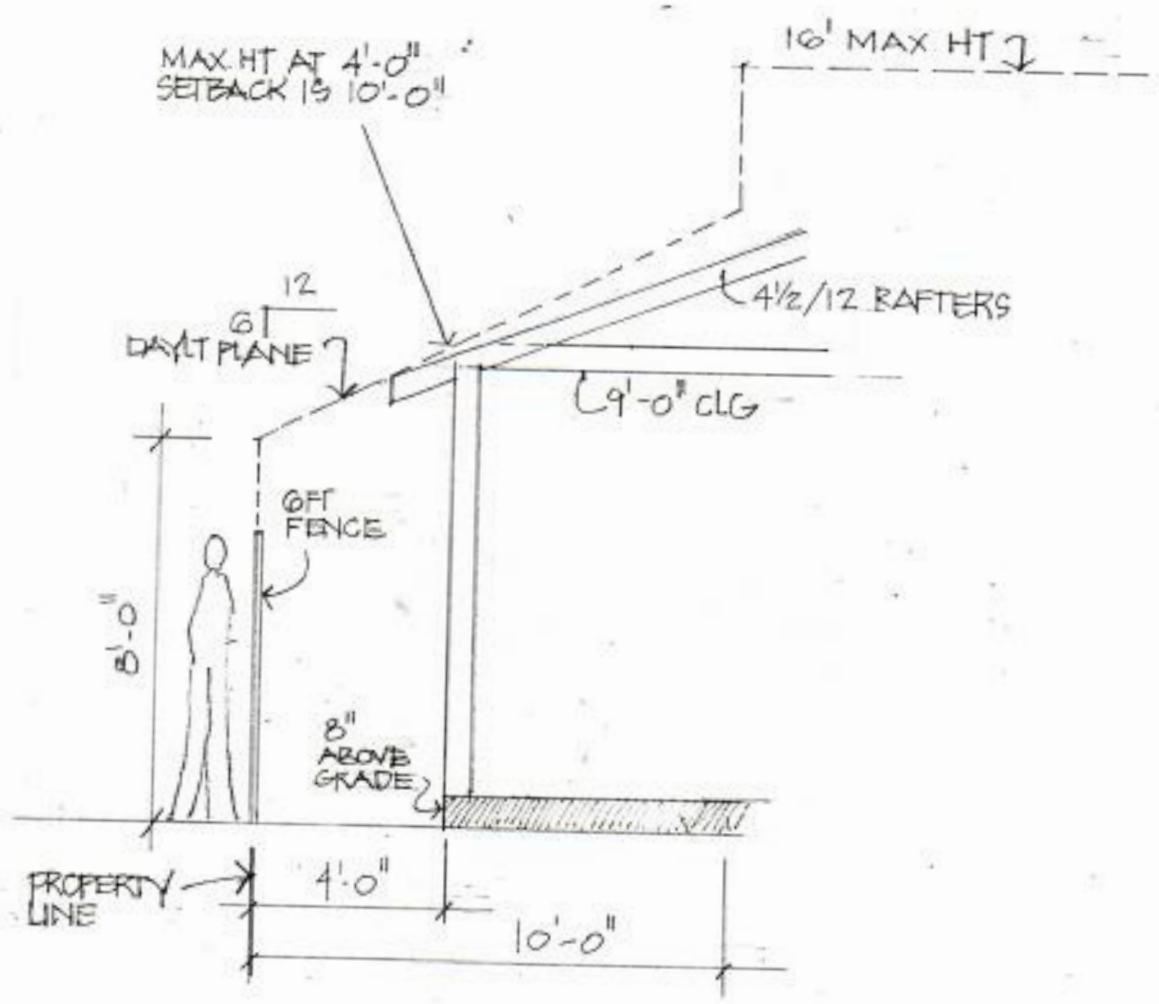

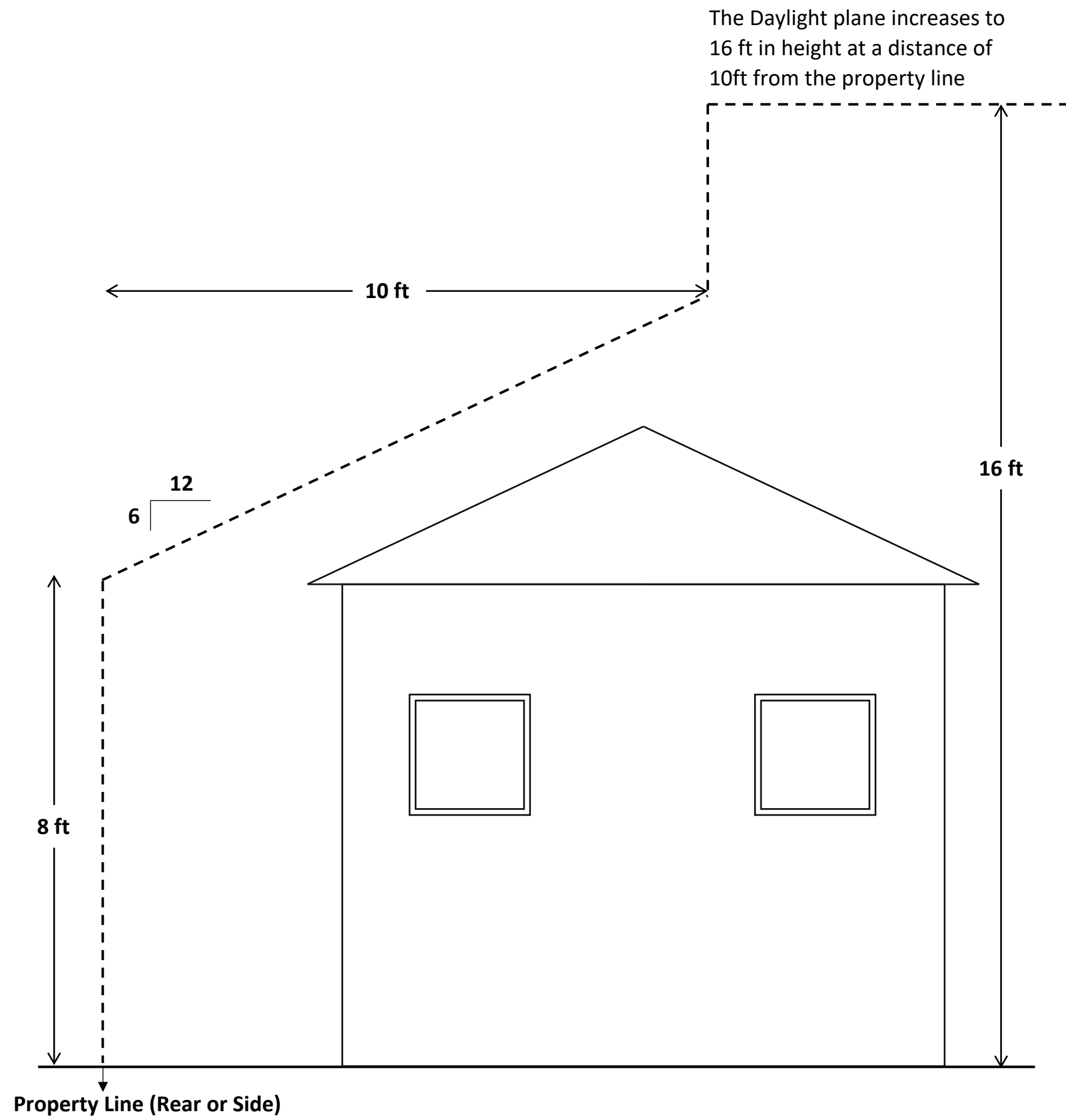

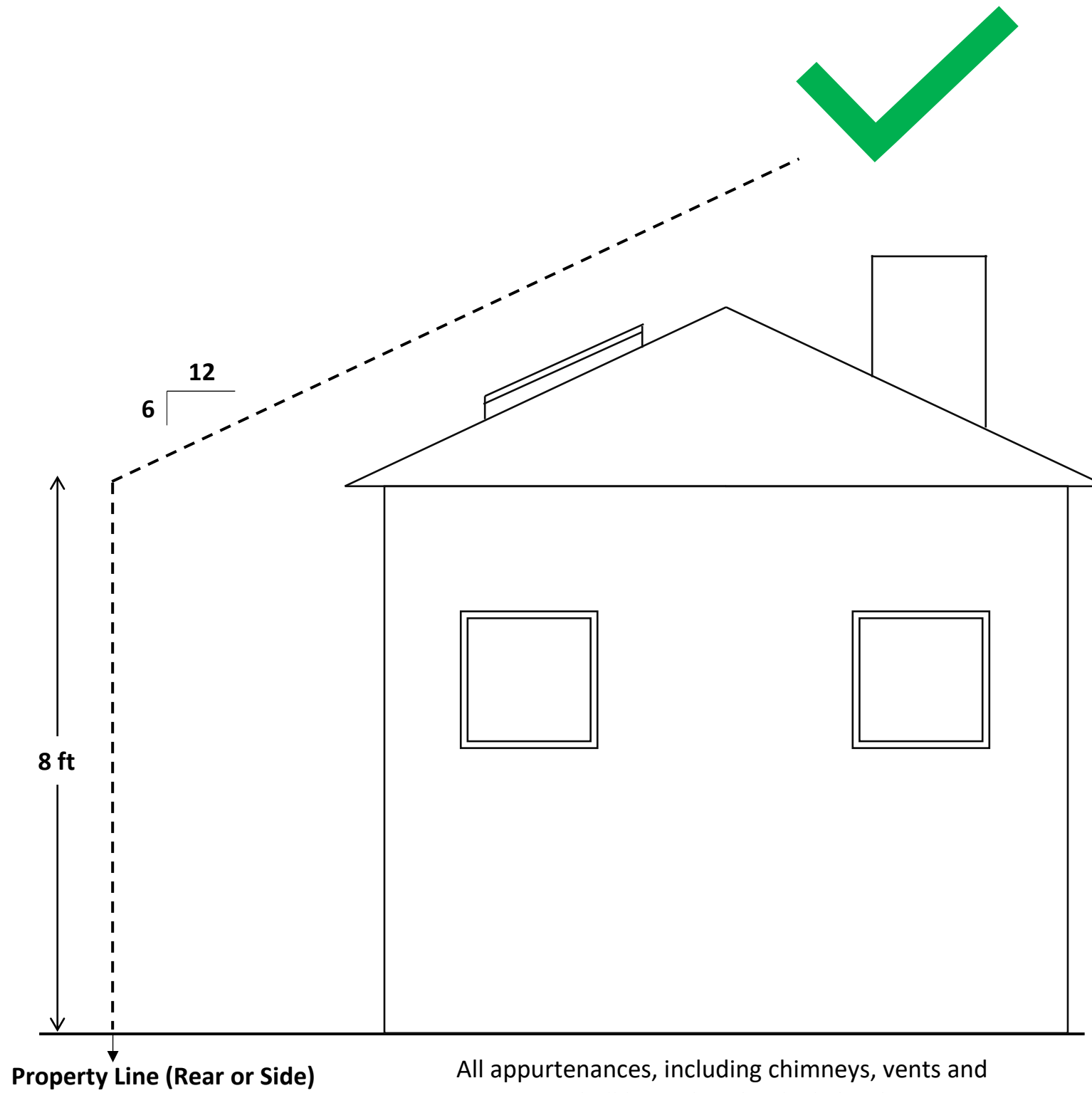

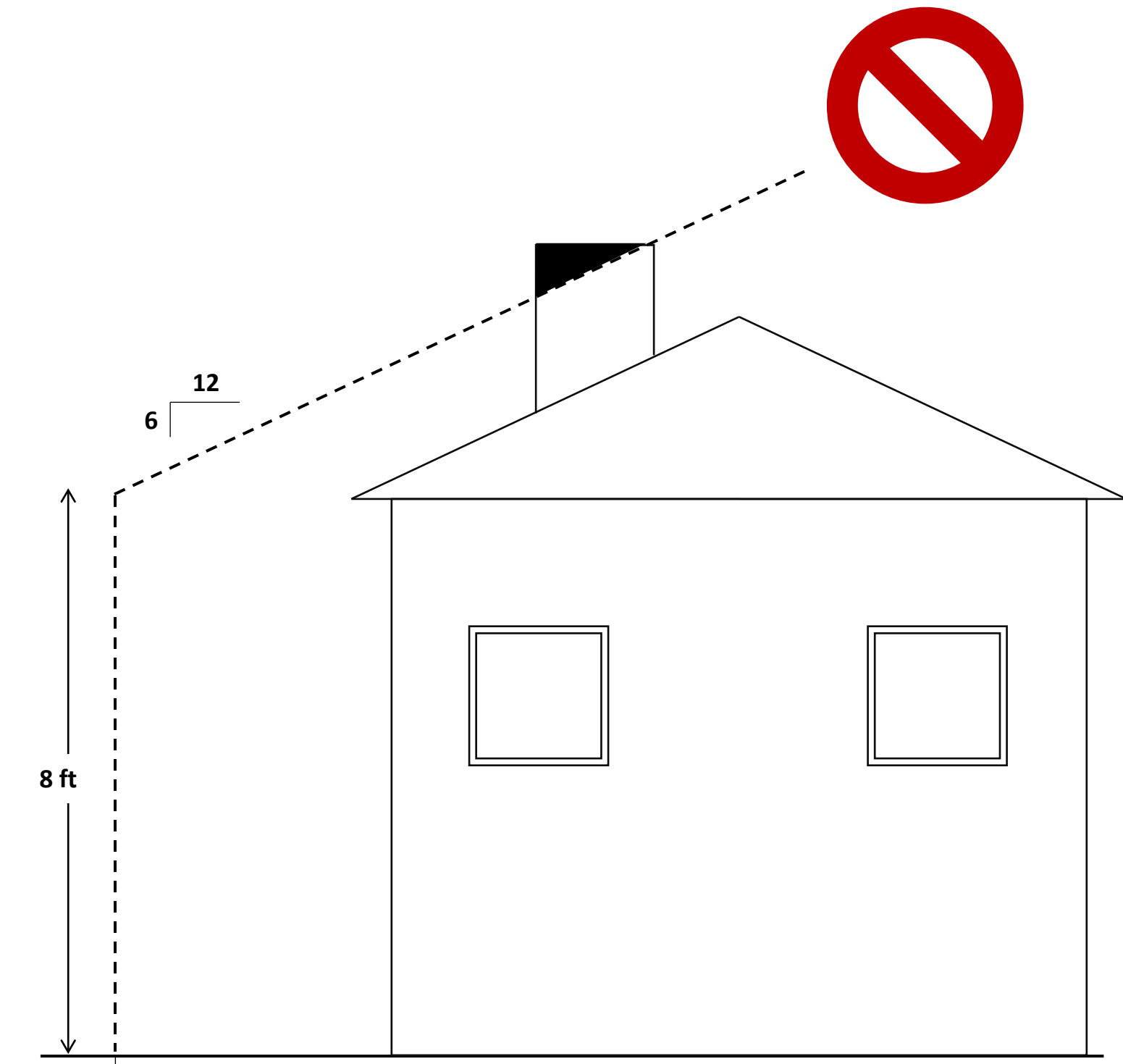

Property Line (Rear or Side)

All appurtenances, including chimneys, vents and antennas, shall be within the daylight plane.



May 21, 2020

VIA EMAIL

Planning Commission
City of Los Altos
1 North San Antonio Road
Los Altos, CA 94022
Email: planningcommission@losaltosca.gov

RE: May 21, 2020 Planning Commission Meeting, Agenda Item 2

To the Planning Commission:

As you know, Californians for Homeownership is a 501(c)(3) non-profit organization devoted to using legal tools to address California's housing crisis. This letter follows up on our prior letters providing feedback on the City's draft ADU ordinance. At your May 21 meeting, you will again review the ordinance, which continues to suffer from very serious defects.

The problems include:

- The draft ordinance appears to prohibit the development of ADUs under Government Code Section 65852.2(a) in connection with multifamily structures, by limiting ADUs under proposed Municipal Code Section 14.14.050 to the single-family context. While it is true that many owners of multifamily buildings will choose to develop multiple ADUs under Sections 65852.2(e)(1)(C) and (D), an applicant may instead choose to develop a single ADU under Section 65852.2(a)—for example, through the conversion of existing livable space. As of January 1, 2020, subdivision (a) has been modified to replace references to “single-family dwelling” with “primary dwelling.”

- The draft ordinance limits detached ADUs to 50% of the size of the primary dwelling. The 50% limit only applies to attached ADUs, not to detached ADUs. *See* Gov. Code § 65852.2(a)(1)(D)(iv). Detached ADUs must be allowed up to 1,000 square feet (for ADUs with two or more bedrooms). Gov. Code § 65852.2(c)(2)(B).

- The draft ordinance defines “attached” ADUs to include internal ADUs, and purports to apply a maximum unit size to such ADUs. Because an interior ADU will always qualify for mandatory approval under Section 65852.2(e) regardless of local standards, from a practical perspective, the City will never be allowed to apply its maximum unit size to an interior ADU.

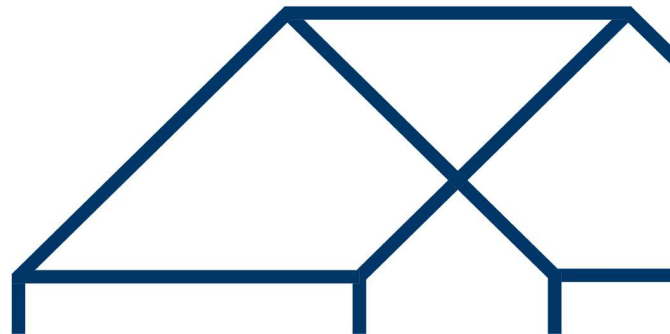

May 21, 2020

Page 2

- The draft ordinance prohibits ADUs from “encroach[ing] upon the . . . side yard-area.” This is a setback requirement, and is subject to the state law limits on setbacks for ADUs. *See* Gov. Code § 65852.2(a)(1)(D)(vii).

- The draft ordinance only applies the state law 4-foot setback maximums to detached ADUs. State law overrides larger setbacks for all ADUs. Gov. Code § 65852.2(a)(1)(D)(vii).

- The requirement for a property owner to acknowledge that the elimination of parking constitutes a “nonconformity” is unlawful and inappropriate. The development of an ADU does not create a zoning nonconformity, because an ADU permitted under state law (including a garage conversion) is “deemed to be a residential use that is consistent with the existing general plan and zoning designations for the lot.” Gov. Code § 65852.2(a)(8). The parking replacement rule in state law reflects the Legislature’s deliberate decision to override local parking requirements.

- Proposed Municipal Code Section 14.14.070 appears intended to account for the streamlined ADU categories described in Government Code Sections 65852.2(e)(1)(C) and (D). But it improperly prohibits the conversion of “any residential amenities required to be provided for the facility by the zoning ordinance, or as a condition of project approval.” California is in the midst of a housing crisis of historic proportions, and ADUs are a critical part of the Legislature’s effort to address that crisis. *See* Gov. Code § 65852.150(a). The purpose of Section 65852.2(e)(1)(C) is to substitute the Legislature’s preference for housing for local governments’ preference for providing non-housing residential amenities, such as storage areas.

- Proposed Municipal Code Section 14.14.070 also improperly requires these ADUs to comply with “all the objective standards of the zone district they are located in unless inconsistent with the standards provided in this Chapter.” All Section 65852.2(e)(1) ADUs must be permitted regardless of any local standards other than those specifically allowed by Section 65852.2(e).

We urge you to direct staff to make changes to address these concerns.

Sincerely,



Matthew Gelfand

cc: City of Los Altos

Guido F. Persicone, Planning Services Mgr. (by email to [gpsicone@losaltosca.gov](mailto:gpersicone@losaltosca.gov))

Jon Biggs, Community Development Director (by email to jbiggs@losaltosca.gov)

Chris Jordan, City Manager (by email to cjordan@losaltosca.gov)

Jolie Houston, Esq., City Attorney (by email to jolie.houston@berliner.com)

California Department of Housing and Community Development

Greg Nickless, Housing Policy Analyst (by email to greg.nickless@hcd.ca.gov)

ATTACHMENT D

From: Miller_Reid@HCD
To: [Guido Persicone](#)
Subject: Brief Comments on Californians for Homeownership Letter
Date: Tuesday, June 2, 2020 3:43:07 PM
Attachments: [Example Language For Government Code Section 65852.docx](#)

Hi Guido,

Thanks again for reaching out to us about comments to your ordinance. I'm sorry for the delay in our response, but with our offices being completely closed these past few days, I haven't really been able to communicate at all with Greg on this. If you would like, we can set up a phone call tomorrow and hopefully discuss all this with Greg present, but here are my initial suggestions:

1. I think Matt is right as far as allowing the types of ADUs under (a) on lots with multifamily. While the requirements under (e) specifically address what must be allowed on lots with a multifamily dwelling, it does not preclude the types of ADUs described in (a)-(d). Perhaps just add a subsection to 14.14.070 to state that the type of ADUs described in the single-family portion of the ordinance may also be built on a multifamily site if so desired.
2. Matt is also correct that the 50% square footage only applies to attached ADUs within the primary dwelling when the maximum size is determined by a percentage, FAR, etc. Detached ADUs could be up to 850 square feet for a one-bedroom or 1,000 square feet for two bedrooms. This language would need to be changed in your tables and in the text under 14.14.050(d)(i)-(ii)
3. I'm not totally clear on the "internal"/"attached" comment from Matt, but I believe he is correct in stating that if an internal ADU is applied for under (e), there is no maximum size limit that can be applied, and it would thus have to be approved. That information would need to be added in under 14.14.050(k).
4. I'm also not exactly sure which section Matt is referring to for the ADUs not being allowed to encroach upon the side yard area, but just as a reminder, all ADUs are subject to setbacks of no greater than 4 feet.
5. I do agree as well that the notarized letter described in 14.14.050(i)(2) goes too far, as it seems to act as a way to skirt the fact that ADUs created in conformity with State ADU Law are deemed consistent with the existing general plan and zoning designations for the lot. I would remove that requirement from the ordinance.
6. The last two bullet points are just a reminder that local standards other than those specifically called out in CA Gov Code 65852.2(e) must not be applied to ADU applications filed under that subdivision. I know it's a bit confusing, but this is just an extra layer of streamlining that would not apply under 65852.2(a)-(d). I have attached some template language for an added streamlining section should you want to use it.

Also, just a quick question, is this the same ordinance that I reviewed a few weeks ago? there are pieces I recognize, but some elements I don't remember seeing. I don't remember the parking requirement nonconformity acknowledgment for example, but maybe I just didn't review it as closely as I could have...

Hope these suggestions help, and if you have any additional questions, or would like to set up a time to discuss tomorrow, just let me know!

Best,

Reid



ITEMS FOR DISCUSSION/ACTION Agenda Item # 2
--

AGENDA REPORT SUMMARY

Meeting Date: May 21, 2020

Subject: Repeal and Replace Chapter 14.14 of the Los Altos Municipal Code (Accessory and Junior Dwelling Units) by adopting Zoning Text Amendment 20-0001

Prepared by: Guido F. Persicone, Planning Services Manager, AICP

Reviewed by: Jon Biggs, Community Development Director and
Jolie Houston, City Attorney

Attachment(s):

- A. Draft ADU Ordinance
- B. Voluntary Daylight Plane Provisions

Initiated by:

City staff

Previous Council Consideration:

2018

Fiscal Impact:

No direct fiscal impact is anticipated

Environmental Review:

Adoption of an accessory dwelling unit ordinance is subject to a statutory exemption from environmental review (Public Resource Code Section 15282(h)). In addition, the action being considered does not constitute a “project” within the meaning of the California Environmental Quality Act (“CEQA”) pursuant to CEQA Guidelines Section 15061(b)(3) as the activity is covered by the general rule that CEQA applies only to projects which have the potential for causing a significant effect on the environment. Where it can be seen with certainty that there is no possibility that the activity in question may have a significant effect on the environment, the activity is not subject to CEQA. Projects that are subject to the ADU regulations will be evaluated pursuant to CEQA on an individual basis. However, ADUs are generally exempt from CEQA review under CEQA Guidelines Section 15301 (Existing Facilities) and/or Section 15303 (New Construction or Conversion of Small Structures).

Policy Question(s) for Council Consideration:

- Do the proposed code amendments ensure the Los Altos Municipal Code is consistent with recent changes to state law?



Subject: Proposed Amendments to the Chapter 14.14 (Accessory Dwelling Unit) Ordinance
Second Planning Commission Meeting

Summary:

- The ordinance repeals and replaces Chapter 14.14, Accessory Dwelling Units, to ensure consistency with State law.

Staff Recommendation:

Staff suggests that the Planning Commission recommend adoption of the proposed ordinance to the City Council.

Purpose

The purpose of the proposed amendments is to ensure compliance with new state laws affecting the development of accessory dwelling unit and junior accessory dwelling units in the residential zone districts of the City.

Background

On April 16, 2020 the Planning Commission reviewed the draft accessory dwelling unit ordinance (ADU). At the conclusion of the meeting, the Commission requested that the ordinance be revised and be reviewed by the legislative body at the May 7, 2020 meeting.

In addition to the Commission's edits, on the day of the hearing the State Housing and Community Development Department (State HCD) reached out to City staff to provide some direction on edits that would be necessary to receive State support for the draft ordinance. This was extremely helpful as State approval within sixty (60) days of adoption is a legal requirement from the most recent legislation.

On May 7, 2020, the Planning Commission reviewed the draft ordinance and directed staff to bring the ordinance back for review at the May 21, 2020 meeting. Below is a summary of the modifications made:

Categories of ADU-A chart has been added to the ordinance to summarize the key standards that apply to the various types of ADU's in the new regulations.

Section 14.14.021 (Square Footage Chart)-The Planning Commission requested that City staff revise the square footage chart identified within Section 14.14.025 of the draft ordinance. Said modifications have been made.

Daylight Plane Provisions-At the May 7, 2020 meeting the Planning Commission modified the daylight plane provisions to start at eight feet above the property line and slope in at a 6/12 roof pitch. At ten feet from the property line the maximum height of 16 feet would be allowed.



Subject: Proposed Amendments to the Chapter 14.14 (Accessory Dwelling Unit) Ordinance
Second Planning Commission Meeting

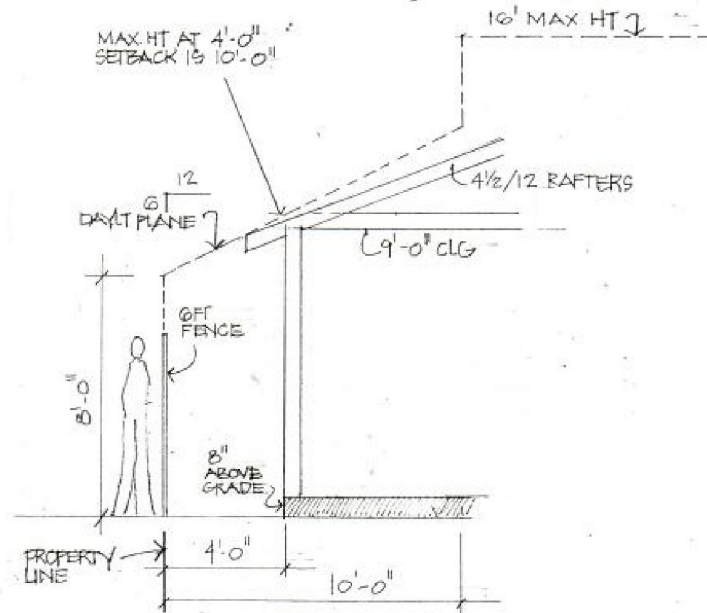

50% Rule-City staff kept this provision in the proposed ordinance because it was thoroughly discussed by the City Council during the last ADU ordinance update. It should be noted this ordinance has two key parts:

Subsection i) related to an **attached** ADU, in which case the basement is not included in the square footage. This is done because per the definition of gross floor area within the Los Altos Muni Code, basements are not counted toward the allowable floor area ratio for a property

- (i) *The total floor area for an attached accessory dwelling unit shall not exceed one thousand two hundred (1,200) square feet, excluding the basement areas, and shall not be more than fifty (50) percent of the floor area of the existing or proposed principal residence. Notwithstanding this 50% threshold requirement, an ADU of 850 square feet or smaller cannot be denied.*

Subsection ii) which relates to a **detached** ADU, in which case the City Council wanted to presumably limit the size of said units by including the square footage of basements in this definition.

- (ii) *The total floor area for a detached accessory dwelling unit shall not exceed one thousand two hundred (1,200) square feet, including basement areas of the detached unit, and shall not be more than fifty*



Subject: Proposed Amendments to the Chapter 14.14 (Accessory Dwelling Unit) Ordinance
Second Planning Commission Meeting

(50) percent of the floor area of the existing or proposed principal residence. Notwithstanding this 50% threshold requirement, an ADU of 850 square feet or smaller cannot be denied.

In either scenario State HCD wanted it to be very clear that at least an 800 square foot ADU (either attached or detached) would be allowed on a property, regardless of the 50% rule within this ordinance. However, as the distinction between an 800 and 850 square foot unit is negligible and has caused confusion among members of the public, City staff along with the City Attorney are recommending that up to 850 square feet be allowed for an ADU on a site that is at or in excess of lot coverage and floor area standards, with the words up to meaning an applicant can create a unit smaller but the City must grant up to 850 square feet for the ADU if desired by the property owner. After Planning Commission review, the entire ordinance will be reviewed by State HCD, but presumably will be supported as the 850 sq. ft. is above the 800 sq. ft. mandated by State law.

Fees-In light of the regional housing crisis, reducing fees for all accessory dwelling units (ADUs) is a concrete step Los Altos could take to demonstrate to the community and the California Department of Housing and Community Development (State HCD) that Los Altos wants to encourage production of these units. No final direction was provided to staff regarding potential reduction of said fees. At the conclusion of the May 21, 2020 meeting, City staff are requesting that the motion for the zoning text amendment to the City Council include a recommendation either in the affirmative, namely reduction of fees, or in the negative (to keep fees as identified in the Master Fee Schedule).

Hybrid Model - During the April 23rd and May 7th Commission meetings members of the public provided a possible scenario in which a property owner could take square footage already existing in a house (500 square feet) have it refurbished for an ADU and then add 350 square feet for an 850 square foot ADU. This suggestion was to then take the 500 square feet used for the ADU and add this area to another portion of the house with the end result the same square footage allowable for the lot.

Table 1 (Hybrid Scenario)	
3800 square foot max for a house	3,300 main house
850 square foot max for an ADU	+500 square foot ADU remodel with a 350 sq. ft. addition) +500 for another addition to the house
Total=4,560 total square feet	Total 4,650 total square feet.

The Planning Commission inquired if this would require a revision to the ordinance to create a new subclass of ADUs. The City staff answer is no as this would still be classified as an attached ADU. This is a policy recommendation that City staff is not going to take a position on. On one hand, it



Subject: Proposed Amendments to the Chapter 14.14 (Accessory Dwelling Unit) Ordinance
Second Planning Commission Meeting

makes sense that the amount of square footage would be the same and could create a better integrated attached ADU. On the other hand, it could be a potential way to circumvent the floor area ratio caps within the Municipal Code. Additionally, constant monitoring of this could be problematic. Under this scenario, a property owner could take out the kitchen, and separate bathroom facilities after approval by the City. Without monitoring, property owners could essentially be granted houses that exceed the allowable floor area ratio for a property while not meeting the real intent of the ADU legislation, which is to foster the development of units to help ease the affordable housing crisis.

However, having said all of that, in conversations with the 21 Elements Group and the City of Hillsborough, the City of Los Altos can receive Housing Element RHNA credit if it monitors the rent of ADUs moving forward. Hillsborough through submittal of a voluntary survey receives RHNA credits for its low and very low income units. Deed restrictions are not required. If the Planning Commission and City Council want to move forward with this hybrid approach, a policy compromise could be provided to allow this integrated approach but to require property owners to pay an annual inspection fee and to report the rental income data for the all ADUs within Los Altos.

Regional Housing Needs Allocation (RHNA) and ADUs

Hillsborough-On May 5, 2020 Los Altos city staff spoke with Liz Ruess, Hillsborough Planning Manager. Hillsborough gets credit for their ADUs at the low and very low income RHNA levels. Every year they send out a survey and property owner self-report the rent for the unit. Liz indicated they get about a 50% response rate for the survey that is sent out.

Half Moon Bay-City staff spoke with Scott Phillips from Half Moon Bay (HMB). HMB, similar to Hillsborough, collects rent data from property owner and then receives credit for their units as being moderate income ADUs.

The approach that Hillsborough and Half Moon Bay have taken to gather information to support meeting their RHNA goal is supported by State HCD per a memo prepared by the 21 Elements Group: <http://21elements.com/documents-mainmenu-3/housing-elements/rhna-5-2014-2022/sites-inventory/655-affordability-of-second-units>

Los Altos should begin a process of collecting ADU data to support meeting our long term RHNA goals. City staff are requesting that as part of the motion to approve the Zoning Text Amendment that the Planning Commission also encourage the City Council to adopt a resolution creating an annual ADU Recertification Program supported by payment of an annual inspection fee from property owners.



Subject: Proposed Amendments to the Chapter 14.14 (Accessory Dwelling Unit) Ordinance
Second Planning Commission Meeting

Conclusion

The Planning Commission has asked City staff a lot of great questions and really forced members of the community to think about the overall intentions of implementing these state laws. As of January 1, 2020, state laws regarding ADUs prevail, without a daylight plane and other characteristics unique to Los Altos. City staff are recommending a vote on the ordinance, so the City Council has an opportunity to deliberate to maintain some semblance of local land use control for ADUs moving forward.

Los Altos General Plan Conformance

General Plan Land Use Goal 2: Review and amend (as needed) the Zoning Ordinance to provide consistency with new state legislation and court decisions. Consider Zoning Ordinance amendments that implement the use and development of goals, policies and plan objectives for the identified planning areas (Downtown, El Camino Real Corridor, and Foothill Plaza).

Housing Element Policy 4.2: The City will encourage the development of affordable second dwelling units that conform to zoning regulations.

Program 4.2.1 – Facilitate new construction of second dwelling units.

Program 4.2.2-Study the feasibility of reducing minimum lot sizes for second living units.

Options

- 1) Recommend approval of Zoning Text Amendment 20-0001 to the City Council.

Advantages: Ensure compliance with new state laws.

Disadvantages: Results in less control over accessory dwelling units in Los Altos.

- 2) Recommend denial of the draft ordinance to the City Council

Advantages: There is no advantage to denying this ordinance as noncompliance with State law is not a viable position for a municipal agency to be in.

Recommendation

The staff recommends Option 1.

ORDINANCE NO. 2020-___

**AN ORDINANCE OF THE CITY COUNCIL OF THE CITY OF LOS ALTOS
REPEALING AND REPLACING THE ACCESSORY DWELLING UNIT
ORDINANCE AND MAKING FINDINGS OF CEQA EXEMPTION**

WHEREAS, the State Legislature has found that accessory dwelling units are a necessary and valuable form of housing in California; and

WHEREAS, accessory dwelling units help diversify the City's housing stock and help provide rental units that are affordable; and

WHEREAS, accessory dwelling units offer lower cost housing to meet the needs of existing and future residents within existing neighborhoods, while respecting neighborhood character; and

WHEREAS, accessory dwelling units provide housing for family members, students, the elderly, in-home health care providers, the disabled, and others within existing neighborhoods; and

WHEREAS, it is the intent of this ordinance to allow and promote the development of accessory dwelling units; and

WHEREAS, this Ordinance implements Program 4.2.1 and Program 4.2.2 of the City's 2015-2023 Housing Element by facilitating the development of new accessory dwelling units; and

WHEREAS, this Ordinance is exempt from environmental review pursuant to Section 15061 and Section 15301 of the California Environmental Quality Act Guidelines, as amended.

NOW THEREFORE, the City Council of the City of Los Altos does hereby ordain as follows:

SECTION 1. AMENDMENT OF CODE: Chapter 14.14 of Title 14 of the Los Altos Municipal Code is hereby repealed in its entirety and replaced with the new standards and shall read as follows:

Section 14.14.010 Purpose and Intent.

The intent of this chapter is to provide for accessory dwelling units and junior accessory dwelling units, collectively known as an accessory dwelling, on lots zoned to allow single-family or multifamily dwelling residential use that include a proposed or existing dwelling. Accessory dwelling units contribute needed housing to the City of Los Altos housing stock and enhance housing opportunities. An accessory dwelling unit is considered a residential use that is consistent with the existing general plan and zoning designations for the lot. The accessory dwelling unit is not included in calculation of residential density for the purposes of determining general plan conformance.

14.14.020 Definitions.

As used in this section, the following terms mean:

“Accessory dwelling unit” (or “ADU”) means an attached or a detached residential dwelling unit that provides complete independent living facilities and is located on a lot with a proposed or existing primary residence. It shall include permanent provisions for living, sleeping, eating, cooking, and sanitation on the same parcel as the single-family or multi-family dwelling is or will be situated. An accessory dwelling unit also includes the following:

(A) An efficiency unit, as defined in Section 17958.1 of the Health and Safety Code.

(B) A manufactured home, as defined in Section 18007 of the Health and Safety Code.

“Attached accessory dwelling unit” means a residential dwelling unit that is created as a result of internal conversion, addition, or combination thereof made to the primary residential dwelling unit.

“Existing,” when referring to an existing principal dwelling, accessory structure, or other building or structure, refers to a building or structure erected prior to the date of adoption of the appropriate building code, or one for which a legal building permit has been issued, as defined in Section 202 of the 2019 California Building Code. An unpermitted building or structure shall not be considered “existing” for purposes of this chapter.

“Multi-family housing” means a dwelling unit or group of dwelling units on one site that contains separate living units for two or more families that may have joined services or facilities or both.

“Junior accessory dwelling unit” (or “junior ADU” or “JADU”) means a unit that is no more than 500 square feet in size, includes an efficiency kitchen consistent with building code standards, is contained entirely within the walls of a single-family residence and may include separate sanitation facilities or may share sanitation facilities with the existing structure or unit.

“Living area” means the interior habitable area of a dwelling unit, including basements and attics, if defined as habitable by the California Residential Code (CRC) but does not include a garage or any accessory structure.

“Nonconforming zoning condition” means a physical improvement on a property that does not conform with current zoning standards.

“Passageway”. The term passageway has the meaning defined by Government Code Section 65852.2, which states: A pathway that is unobstructed clear to the sky and extends from a street to one entrance of the accessory dwelling unit.

“Public transit” means a location, including, but not limited to, a bus stop or train station, where the public may access buses, trains, subways, and other forms of transportation that charge set fares, run on fixed routes, and are available to the public.

“Tandem parking” means that two or more automobiles are parked in any location on a lot and lined up behind one another.

14.14.021 Categories of ADUs

Section 14.14.021 is a summary of the various accessory dwelling unit requirements. If this summary of information conflicts with other sections of this Chapter, those sections shall be binding. See Section 14.14.070 for additional requirements that apply to multi-family ADUs.

Design Standards	Junior ADU	Attached ADU (single-family)	Detached ADU (single-family)
Maximum Size (see 14.14.025 for additional details)	500 sq. ft. created from the existing square footage of the residential structure.	1,200 sq. ft. but no more than 50% of the floor area of an existing or proposed primary dwelling unit (<u>excluding</u> basement area).	1,200 sq. ft. but no more than 50% of the floor area of an existing or proposed primary dwelling unit (<u>including</u> basement area).
Maximum Height	NA	The greater of 16 feet or the height of zoning underlying zoning district	16 feet
Side Setback	NA	4 feet (see exception identified within 14.14.050(f)(5))	4 feet
Rear Setback	NA	4 feet (see exception identified within 14.14.050(f)(5))	4 feet
Kitchen	Cooking appliances can include hot plate, or counter-top cooking. A wall installed oven is not required.	Must include at least a sink, a refrigerator of no less than 10 cubic feet, and either a cooktop and an oven, or a range. A food preparation counter and storage cabinets that are of reasonable size in relation to the size of the ADU are also required.	
Parking Requirement	None	1 uncovered parking space required. See Section 14.14.050(i)(1-6) for the exceptions to this requirement	
Owner Occupancy	Required	Not required	

Short Term Rentals	Prohibited	Prohibited
Impact Fees	None	750 sq. ft. or less-no impact fees 751 sq. ft or more-impact fees are proportionate to principal dwelling.
Utility Fees and Connections	None required.	The accessory dwelling may be served by the primary residence or may have separate utility meters.

14.14.025 Square Footage Chart

For clarity the following chart provides the square footage thresholds for the various forms of accessory dwelling units

Unit Type	Square Footage Limitations
Efficiency Unit	The minimum size of an efficiency unit as defined by the Health and Safety Code shall be 150 square feet.
Junior Accessory Dwelling Unit	The maximum size of a Junior Accessory Dwelling Unit (JADU) shall be 500 square feet created by the conversion of existing square footage of the dwelling unit. However, up to 150 square feet can be added to the existing structure for purposes of ingress and egress to the JADU. The additional square footage shall count towards the 500 square foot maximum.
<u>Attached accessory dwelling unit</u>	The total floor area for an <u>attached</u> accessory dwelling unit shall not exceed one thousand two hundred (1,200) square feet, <u>excluding</u> the basement areas, and shall not be more than fifty (50) percent of the floor area of the existing or proposed principal residence. Notwithstanding this 50% threshold requirement, an ADU of 850 square feet or smaller cannot be denied. More specific requirements are set forth in Section 14.14.050(d).
<u>Detached accessory dwelling unit</u>	The total floor area for a <u>detached</u> accessory dwelling unit shall not exceed one thousand two hundred (1,200) square feet, <u>including</u> basement areas of the detached unit, and shall not be more than fifty (50) percent of the floor area of the existing or proposed principal residence. Notwithstanding this 50% threshold requirement, an ADU of 850 square feet or smaller cannot be denied. More specific requirements are set forth in Section 14.14.050(d).

<p>Maximum size of an accessory dwelling unit that must be approved even if the site is at or above lot coverage and floor area ratio limits</p>	<p>A detached or attached ADU of 850 square feet or smaller cannot be denied for size alone.</p>
<p>Accessory dwelling unit subject to objective design standards</p>	<p>An ADU between 851-1,200 square feet are subject to a zoning clearance review for objective design standards as identified in Chapter 14.06-Chapter 14.16-24.</p>

Section 14.14.030 Location Permitted

A. Accessory dwelling units may be permitted in the following zones: on lots zoned for multifamily or single-family dwellings.

B. Nothing in this chapter shall be construed to authorize construction of new single-family residences in multiple-family districts where such single-family residential use is not otherwise allowed.

14.14.040 General Requirements.

Notwithstanding any local ordinance regulating the issuance of variances or special use permits, or regulations adopted herein to the contrary, an application for a building permit to construct an accessory dwelling unit, or junior accessory dwelling unit, or efficiency unit (“accessory dwelling”) shall be approved or denied ministerial without discretionary review or hearing within sixty (60) days from the date the city receives a completed application if there is an existing single-family or multifamily structure on the lot. The following requirements apply to all accessory dwellings:

- (a) An accessory dwelling shall not be rented for periods less than thirty (30) days. Short term rentals are prohibited.
- (b) Except as allowed by State law, an accessory dwelling shall not be sold or have its title transferred separately from the primary residential structure.
- (c) Deed Restriction. Prior to the issuance of the building permit for the accessory dwelling unit, the owner must record a deed restriction stating that the accessory dwelling unit may not be rented for periods less than thirty (30) days, and that it may not be transferred or sold separate from the primary residential structure.
- (d) The installation of fire sprinklers shall not be required for an accessory dwelling if sprinklers are not required for the primary residence.

- (e) Accessory dwellings are subject to the design standards and other zoning requirements of the zoning district in which the existing single-family dwelling is located and must be built in accordance with the building code set forth in Title 12 of the Los Altos Municipal Code, except for those design, zoning, and building standards inconsistent with state requirements under California Government Code Section 65852.2.
- (f) An accessory dwelling is not subject to residential accessory structure regulations.
- (g) An accessory dwelling will not be subject to any charges and fees other than planning and building permit fees generally applicable to residential construction in the zone in which the property is located, except as otherwise provided herein.
- (h) Any connection fees and capacity charges that may be required must be assessed in compliance with the provisions of State Government Code Section 65852.2 and 65852.22, and as the sections may be amended over time by the State.
- (i) The accessory dwelling must contain water, sewer and gas and/or electric utility connections that are in working condition upon its occupancy. The accessory dwelling may be served by the primary residence or may have separate utility meters. The accessory dwelling will not be considered a new residential use for the purpose of calculating connection fees or capacity charges for these utilities.
- (j) An accessory dwelling unit must have an independent electrical sub-panel, water heating and space heating equipment within the unit or be readily accessible to the occupant on the exterior of the unit.
- (k) Ministerial approval of a permit for creation of an accessory dwelling shall not be conditioned on the correction of pre-existing nonconforming zoning conditions.
- (l) A certificate of occupancy for any accessory dwelling shall not be issued before the local agency issues a certificate of occupancy for the primary dwelling.
- (m) If the applicant requests a delay in processing, the 60-day time period shall be suspended for the period of the delay.
- (n) A kitchen shall be provided for an accessory dwelling unit. A full kitchen requires habitable space used for preparation of food that contains at least a sink, a refrigerator of no less than 10 cubic feet, and either a cooktop and an oven, or a range. A food preparation counter and storage cabinets that are of reasonable size in relation to the size of the ADU are also required.
- (o) Minimum sill height of 5' (60) inches for windows on the second story within 15' of the property line that face out to the neighbors to mitigate privacy concerns shall be required.

14.14.050 Single-Family Residential Accessory Dwelling Unit Standards

Notwithstanding any other provisions of this chapter to the contrary, a single-family residential accessory dwelling unit shall be a permitted as a single-family residential use that shall comply with the following:

(a) Zoning. A single-family residential accessory dwelling unit shall be located on a lot with an existing or proposed primary dwelling in a residential or mixed-use zone district.

(b) Number. Only one (1) detached single-family residential accessory dwelling unit may be permitted on a parcel that contains not more than one existing or proposed single-family residence. Additionally, one Junior Accessory Dwelling Unit JADU maybe allowed within the confines of the existing house.

(c) Relationship to Primary Dwelling. A single-family residential accessory dwelling unit may be within, attached to, or detached from, the proposed or existing primary dwelling, provided that a single-family residential accessory dwelling unit contained within or attached to an existing primary dwelling unit shall have independent exterior access from the existing residence) A detached single-family residential accessory dwelling unit must be located at least five (5) feet from the proposed primary dwelling.

(d) Size.

(1) A studio or one (1) bedroom, attached or detached single-family residential accessory dwelling unit shall be permitted, and limited to eight hundred fifty (850) square feet in floor area, garage areas excluded.

(2) An attached or detached single-family residential accessory dwelling unit with more than one (1) bedroom shall be permitted, and limited to twelve hundred (1,200) square feet in floor area, garage areas excluded. The additional square footage above the 850 square foot allowed by State law shall only shall be allowed if the lot meets the lot coverage and floor area ratio requirements for the applicable zoning district they are located in.

i. The total floor area for an **attached** accessory dwelling unit shall not exceed one thousand two hundred (1,200) square feet, **excluding** the basement areas, and shall not be more than fifty (50) percent of the floor area of the existing or proposed principal residence. Notwithstanding this 50% threshold requirement, an ADU of 850 square feet or smaller cannot be denied.

ii. The total floor area for a **detached** accessory dwelling unit shall not exceed one thousand two hundred (1,200) square feet, **including** basement areas of the detached unit, and shall not be more than fifty (50) percent of the floor area of the existing or proposed principal residence. Not withstand this 50% threshold requirement, an ADU of 850 square feet or smaller cannot be denied.

(e) Height.

(1) The maximum height for a detached single-family residential accessory dwelling unit shall be one-story and sixteen (16) feet.

(2) Attached single-family residential accessory dwelling units shall have a maximum height of equal to the greater of (i) sixteen (16) feet, or (ii) the height limit established for the primary residential structure pursuant to applicable zoning.

(f) Setbacks. A single-family residential accessory dwelling unit is subject to the design criteria and zoning requirements of the district in which the existing single-family dwelling is located and as follows:

(1) A single-family residential accessory dwelling unit must not encroach upon the required front lot line area or side yard-area.

(2) A setback of four (4) feet from the interior side and rear lot lines shall be required for a newly constructed, detached single-family residential accessory dwelling unit that is not constructed in the same location and to the same dimensions as an existing structure. Proposed structures that are four (4) feet or less from the property line shall be required to provide a record survey to the City for proof of setbacks and existing property lines.

(3) The separation from the principal dwelling and any other accessory structure on the lot shall be at least five (5) feet unless implementation of this requirement would prohibit the construction of an 850 square foot detached accessory dwelling unit, in which case this requirement shall be waived provided the ADU complies with California Building Code (CBC) requirements for separation.

(5) No additional zoning setback is required for conversion of an existing permitted accessory structure, living area, or garage space, or conversion of a structure that is constructed in the same location and to the same dimensions as the existing structure.

(g) Detached Accessory Dwelling Unit Daylight Plane

(1) No portion of an attached or detached accessory dwelling unit shall extend above or beyond a daylight plane as follows:

(2) The daylight plane starts at a height of eight feet at the property line and proceeds inward at a 6:12 slope. At ten feet from the property line the structure can increase in height to sixteen (16) feet. All appurtenances, including chimneys, vents and antennas, shall be within the daylight plane. The daylight plane is not applied to a side or rear property line when it abuts a public alley or public street. However, the accessory dwelling unit (ADU) daylight plane shall not be enforced if it prohibits the development of an 850 square foot ADU which is required by state law.

(3) Daylight plane shall not be enforced for an ADU if the structure abuts a city street or alleyway in the rear of the property.

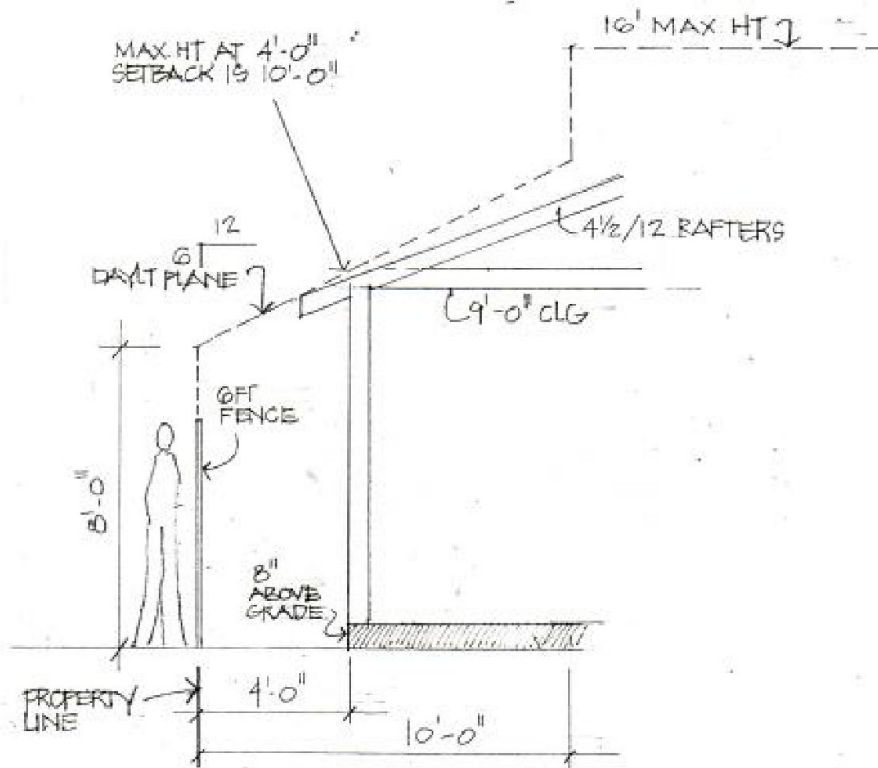

(h) A single-family residential accessory dwelling unit must be built in accordance with the building code set forth in Title 12, except that any design, zoning, and building standards inconsistent with state requirements under California Government Code Section 65852.2 shall not apply.

(i) Parking. One (1) additional uncovered parking space of nine feet by eighteen feet (9X18) shall be required for a newly constructed single-family residential accessory dwelling unit, which may be located within the front setback, in tandem and in an existing driveway including within an interior side yard setback area, unless a specific finding is made that such parking is not feasible due to specific site, topographical or fire and life safety. Notwithstanding the above, a parking stall will not be required for a residential accessory dwelling unit that meets any of the following criteria:

(1) The single-family residential accessory dwelling unit is created as a result of the conversion of existing area of the single-family residence or existing permitted residential accessory structure.

(2) An existing garage, carport or parking structure is converted or demolished to accommodate a single-family residential accessory dwelling unit in the same location. If the required parking for the main single-family residence is removed the property owner must submit a notarized letter to the City acknowledging removal of said parking could create a nonconformity for future expansions of the single-family dwelling.

(3) The single-family residential accessory dwelling unit is within one-half (1/2) mile walking distance of a public transit station, such as a bus stop or train station.

(4) The property is within an architecturally and historically significant historic district.

(5) On-street parking permits are required in the area but not offered to the occupant of the residential accessory dwelling unit.

(6) A vehicle share site is located within one (1) block of the single-family residential accessory dwelling unit.

(j) Design Standards. Architectural review of attached or detached single-family residential accessory dwelling units over 851 square feet or greater will be limited to the following:

(1) Notwithstanding any other provision of this code, a zoning clearance letter shall be issued for accessory dwelling units and shall be reviewed by the director of community development or their designee for compliance with objective design standards as identified within Chapter 14.06(Single Family Zoning Districts or Chapters 14.16-14.24 (Multi Family Zoning Districts). The permit shall be considered ministerial without discretionary review within the time frames required by Section 65852.2 of the Government Code; when the application is in compliance with the relevant standards, the permit shall be issued.

(2) In those instances where an applicant seeks permission to deviate from the standards, a variance shall be filed in accordance with 14.76.070. If the permit application to create an accessory dwelling unit or a junior accessory dwelling unit is submitted with a permit application to create a new single-family dwelling on the lot, the City may delay acting on the permit application for the accessory dwelling unit or the junior accessory dwelling unit until the permitting agency acts on the permit application to create the new single-family dwelling, but the application to create the accessory dwelling unit or junior accessory dwelling unit shall be considered without discretionary review or hearing. If the applicant requests a delay, the 60-day time period shall be suspended for the period of the delay.

(3) The architectural features, window styles, roof slopes, exterior materials, colors, appearance, and design of the single-family residential accessory dwelling unit must be compatible with the existing single-family dwelling.

(4) Minimum sill height of 5' (60) inches for windows on the second story within 15' of the property line that face out to the neighbors to try to mitigate privacy concerns shall be required.

(5) A new single-family residential accessory dwelling unit located within a historic site or neighborhood combining district will be subject to ministerial review for compliance with the design review criteria set forth in section Chapter 12.44 of the Los Altos Municipal Code and must be consistent with the Secretary of Interior's Standards for the Treatment of Historic Properties.

(6) Outside stairways serving a second story single-family residential accessory dwelling unit shall not be constructed on any building elevation facing a public street.

(7) No passageway will be required in conjunction with the construction of any single-family residential accessory dwelling unit.

(k) Streamlined Approval of Accessory Dwelling Units. Notwithstanding the restrictions above, a building permit application for a detached, single-family residential accessory dwelling unit within a residential or mixed-use zone must be a ministerial approved if it is:

(1) Setback four (4) feet from the interior side and rear lot lines.

(2) No larger than eight hundred (850) square feet in floor area; and

(3) No taller than sixteen (16) feet in height.

14.14.060 Junior accessory dwelling unit standards.

Notwithstanding any other provisions in this Article or of this chapter to the contrary, a junior accessory dwelling unit shall be permitted and comply with the following:
(a) Owner-occupancy of the property shall be required for junior accessory dwelling units or the main dwelling unit. The owner may reside in the primary residence, junior accessory dwelling unit or separate residential accessory dwelling unit constructed on the property in compliance with this Article.

(b) One (1) junior accessory dwelling unit may be permitted per residential lot zoned for a single-family residential use, provided that the lot has not more than one (1) existing or proposed single-family residence. A single-family residential lot is allowed to have both 1 junior accessory dwelling unit and one detached accessory dwelling unit.

(c) The unit must be constructed within the existing walls of a single-family dwelling except that an expansion of 150 square feet beyond the existing physical dimensions of the accessory structure may be permitted to accommodate required ingress and egress.

(d) The square footage of the unit shall be at least the minimum size (150 square feet) required for an efficiency unit, up to a maximum size of five hundred (500) square feet in floor area, and must include one bedroom or studio sleeping area.

(e) A separate entrance from the unit to the exterior of the residence, and an interior connection to the main living area may be provided. A second interior doorway for sound attenuation may also be permitted.

(g) At least an efficiency kitchen must be provided in the unit which shall include all of the following:

(1) A cooking facility with appliances. Appliances can include hot plate, or counter top cooking. A property owner does not need to a wall installed oven or stove to qualify for a cooking appliances.

(2) A food preparation counter and storage cabinets that are of reasonable size in relation to the size of the junior accessory dwelling unit.

(h) The unit may include separate bathroom facilities or may share bathroom facilities contained within the primary residence.

(i) No separate utility connection, connection fee or capacity charge, or parking space shall be required for a junior accessory dwelling unit.

(j) a deed restriction shall be required for junior accessory dwelling units and must include the following stipulations:

(1) prohibition on the sale of the JADU separate from the sale of the single family residence

(2) if a JADU is rented, the unit shall not be rented for a period of less than thirty (30) consecutive days

(3) owner occupancy is required for the JADU or the main house, unless the owner is another government agency, land trust or housing organization as allowed by State Law.

14.14.070 Multi-family accessory dwelling unit standards.

Notwithstanding any other provisions of this chapter to the contrary, multi-family accessory dwelling units shall be permitted and comply with the following:

(a) Portions of existing multi-family dwelling structures that are not used as livable space (including, but not limited to, storage rooms, boiler rooms, passageways, attics, basements, or garages), but excluding any residential amenities required to be provided for the facility by the zoning ordinance, or as a condition of project approval, may be converted for use as accessory dwelling units provided that total number of units must not exceed twenty-five (25) percent of the existing multi-family dwelling units or one (1) unit, whichever is greater.

(b) An owner may also construct up to a maximum of two detached accessory dwelling units on a lot that has an existing multifamily dwelling, subject to a height limit of sixteen (16) feet and four (4) foot rear yard and side setbacks.

(c) Accessory dwelling units in multi-family zone districts shall comply with all the objective standards of the zone district they are located in unless inconsistent with the standards provided in this Chapter.

14.14.080 Voluntary Additional Setback

For a detached accessory dwelling unit, the minimum setbacks shall be five feet (5) from the house, and four feet (4) from the side yard and rear yard setbacks. However, so as to reduce the privacy impacts to abutting property owners, applicants are encouraged to voluntarily increases the setbacks to be ten (10) feet from the rear yard and eight feet (8) from the interior side yard.

SECTION 2. CONSTITUTIONALITY. If any section, subsection, sentence, clause or phrase of this code is for any reason held to be invalid or unconstitutional, such decision shall not affect the validity of the remaining portions of this code.

SECTION 3. CEQA. The City Council finds the adoption of this ordinance to be statutorily exempt from the requirements of the California Environmental Quality Act (CEQA) pursuant to Section 21080.17 of the Public Resources Code because it is an ordinance regarding second units in single-family and multifamily residential zones to implement the provisions of Government Code Section 65852.2.

SECTION 4. PUBLICATION. This ordinance shall be published as provided in Government Code section 36933. Within 15 days of the passage of this ordinance, the City Clerk shall cause the full text of the ordinance, with the names of those City Council members voting for and against the ordinance, to be published in an adjudicated newspaper. In lieu of publishing the full text of the ordinance, the City Clerk, if so directed by the City Attorney and within 15 days, shall cause a summary of the ordinance, prepared by the City Attorney and with the names of the City Council members voting for and against the ordinance, to be published in an adjudicated newspaper, and shall post in the office of the City Clerk a certified copy of the full text of the ordinance, along with the names of those City Council members voting for and against the ordinance. The publication of a summary of the ordinance in lieu of the full text of the ordinance is authorized only where the requirements of Government Code Section 36933(c)(1) are met.

SECTION 5. EFFECTIVE DATE. This ordinance shall be effective upon the commencement of the thirty-first day following the adoption date.

SECTION 6. TRANSMISSION TO HCD. The City Clerk shall send a certified copy of this ordinance to the Department of Housing and Community Development (HCD) within sixty (60) days after adoption, as required by state law.

The foregoing ordinance was duly and properly introduced at a regular meeting of the City Council of the City of Los Altos held on _____, 2020 and was thereafter, at a regular meeting held on _____, 2020 passed and adopted by the following vote:

- AYES:
- NOES:
- ABSENT:
- ABSTAIN:

Janis C. Pepper, MAYOR

Attest:

Jon Maginot, CMC, CITY CLERK

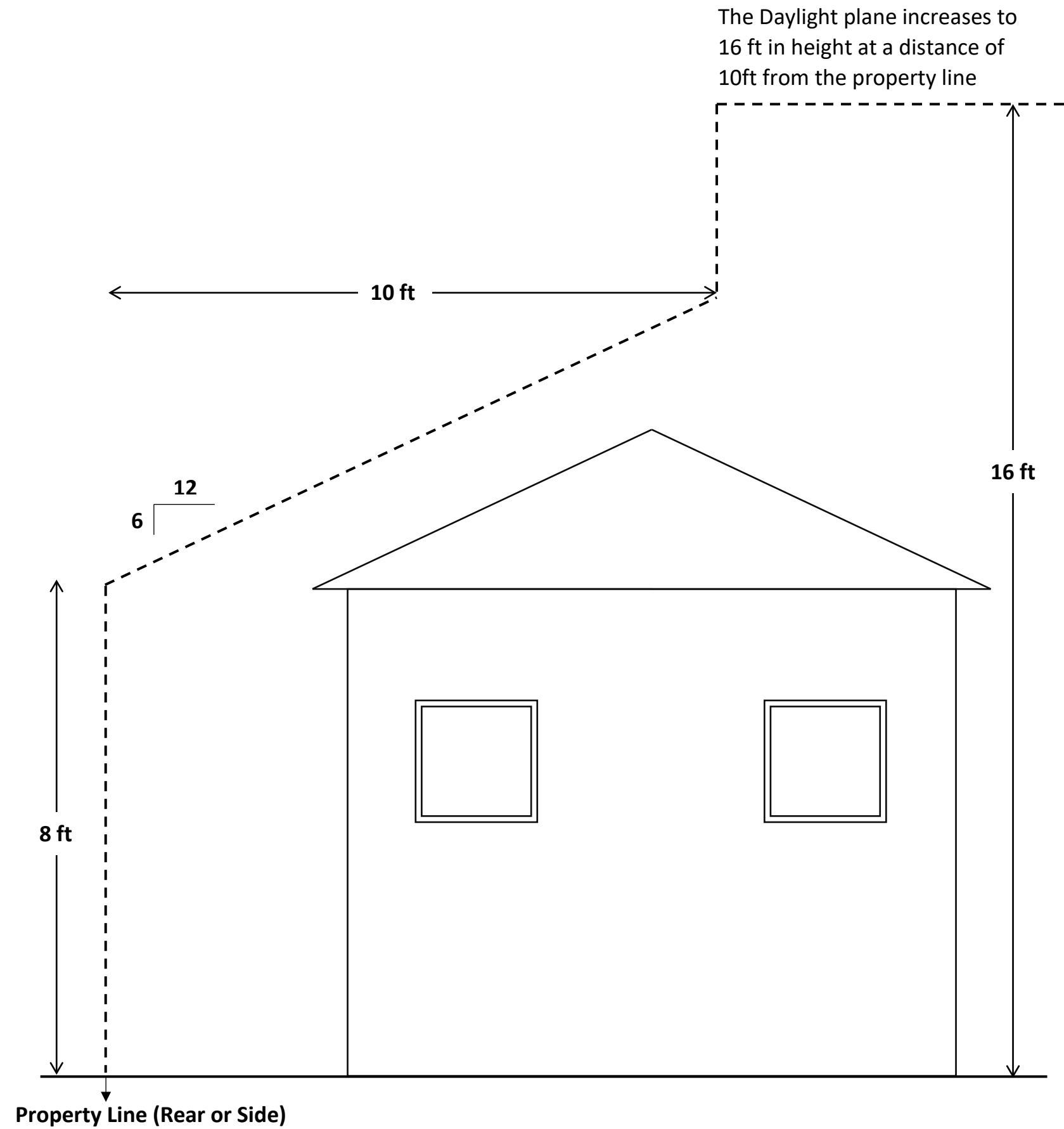

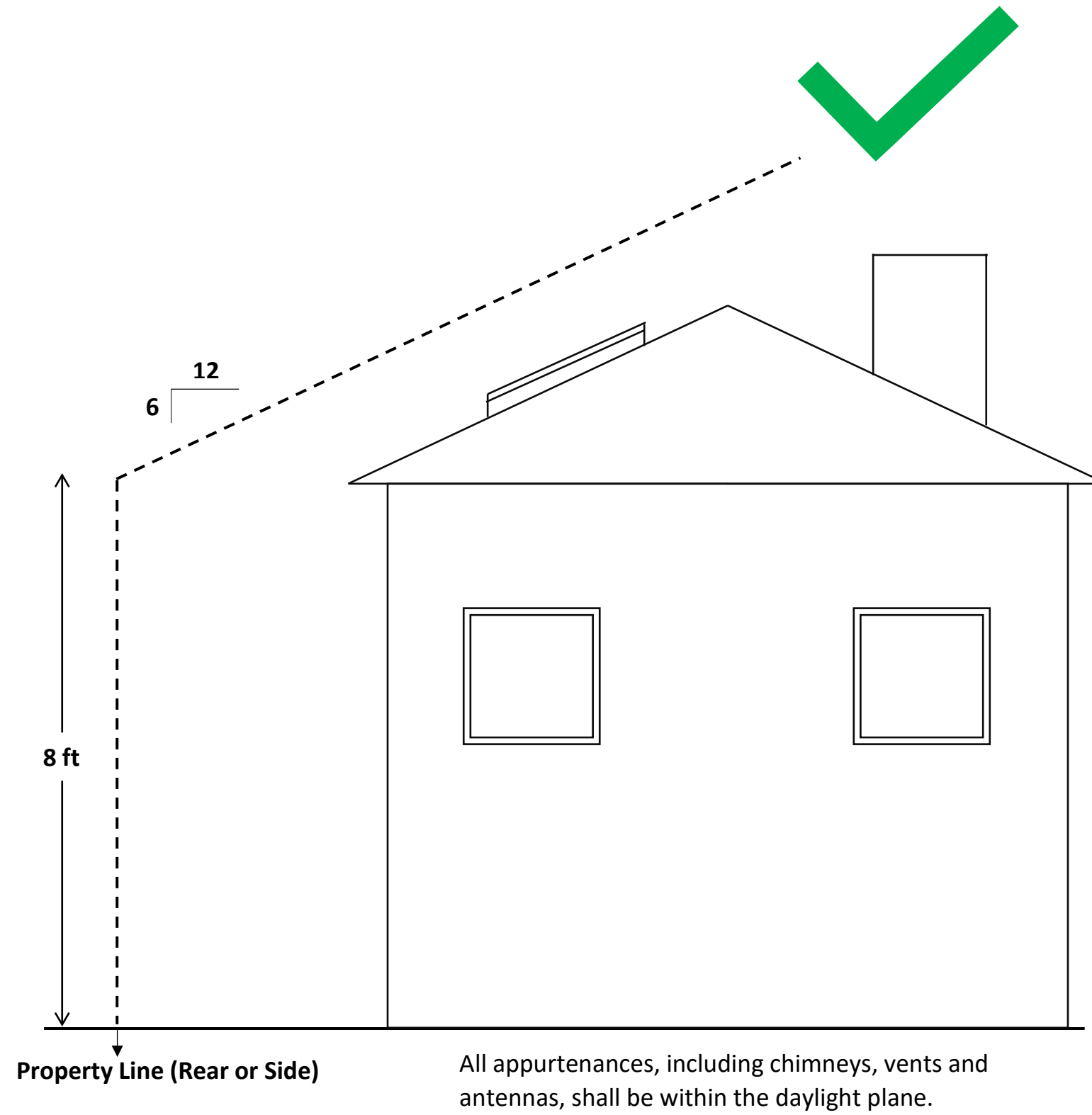

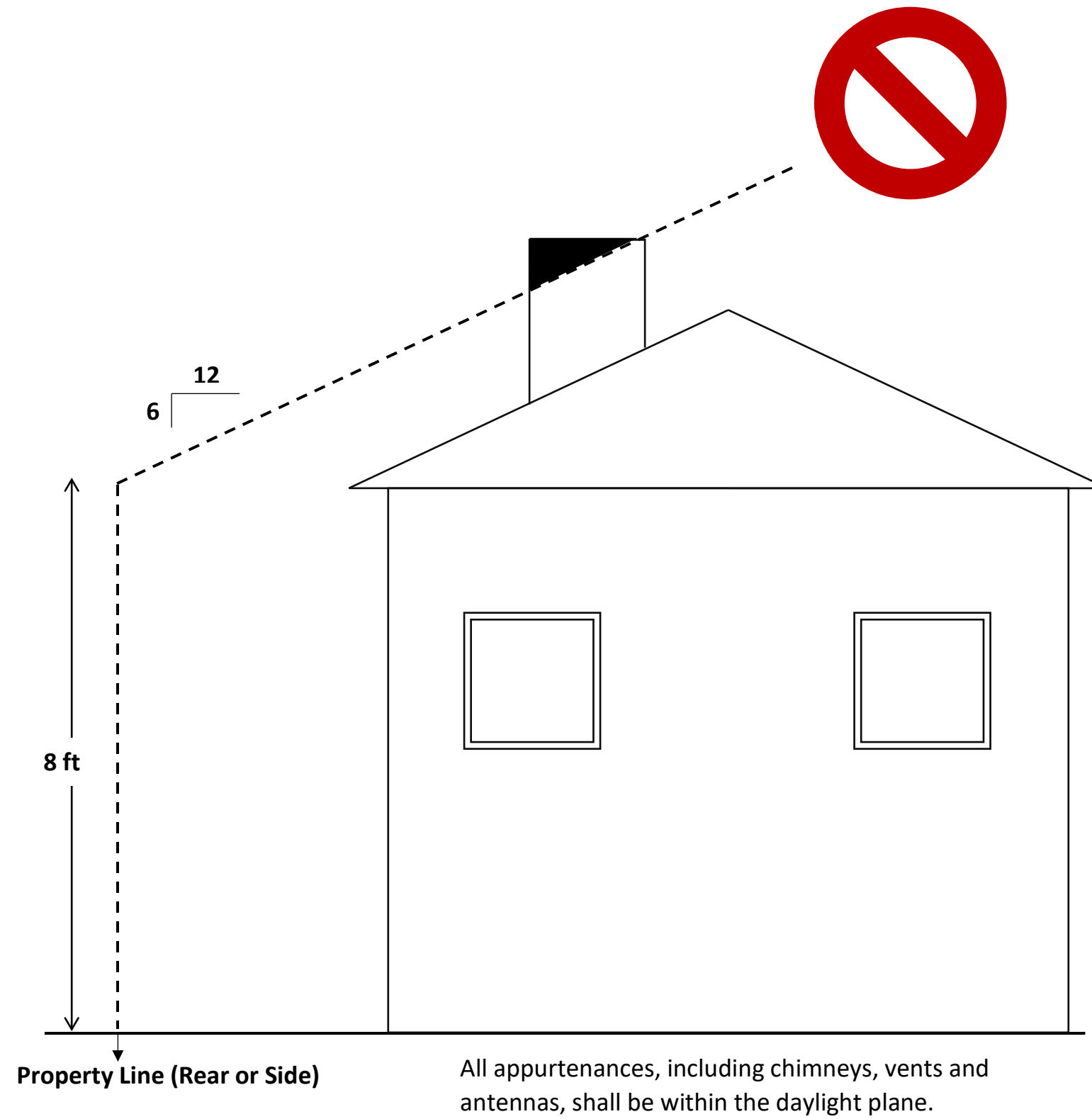



ITEMS FOR DISCUSSION/ ACTION Agenda Item # 2

AGENDA REPORT SUMMARY

Meeting Date: May 7, 2020

Subject: Repeal and Replace Chapter 14.14 of the Los Altos Municipal Code (Accessory and Junior Dwelling Units) by adopting Zoning Text Amendment 20-0001

Prepared by: Guido F. Persicone, Planning Services Manager, AICP

Reviewed by: Jon Biggs, Community Development Director

Attachment(s):

- A. Draft ADU Ordinance
- B. Voluntary Daylight Plane Provisions

Initiated by:

City staff

Previous Council Consideration:

2018

Fiscal Impact:

No direct fiscal impact is anticipated

Environmental Review:

Adoption of an accessory dwelling unit ordinance is subject to a statutory exemption from environmental review (Public Resource Code Section 15282(h)). In addition, the action being considered does not constitute a “project” within the meaning of the California Environmental Quality Act (“CEQA”) pursuant to CEQA Guidelines Section 15061(b)(3) as the activity is covered by the general rule that CEQA applies only to projects which have the potential for causing a significant effect on the environment. Where it can be seen with certainty that there is no possibility that the activity in question may have a significant effect on the environment, the activity is not subject to CEQA. Projects that are subject to the ADU regulations will be evaluated pursuant to CEQA on an individual basis. However, ADUs are generally exempt from CEQA review under CEQA Guidelines Section 15301 (Existing Facilities) and/or Section 15303 (New Construction or Conversion of Small Structures).

Policy Question(s) for Council Consideration:

- Do the proposed code amendments ensure the Los Altos Municipal Code is consistent with recent changes to state law?



Subject: Proposed Amendments to the Chapter 14.14 (Accessory Dwelling Unit) Ordinance
Second Planning Commission Meeting

Summary:

- The ordinance repeals and replaces Chapter 14.14, Accessory Dwelling Units, to ensure consistency with State law.

Staff Recommendation:

Staff suggests that the Planning Commission recommend adoption of the proposed ordinance to the City Council.

Purpose

The purpose of the proposed amendments is to ensure compliance with new state laws affecting the development of accessory dwelling unit and junior accessory dwelling units in the residential zone districts of the City.

Background

On April 16, 2020 the Planning Commission reviewed the draft accessory dwelling unit ordinance (ADU). At the conclusion of the meeting, the Commission requested that the ordinance be revised and be reviewed by the legislative body at the May 7, 2020 meeting.

In addition to the Commission's edits, on the day of the hearing the State Housing and Community Development Department (State HCD) reached out to City staff to provide some direction on edits that would be necessary to receive State support for the draft ordinance. This was extremely helpful as State approval within sixty (60) days of adoption is a legal requirement from the most recent legislation. In order for the Commission and members of the public to easily follow the revisions, the edits will be documented within this report and provided section by section

Section 14.14.020 Definitions

State HCD wanted it to be clear that the JADU is not for multi-family buildings.

“Junior accessory dwelling unit” means a unit that is no more than 500 square feet in size, includes an efficiency kitchen consistent with building code standards, is contained entirely within the walls of a single-family residence or ~~multi-family building~~, and may include separate sanitation facilities or may share sanitation facilities with the existing structure or unit.

The Planning Commission requested that verbiage be added to the definitions for “living area” and “passageway”.



Subject: Proposed Amendments to the Chapter 14.14 (Accessory Dwelling Unit) Ordinance
Second Planning Commission Meeting

Living area, including basements and attics means interior habitable area as defined by the California Building Code, was added to the definitions section.

Passageway-the definition of passageway was added to the definitions.

14.14.025 (New Section)

The Planning Commission requested that a chart be added to the ordinance, so property owners were given clear direction regarding the square footage calculations from the draft ordinance. This chart has been added to section 14.14.025 of the draft ordinance.

Square Footage	Implications
500 sq. ft.	500 sq. ft. is the maximum size of a Junior Accessory Dwelling Unit (JADU).
750 sq. ft.	No impact fees shall be charged on an accessory dwelling unit that is 750 square feet or less. If an accessory dwelling unit is 751 or more impact fees can be charged but it must be proportionate to the size of the main house.
800 sq. ft.	The total floor area for a detached accessory dwelling unit shall not exceed one thousand two hundred (1,200) square feet, including basement areas, and shall not be more than fifty (50) percent of the floor area of the existing or proposed principal residence. Notwithstanding this requirement the ADU has to be at least 800 square feet.
850 sq. ft.	A minimum size for a detached accessory dwelling unit shall be 850 square feet
1,200 sq. ft.	The total floor area for an attached or detached accessory dwelling unit shall not exceed one thousand two hundred (1,200) square feet, including basement areas, and shall not be more than fifty (50) percent of the floor area of the existing or proposed principal residence.

Section 14.14.030(a)

This section was modified by State HCD to make it clear that ADUs are allowed in in all zoning districts for multi-family or single-family dwellings.



Subject: Proposed Amendments to the Chapter 14.14 (Accessory Dwelling Unit) Ordinance
Second Planning Commission Meeting

(a) accessory dwelling units may be permitted in the following zones: on lots zoned for multi-family or single-family dwelling.

Section 14.14.040(b)

State HCD requested that the words “Junior Accessory Dwelling Unit” were removed from 14.14.040(b) to make it clear that JADUs cannot be sold separately.

(b) Except ~~Junior~~ accessory dwelling unit as allowed by State law, an accessory dwelling shall not be sold or have its title transferred separately from the primary residential structure.

Section 14.14.040(i)

The word served was added to 14.14.040 General Requirements

The accessory dwelling must contain water, sewer and gas and/or electric utility connections that are in working condition upon its occupancy. The accessory dwelling may be served by the primary residence or may have separate utility meters. The accessory dwelling will not be considered a new residential use for the purpose of calculating connection fees or capacity charges for these utilities.

Section 14.14.040(m)

The word “tolled” was replaced with the word “suspended” in 14.14.040(m)

(m) If the applicant requests a delay in processing, the 60-day time period shall be suspended for the period of the delay.

Section 14.14.040(n)-

During the preparation for the second Commission meeting, City staff discussed the draft ordinance with the City of San Jose staff, who have added the following language to their ordinance:

14.14.040 (i) General Requirements. Minimum sill height of 5’ (60) inches for windows on the second story within 15’ of the property line that face out to the neighbors to try to mitigate privacy concerns shall be required.

Since the new ordinance allows structures to be 16 feet tall, someone could potentially build a loft that has a second story window. Adding this language will help reduce privacy impacts to abutting property owners. The Commission can choose to accept this friendly staff amendment or remove it



Subject: Proposed Amendments to the Chapter 14.14 (Accessory Dwelling Unit) Ordinance
Second Planning Commission Meeting

from the recommendation to the City Council.

14.14.050(b)

State HCD wanted the ordinance to be clear that 1 JADU is allowed within the confines of the house.

- (b) Number. Only one (1) detached single-family residential accessory dwelling unit may be permitted on a parcel that contains not more than one existing or proposed single-family residence. Additionally, one Junior Accessory Dwelling Unit JADU maybe allowed within the confines of the existing house.

14.14.050(d)(1)

State HCD wanted it to be clear that 850 was the minimum size of an attached or detached ADU.

- (1) A studio or one (1) bedroom, attached or detached single-family residential accessory dwelling unit shall be permitted, and limited to eight hundred fifty (850) square feet in floor area, garage areas excluded.

14.14.050(d)(2)(i-ii)

State HCD wanted it to be clear that the 50% rule within the ordinance was valid, but a property owner could still get an 800 square foot ADU:

- (1-2) i-ii. The total floor area for an attached accessory dwelling unit shall not exceed one thousand two hundred (1,200) square feet, excluding the basement areas, and shall not be more than fifty (50) percent of the floor area of the existing or proposed principal residence. Notwithstanding this requirement, the ADU can be up to 800 square feet.

14.14.050(d)(3)

State HCD removed this section stating it was not compliant with State law:

- ~~(3) Notwithstanding the size restrictions provided above, the total floor area of an attached single-family residential accessory dwelling unit, including internal conversions of existing primary living space, shall not exceed fifty (50) percent of the existing or proposed primary dwelling gross floor area, not including the garage. For internal conversions, the accessory dwelling unit floor area shall not exceed fifty (50) percent of the primary residential living space, after conversion.~~



Subject: Proposed Amendments to the Chapter 14.14 (Accessory Dwelling Unit) Ordinance
Second Planning Commission Meeting

14.14.050(e)(2) (Height)

This section needs to be removed because it was a typographical error by staff during the preparation of the ordinance.

~~(2) The maximum height of a single family residential accessory dwelling unit that is proposed to be constructed above a detached garage shall be twenty-four (24) feet.~~

14.14.050(f)(3)

State HCD requested the twelve-foot setback be removed as this was not compliant with state law.

~~(3) The side yard setback shall be no less than 12 feet for an attached or detached accessory dwelling unit that is abutting a city street or alleyway.~~

14.14.050(g)(1-2) Daylight Plane Provisions

By far the most discussion at the April Planning Commission meeting was around the daylight plane provisions. After a lengthy discussion, the Planning Commission requested that the daylight plane provisions be modified to start at a height of eight (8) feet with a 6/12 roof pitch.

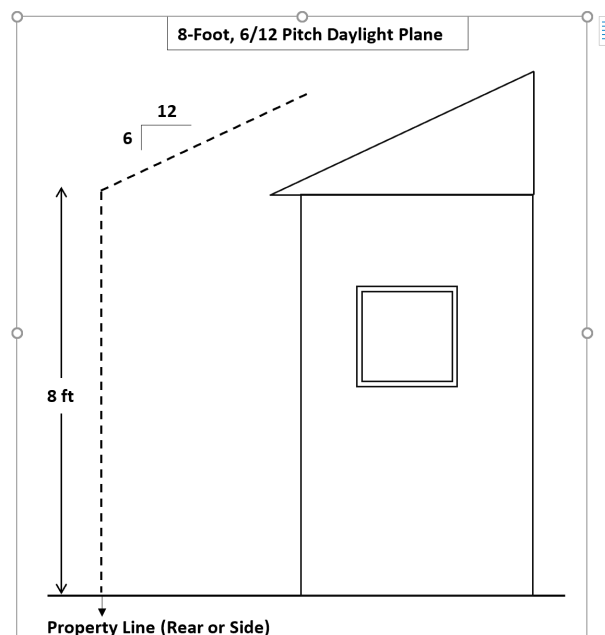



Subject: Proposed Amendments to the Chapter 14.14 (Accessory Dwelling Unit) Ordinance
Second Planning Commission Meeting

14.14.050(i)

The Planning Commission requested that the parking space for a new detached ADU be an uncovered standard parking space of 9X18

- (i) Parking. One (1) additional uncovered parking space of nine feet by eighteen feet (9X18) shall be required for a newly constructed single-family residential accessory dwelling unit, which may be located within the front setback, in tandem and in an existing driveway including within an interior side yard setback area, unless a specific finding is made that such parking is not feasible due to specific site, topographical or fire and life safety. Notwithstanding the above, a parking stall will not be required for a residential accessory dwelling unit that meets any of the following criteria:

14.14.050(i)(2)

The new ADU legislation states that conversion of a garage does not require replacement parking for the ADU. However, this could create a nonconforming situation for future additions to the house. The Planning Commission is requesting that before proceeding that the property owner submit a notarized letter to the City stating they understand the creation of this nonconforming situation. The word 'notarized' was added to the ordinance:

- (2) An existing garage, carport or parking structure is converted or demolished to accommodate a single-family residential accessory dwelling unit in the same location. If the required parking for the main single-family residence is removed the property owner must submit a notarized letter to the City acknowledging removal of said parking could create a nonconformity for future expansions of the single-family dwelling.

14.14.050(j) Zoning Clearance Letter

State law allows for streamlined review of accessory dwelling units that are 850 square feet or less as this is allowed by right by the new legislation. However, the Commission inquired about what the design review process would be for ADUs greater than 850. The intent of the ADU legislation dating back to 2014 is to continue to streamline the development review process and to limit the discretion of planning departments to deny said permits. The section of the ordinance was sent to State HCD, they requested that the last sentence, underlined below make it clear that the ADU is not a discretionary review. Below is sample language for these type of projects:



Subject: Proposed Amendments to the Chapter 14.14 (Accessory Dwelling Unit) Ordinance
Second Planning Commission Meeting

(1) Notwithstanding any other provision of this code, a zoning clearance letter shall be issued for accessory dwelling units shall be reviewed by the director of community development or his/her designee for compliance with objective design standards as identified within Chapter 14.06(Single Family Zoning Districts or Chapters 14.16-14.24 (Multi Family Zoning Districts). The permit shall be considered ministerial without discretionary review within the time frames required by Section 65852.2 of the Government Code; when the application is in compliance with the relevant standards, the permit shall be issued. In those instances where an applicant seeks permission to deviate from the standards, a variance shall be filed in accordance with 14.76.070. If the permit application to create an accessory dwelling unit or a junior accessory dwelling unit is submitted with a permit application to create a new single-family dwelling on the lot, the City may delay acting on the permit application for the accessory dwelling unit or the junior accessory dwelling unit until the permitting agency acts on the permit application to create the new single-family dwelling, but the application to create the accessory dwelling unit or junior accessory dwelling unit shall be considered without discretionary review or hearing. If the applicant requests a delay, the 60-day time period shall be tolled for the period of the delay

As written the Planning Division would still review the project for objective zoning standards but a design review permit would not be required, thus limiting the discretion of City which is in conformance with the intent of recent legislation.

14.14.050 (k)(1)

As stated earlier State HCD requested that the City remove the requirement for having a twelve (12) foot setback for corner lots.

14.14.060 Junior accessory dwelling unit standards.

Junior Accessory Dwelling Unit-The state law is clear that an expansion of 150 square feet can be done for ingress/egress purposes for a JADU. Some cities are strictly following this while others are allowing remodels/additions to a house to include a JADU. Los Altos City staff would like direction from the Planning Commission as to what recommendation should be made to the City Council regarding this item.

14.14.060(a)

The Commission wanted it to be clear that the JADU or the property has to be in conformance with state law which mandates owner occupancy either in the main house or the JADU.

- (a) Owner-occupancy of the property shall be required for junior accessory dwelling units or the main dwelling unit. The owner may reside in the primary residence, junior accessory



Subject: Proposed Amendments to the Chapter 14.14 (Accessory Dwelling Unit) Ordinance
Second Planning Commission Meeting

dwelling unit or separate residential accessory dwelling unit constructed on the property in compliance with this Article

14.14.060I

State HCD wanted it to be clear that a JADU has to be within a house not an accessory structure.

I The unit must be constructed within the existing walls of a single-family dwelling ~~or accessory structure~~, except that an expansion of 150 square feet beyond the existing physical dimensions of the accessory structure may be permitted to accommodate required ingress and egress.

14.14.060(i)

State HCD made the edit that the JADU may have an interior connection to the main house.

(i) A separate entrance from the unit to the exterior of the residence, and an interior connection to the main living area ~~shall~~ may be provided. A second interior doorway for sound attenuation may also be permitted.

14.14.060(g)(1)

State HCD made the edit stating that even a hot place or counter top cooking appliance would meet the requirements of state law that a JADU has to have a cooking facility.

(1) A cooking facility with appliances. Appliances can include hot plate, or counter-top cooking. A property owner does not have to a wall installed oven or stove to qualify for a cooking appliance.

Additional Information/Discussion Items

Approved Accessory Dwelling Units-Commissioner Phoebe Bressack asked how many ADUs were approved. In 2019 the Planning Division approved twenty-four (24) ADUs.

Additional Concessions/Incentives

The Commission requested City staff identify more relaxed daylight plane provisions for property owners who voluntarily increased the setbacks of the ADUs. Please see Attachment B (Voluntary Daylight Plane Provisions) for additional details.



Subject: Proposed Amendments to the Chapter 14.14 (Accessory Dwelling Unit) Ordinance
Second Planning Commission Meeting

Additionally, after additional research the City Attorney has determined reduction of fees could be warranted, but only if it was universally applied. The City Council can:

- Set the ADU permit fees at zero. This would not trigger prevailing wage.
- Reduce the ADU permit fees in the fee schedule so that it is not an ad hoc waiver or reduction. This would not trigger prevailing wage.
- There is a prevailing wage exemption for private residential projects on private property that are not built according to an agreement with a state agency, redevelopment agency or local public housing authority.

Discussion/Analysis

Due to the wide breadth of changes required by state law, including provisions of Junior ADUs(JADUs) and the fact that the current ordinance does not actually provide setback or daylight plane provisions for ADUs but rather relies on the Accessory Structure Ordinance, City staff are recommending that the entire ordinance be repealed and replaced.

Los Altos General Plan Conformance

General Plan Land Use Goal 2: Review and amend (as needed) the Zoning Ordinance to provide consistency with new state legislation and court decisions. Consider Zoning Ordinance amendments that implement the use and development of goals, policies and plan objectives for the identified planning areas (Downtown, El Camino Real Corridor, and Foothill Plaza).

Housing Element Policy 4.2: The City will encourage the development of affordable second dwelling units that conform to zoning regulations.

Program 4.2.1 – Facilitate new construction of second dwelling units.

Program 4.2.2-Study the feasibility of reducing minimum lot sizes for second living units.

Options

- 1) Recommend approval of Zoning Text Amendment 20-0001 to the City Council.

Advantages: Ensure compliance with new state laws.

Disadvantages: Results in less control over accessory dwelling units in Los Altos.

- 2) Recommend denial of the draft ordinance to the City Council



Subject: Proposed Amendments to the Chapter 14.14 (Accessory Dwelling Unit) Ordinance
Second Planning Commission Meeting

Advantages: There is no advantage to denying this ordinance as noncompliance with State law is not a viable position for a municipal agency to be in.

Recommendation

The staff recommends Option 1.

ORDINANCE NO. 2020-___

AN ORDINANCE OF THE CITY COUNCIL OF THE CITY OF LOS ALTOS
REPEALING AND REPLACING THE ACCESSORY DWELLING UNIT
ORDINANCE AND MAKING FINDINGS OF CEQA EXEMPTION

GREEN EDITS-FROM THE COMMISSION
YELLOW EDITS-FROM STATE HCD
BLUE EDITS-EDITS FROM STAFF

WHEREAS, the State Legislature has found that accessory dwelling units are a necessary and valuable form of housing in California; and

WHEREAS, accessory dwelling units help diversify the City's housing stock and help provide rental units that are affordable; and

WHEREAS, accessory dwelling units offer lower cost housing to meet the needs of existing and future residents within existing neighborhoods, while respecting neighborhood character; and

WHEREAS, accessory dwelling units provide housing for family members, students, the elderly, in-home health care providers, the disabled, and others within existing neighborhoods; and

WHEREAS, it is the intent of this ordinance to allow and promote the development of accessory dwelling units; and

WHEREAS, this Ordinance implements Program 4.2.1 and Program 4.2.2 of the City's 2015-2023 Housing Element by facilitating the development of new accessory dwelling units; and

WHEREAS, this Ordinance is exempt from environmental review pursuant to Section 15061 and Section 15301 of the California Environmental Quality Act Guidelines, as amended.

NOW THEREFORE, the City Council of the City of Los Altos does hereby ordain as follows:

SECTION 1. AMENDMENT OF CODE: Chapter 14.14 of Title 14 of the Los Altos Municipal Code is hereby repealed in its entirety and replaced with the new standards and shall read as follows:

Section 14.14.010 Purpose and Intent.

The intent of this chapter is to provide for accessory dwelling units and junior accessory dwelling units, collectively known as an accessory dwelling, on lots zoned to allow single-family or multifamily dwelling residential use that include a proposed or existing dwelling. Accessory dwelling units contribute needed housing to the City of Los Altos housing stock

and enhance housing opportunities. An accessory dwelling unit is considered a residential use that is consistent with the existing general plan and zoning designations for the lot. The accessory dwelling unit is not included in calculation of residential density for the purposes of determining general plan conformance.

14.14.020 Definitions.

As used in this section, the following terms mean:

“Accessory dwelling unit” means an attached or a detached residential dwelling unit that provides complete independent living facilities ~~one or more persons~~ and is located on a lot with a proposed or existing primary residence. It shall include permanent provisions for living, sleeping, eating, cooking, and sanitation on the same parcel as the single-family or multi-family dwelling is or will be situated. An accessory dwelling unit also includes the following:

(A) An efficiency unit, as defined in Section 17958.1 of the Health and Safety Code.

(B) A manufactured home, as defined in Section 18007 of the Health and Safety Code.

“Attached accessory dwelling unit” means a residential dwelling unit that is created as a result of internal conversion, addition, or combination thereof made to the primary residential dwelling unit.

“Multi-family housing” means a dwelling unit or group of dwelling units on one site that contains separate living units for two or more families that may have joined services or facilities or both.

“Junior accessory dwelling unit” means a unit that is no more than 500 square feet in size, includes an efficiency kitchen consistent with building code standards, is contained entirely within the walls of a single-family residence ~~multi-family building~~, and may include separate sanitation facilities or may share sanitation facilities with the existing structure or unit.

“Living area” means the interior habitable area of a dwelling unit, including basements and attics, ~~if defined as habitable by the California Building Code (CBC)~~ but does not include a garage or any accessory structure.

“Nonconforming zoning condition” means a physical improvement on a property that does not conform with current zoning standards.

~~“Passageway”~~ The term passageway has the meaning defined by Government Code Section 65852.2, which states: A pathway that is unobstructed clear to the sky and extends from a street to one entrance of the accessory dwelling unit.

“Public transit” means a location, including, but not limited to, a bus stop or train station, where the public may access buses, trains, subways, and other forms of transportation that charge set fares, run on fixed routes, and are available to the public.

“Tandem parking” means that two or more automobiles are parked in any location on a lot and lined up behind one another.

14.14.025 Square Footage Chart

For clarity the following chart provides the square footage thresholds for the various forms of accessory dwelling units

Square Footage	Limitations
500 sq. ft.	500 sq. ft. is the maximum size of a Junior Accessory Dwelling Unit (JADU).
750 sq. ft.	No impact fees shall be charged on an accessory dwelling unit that is 750 square feet or less. If an accessory dwelling unit is 751 or more impact fees can be charged but it must be proportionate to the size of the main house.
800 sq. ft.	The total floor area for a detached (should this be for an attached unit?) accessory dwelling unit shall not exceed one thousand two hundred (1,200) square feet, including basement areas, and shall not be more than fifty (50) percent of the floor area of the existing or proposed principal residence. Notwithstanding this , the ADU has to be at least 800 square feet.
850 sq. ft.	A minimum size for a detached accessory dwelling unit shall be 850 square feet
1,200 sq. ft.	The total floor area for an attached or detached accessory dwelling unit shall not exceed one thousand two hundred (1,200) square feet, including basement areas, and shall not be more than fifty (50) percent of the floor area of the existing or proposed principal residence.

Section 14.14.030 Location Permitted

A. Accessory dwelling units may be permitted in the following zones: on lots zoned for multi family or single family dwellings.

B. Nothing in this chapter shall be construed to authorize construction of new single-family residences in multiple-family districts where such single-family residential use is not otherwise allowed.

14.14.040 General Requirements.

Notwithstanding any local ordinance regulating the issuance of variances or special use permits, or regulations adopted herein to the contrary, an application for a building permit to construct an accessory dwelling unit, or junior accessory dwelling unit, or efficiency unit (“accessory dwelling”) shall be approved or denied ministerial without discretionary review or hearing within sixty (60) days from the date the city receives a completed application if there

is an existing single-family or multifamily structure on the lot. The following requirements apply to all accessory dwellings:

- (a) An accessory dwelling shall not be rented for periods less than thirty (30) days. Short term rentals are prohibited.
- (b) Except **Junior Accessory dwelling unit** as allowed by State law, an accessory dwelling shall not be sold or have its title transferred separately from the primary residential **structure**.
- (c) Deed Restriction. Prior to the issuance of the building permit for the accessory dwelling unit, the owner must record a deed restriction stating that the accessory dwelling unit may not be rented for periods less than thirty (30) days, that it may not be transferred or sold separate from the primary residential structure,
- (d) The installation of fire sprinklers shall not be required for an accessory dwelling if sprinklers are not required for the primary residence.
- (e) Accessory dwellings are subject to the design standards and other zoning requirements of the zoning district in which the existing single-family dwelling is located and must be built in accordance with the building code set forth in Chapter 6 of the Los Altos Municipal Code, except for those design, zoning, and building standards inconsistent with state requirements under California Government Code Section 65852.2.
- (f) An accessory dwelling is not subject to residential accessory structure regulations.
- (g) An accessory dwelling will not be subject to any charges and fees other than building permit fees generally applicable to residential construction in the zone in which the property is located, except as otherwise provided herein.
- (h) Any connection fees and capacity charges that may be required must be assessed in compliance with the provisions of State Government Code Section 65852.2 and 65852.22, and as the sections may be amended over time by the State.
- (i) The accessory dwelling must contain water, sewer and gas and/or electric utility connections that are in working condition upon its occupancy. The accessory dwelling may be **served** by the primary residence or may have separate utility meters. The accessory dwelling will not be considered a new residential use for the purpose of calculating connection fees or capacity charges for these utilities.
- (j) An accessory dwelling unit must have an independent electrical sub-panel, water heating and space heating equipment within the unit or be readily accessible to the occupant on the exterior of the unit.
- (k) Ministerial approval of a permit for creation of an accessory dwelling shall not be conditioned on the correction of pre-existing nonconforming zoning conditions.
- (l) A certificate of occupancy for any accessory dwelling shall not be issued before the local agency issues a certificate of occupancy for the primary dwelling.

(m) If the applicant requests a delay in processing, the 60-day time period shall be **suspended** for the period of the delay.

(n) **Minimum sill height of 5' (60) inches for windows on the second story within 15' of the property line that face out to the neighbors to try to mitigate privacy concerns shall be required.**

14.14.050 Single-Family Residential Accessory Dwelling Unit Standards

Notwithstanding any other provisions of this chapter to the contrary, a single-family residential accessory dwelling unit shall be a permitted as a single-family residential use that shall comply with the following:

(a) Zoning. A single-family residential accessory dwelling unit shall be located in a residential or mixed-use zone district that permits single-family residential development of the lot.

(b) Number. Only one (1) detached single-family residential accessory dwelling unit may be permitted on a parcel that contains not more than one existing or proposed single-family residence. **Additionally, one Junior Accessory Dwelling Unit JADU maybe allowed within the confines of the existing house.**

(c) Relationship to Primary Dwelling. A single-family residential accessory dwelling unit may be within, attached to, or detached from, the proposed or existing primary dwelling, provided that:

(1) A single-family residential accessory dwelling unit contained within or attached to an existing primary dwelling unit shall have independent exterior access from the existing residence; and

(2) A detached single-family residential accessory dwelling unit must be located at least five (5) feet from the proposed primary dwelling.

(d) Size.

(1) A studio or one (1) bedroom, attached or detached single-family residential accessory dwelling unit shall be permitted, and limited to eight hundred fifty (850) square feet in floor area, garage areas excluded.

(2) An attached or detached single-family residential accessory dwelling unit with more than one bedroom shall be permitted, and limited to twelve hundred (1,200) square feet in floor area, garage areas excluded. **The additional square footage above the 850 square foot allowed by State law shall only be allowed if the lot meets the lot coverage and floor area ratio requirements for the zone district they are located in.**

i. The total floor area for an attached accessory dwelling unit shall not exceed one thousand two hundred (1,200) square feet, excluding the basement areas, and shall not be more than fifty (50) percent of the floor area of the existing or proposed principal residence. **Notwithstanding this requirement, the ADU can be up to 800 square feet.**

ii. The total floor area for a detached accessory dwelling unit shall not exceed one thousand two hundred (1,200) square feet, including basement areas, and shall not be more than fifty (50) percent of the floor area of the existing or proposed principal residence. Notwithstanding this requirement, the ADU can be up to 800 square feet.

~~(3) Notwithstanding the size restrictions provided above, the total floor area of an attached single-family residential accessory dwelling unit, including internal conversions of existing primary living space, shall not exceed fifty (50) percent of the existing or proposed primary dwelling gross floor area, not including the garage. For internal conversions, the accessory dwelling unit floor area shall not exceed fifty (50) percent of the primary residential living space, after conversion.~~

(e) Height.

(1) The maximum height for a detached single-family residential accessory dwelling unit shall be one-story and sixteen (16) feet.

~~(2) The maximum height of a single-family residential accessory dwelling unit that is proposed to be constructed above a detached garage shall be twenty-four (24) feet.~~

(3) Attached single-family residential accessory dwelling units shall comply with the height limits established for the primary residential structure.

(f) Setbacks. A single-family residential accessory dwelling unit is subject to the design criteria and zoning requirements of the district in which the existing single-family dwelling is located and as follows:

(1) A single-family residential accessory dwelling unit must not encroach upon the required front or street side yard area.

(2) A setback of four (4) feet from the interior side and rear lot lines shall be required for a newly constructed, detached single-family residential accessory dwelling unit that is not constructed in the same location and to the same dimensions as an existing structure. Proposed structures that are four (4) feet or less from the property line shall be required to provide a record survey to the City for proof of setbacks and existing property lines.

~~(3) The side yard setback shall be no less than 12 feet for an attached or detached accessory dwelling unit that is abutting a city street or alleyway.~~

(4) The separation from the main house and any other accessory structure on the lot shall be at least five (5) feet unless implementation of this requirement would prohibit the construction of an 850 square foot detached accessory dwelling unit, in which case this requirement shall be waived to be no less than three feet (3). If it is 3 feet the ADU must comply with California Building Code (CBC) requirements for separation.

(5) No additional zoning setback is required for conversion of an existing permitted accessory structure, living area, or garage space, or conversion of a structure that is constructed in the same location and to the same dimensions as the existing structure.

(g) Detached Accessory Dwelling Unit Daylight Plane

(1) No portion of an attached or detached accessory dwelling unit shall extend above or beyond a daylight plane as follows:

(2) The daylight plane starts at a height of eight feet at the property line and proceeds inward at a 6:12 slope. All appurtenances, including chimneys, vents and antennas, shall be within the daylight plane. The daylight plane is not applied to a side or rear property line when it abuts a public alley or public street. However, the accessory dwelling unit (ADU) daylight plane shall not be enforced if it prohibits the development of an 850 square foot ADU which is required by state law.

(3) Daylight plane shall not be enforced for an ADU if the structure abuts a city street or alleyway in the rear of the property.

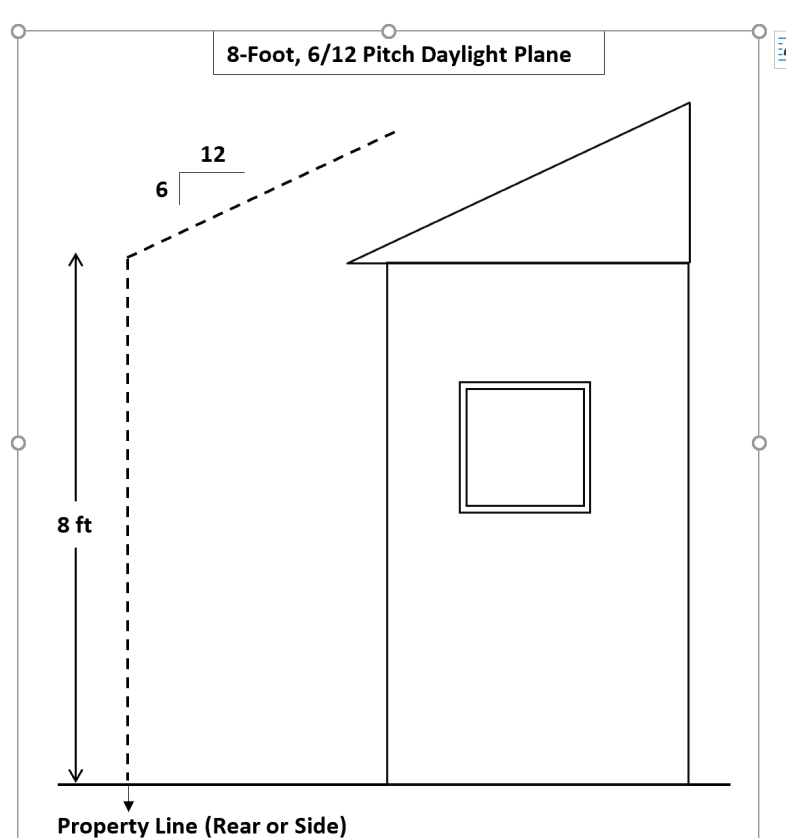

(h) A single-family residential accessory dwelling unit must be built in accordance with the building code set forth in Chapter 14, except that any design, zoning, and building standards inconsistent with state requirements under California Government Code Section 65852.2 shall not apply.

(i) Parking. One (1) additional uncovered parking space of nine feet by eighteen feet (9X18) shall be required for a newly constructed single-family residential accessory dwelling unit, which may be located within the front setback, in tandem and in an existing driveway including within an interior side yard setback area, unless a specific finding is made that such parking is

not feasible due to specific site, topographical or fire and life safety. Notwithstanding the above, a parking stall will not be required for a residential accessory dwelling unit that meets any of the following criteria:

- (1) The single-family residential accessory dwelling unit is created as a result of the conversion of existing area of the single-family residence or existing permitted residential accessory structure.
- (2) An existing garage, carport or parking structure is converted or demolished to accommodate a single-family residential accessory dwelling unit in the same location. If the required parking for the main single-family residence is removed the property owner must submit a **notarized** letter to the City acknowledging removal of said parking could create a nonconformity for future expansions of the single-family dwelling.
- (3) The single-family residential accessory dwelling unit is within one-half (1/2) mile walking distance of a public transit station, such as a bus stop or train station.
- (4) The property is within an architecturally and historically significant historic district.
- (5) On-street parking permits are required in the area but not offered to the occupant of the residential accessory dwelling unit.
- (6) A vehicle share site is located within one (1) block of the single-family residential accessory dwelling unit.
- (j) Design Standards. Architectural review of attached or detached single-family residential accessory dwelling units over **851 square feet** will be limited to the following:

(1) Notwithstanding any other provision of this code, a zoning clearance letter shall be issued for accessory dwelling units and shall be reviewed by the director of community development or their designee for compliance with objective design standards as identified within Chapter 14.06(Single Family Zoning Districts or Chapters 14.16-14.24 (Multi Family Zoning Districts). The permit shall be considered ministerial without discretionary review within the time frames required by Section 65852.2 of the Government Code; when the application is in compliance with the relevant standards, the permit shall be issued. In those instances where an applicant seeks permission to deviate from the standards, a variance shall be filed in accordance with 14.76.070. If the permit application to create an accessory dwelling unit or a junior accessory dwelling unit is submitted with a permit application to create a new single-family dwelling on the lot, the City may delay acting on the permit application for the accessory dwelling unit or the junior accessory dwelling unit until the permitting agency acts on the permit application to create the new single-family dwelling, but the application to create the accessory dwelling unit or junior accessory dwelling unit shall be considered without discretionary review or hearing. If the applicant requests a delay, the 60-day time period shall be tolled for the period of the delay

(2) The architectural features, window styles, roof slopes, exterior materials, colors, appearance, and design of the single-family residential accessory dwelling unit must be compatible with the existing single-family dwelling.

(3) Any window, door or deck of a single-family residential accessory dwelling unit must utilize design techniques to lessen views onto adjacent properties to preserve the privacy of residents. Minimum sill height of 5' (60) inches for windows on the second story within 15' of the property line that face out to the neighbors to try to mitigate privacy concerns shall be required.

(2) For accessory dwelling units that are 851 square feet or greater, the

(3) A new single-family residential accessory dwelling unit located within a historic site or neighborhood combining district will be subject to ministerial review for compliance with the design review criteria set forth in section Chapter 12.44 of the Los Altos Municipal Code and must be consistent with the Secretary of Interior's Standards for the Treatment of Historic Properties.

(4) Outside stairways serving a second story single-family residential accessory dwelling unit shall not be constructed on any building elevation facing a public street.

(5) No passageway will be required in conjunction with the construction of any single-family residential accessory dwelling unit.

(k) Streamlined Approval of Accessory Dwelling Units. Notwithstanding the restrictions above, a building permit application for a detached, single-family residential accessory dwelling unit within a residential or mixed-use zone must be a ministerial approved if it is:

(1) Setback four (4) feet from the interior side and rear lot lines; except for properties on a corner lot in which case the street side setback shall be at least twelve (12) feet.

(2) eight hundred (850) square feet in floor area; and

(3) sixteen (16) feet in height.

14.14.060 Junior accessory dwelling unit standards.

Notwithstanding any other provisions in this Article or of this chapter to the contrary, a junior accessory dwelling unit shall be permitted and comply with the following:

150 square feet can be added to a property if doing so will allow ingress/egress for a JADU

(a) Owner-occupancy of the property shall be required for junior accessory dwelling units or the main dwelling unit. The owner may reside in the primary residence, junior accessory dwelling unit or separate residential accessory dwelling unit constructed on the property in compliance with this Article.

(b) One (1) junior accessory dwelling unit may be permitted per residential lot zoned for a single-family residential use, provided that the lot has not more than one (1) existing or proposed single-family residence, and not more than one (1) attached or detached, residential accessory dwelling unit.

(c) The unit must be constructed within the existing walls of a single-family dwelling ~~or accessory structure~~, except that an expansion of 150 square feet beyond the existing physical dimensions of the accessory structure may be permitted to accommodate required ingress and egress.

(d) The square footage of the unit shall be at least the minimum size (150 square feet) required for an efficiency unit, up to a maximum size of five hundred (500) square feet in floor area, and must include one bedroom or studio sleeping area.

~~(e) The unit shall provide side and rear setbacks sufficient for fire and safety.~~

(f) A separate entrance from the unit to the exterior of the residence, and an interior connection to the main living area shall ~~shall~~ **may** be provided. A second interior doorway for sound attenuation may also be permitted.

(g) At least an efficiency kitchen must be provided in the unit which shall include all of the following:

(1) A cooking facility with appliances. Appliances can include hot plate, or counter top cooking. A property owner does not have to a wall installed oven or stove to qualify for a cooking appliances.

(2) A food preparation counter and storage cabinets that are of reasonable size in relation to the size of the junior accessory dwelling unit.

(h) The unit may include separate bathroom facilities or may share bathroom facilities contained within the primary residence.

(i) No separate utility connection, connection fee or capacity charge, or parking space shall be required for a junior accessory dwelling unit.

(j) a deed restriction shall be required for junior accessory dwelling units and must include the following stipulations:

(1) prohibition on the sale of the JADU separate from the sale of the single family residence

(2) if a JADU is rented, the unit shall not be rented for a period of less than thirty (30) consecutive days

(3) owner occupancy is required for the JADU **or the main house**, unless the owner is another government agency, land trust or housing organization as allowed by State Law.

14.14.070 Multi-family accessory dwelling unit standards.

Notwithstanding any other provisions of this chapter to the contrary, multi-family accessory dwelling units shall be permitted and comply with the following:

- (a) Portions of existing multi-family dwelling structures that are not used as livable space (including, but not limited to, storage rooms, boiler rooms, passageways, attics, basements, or garages), but excluding any residential amenities required to be provided for the facility by the zoning ordinance, or as a condition of project approval, may be converted for use as accessory dwelling units provided that total number of units must not exceed twenty-five (25) percent of the existing multi-family dwelling units or one (1) unit, whichever is greater.
- (b) An owner may also construct up to a maximum of two detached accessory dwelling units on a lot that has an existing multifamily dwelling, subject to a height limit of sixteen (16) feet and four (4) foot rear yard and side setbacks.
- (c) Accessory dwelling units in multi-family zone districts shall comply with all the standards of the zone district they are located in except for the standards provided in this Chapter.

14.14.080 Voluntary Additional Setback

For a detached accessory dwelling units, the minimum setbacks shall be five feet (5) from the house, and four feet (4) from the interior side and rear yard setbacks. However, so as to reduce the privacy impacts to neighbors if an applicant voluntarily increases the setbacks to be ten (10) feet from the rear yard and eight feet (8) from the interior side yard then the City will grant a reduced daylight plane of: Options 7 or 8 feet 5/12 6/12 1/1 8/12-provide graphics for the Commission on May 6th

SECTION 2. CONSTITUTIONALITY. If any section, subsection, sentence, clause or phrase of this code is for any reason held to be invalid or unconstitutional, such decision shall not affect the validity of the remaining portions of this code.

SECTION 3. CEQA. The City Council finds the adoption of this ordinance to be statutorily exempt from the requirements of the California Environmental Quality Act (CEQA) pursuant to Section 21080.17 of the Public Resources Code because it is an ordinance regarding second units in single-family and multifamily residential zones to implement the provisions of Government Code Section 65852.2.

SECTION 4. PUBLICATION. This ordinance shall be published as provided in Government Code section 36933. Within 15 days of the passage of this ordinance, the City Clerk shall cause the full text of the ordinance, with the names of those City Council members voting for and against the ordinance, to be published in an adjudicated newspaper. In lieu of publishing the full text of the ordinance, the City Clerk, if so directed by the City Attorney and within 15 days, shall cause a summary of the ordinance, prepared by the City Attorney and with the names of the City Council members voting for and against the ordinance, to be published in an adjudicated newspaper, and shall post in the office of the City Clerk a certified copy of the full text of the ordinance, along with the names of those City Council members voting for and against the ordinance. The publication of a summary of the ordinance in lieu of the full text of the ordinance is authorized only where the requirements of Government Code Section 36933(c)(1) are met.

SECTION 5. EFFECTIVE DATE. This ordinance shall be effective upon the commencement of the thirty-first day following the adoption date.

SECTION 6. TRANSMISSION TO HCD. The City Clerk shall send a certified copy of this ordinance to the Department of Housing and Community Development (HCD) within sixty (60) days after adoption, as required by state law.

The foregoing ordinance was duly and properly introduced at a regular meeting of the City Council of the City of Los Altos held on _____, 2020 and was thereafter, at a regular meeting held on _____, 2020 passed and adopted by the following vote:

- AYES:
- NOES:
- ABSENT:
- ABSTAIN:

Janis C. Pepper, MAYOR

Attest:

Jon Maginot, CMC, CITY CLERK

8-Foot, 6/12 Pitch Daylight Plane

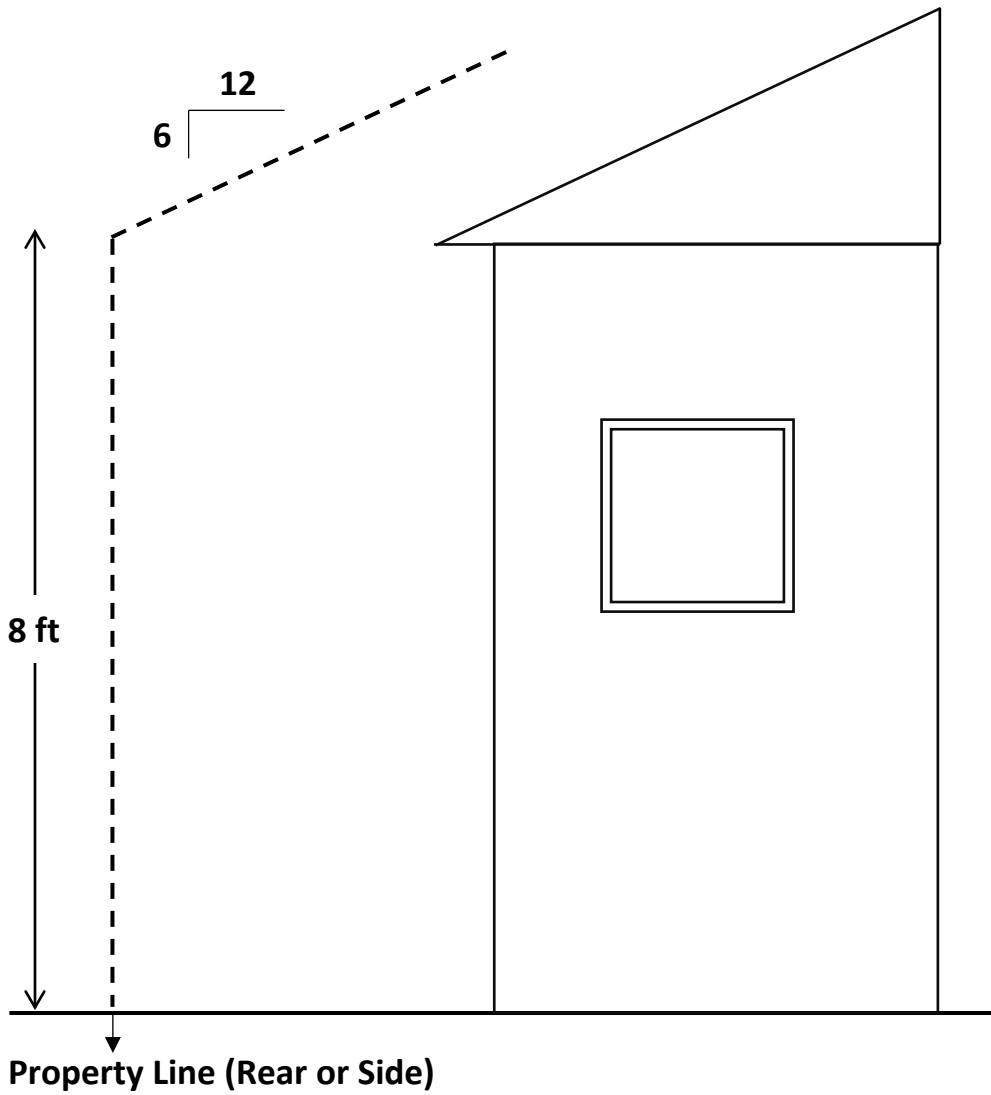

8-Foot, 5/12 Pitch Daylight Plane

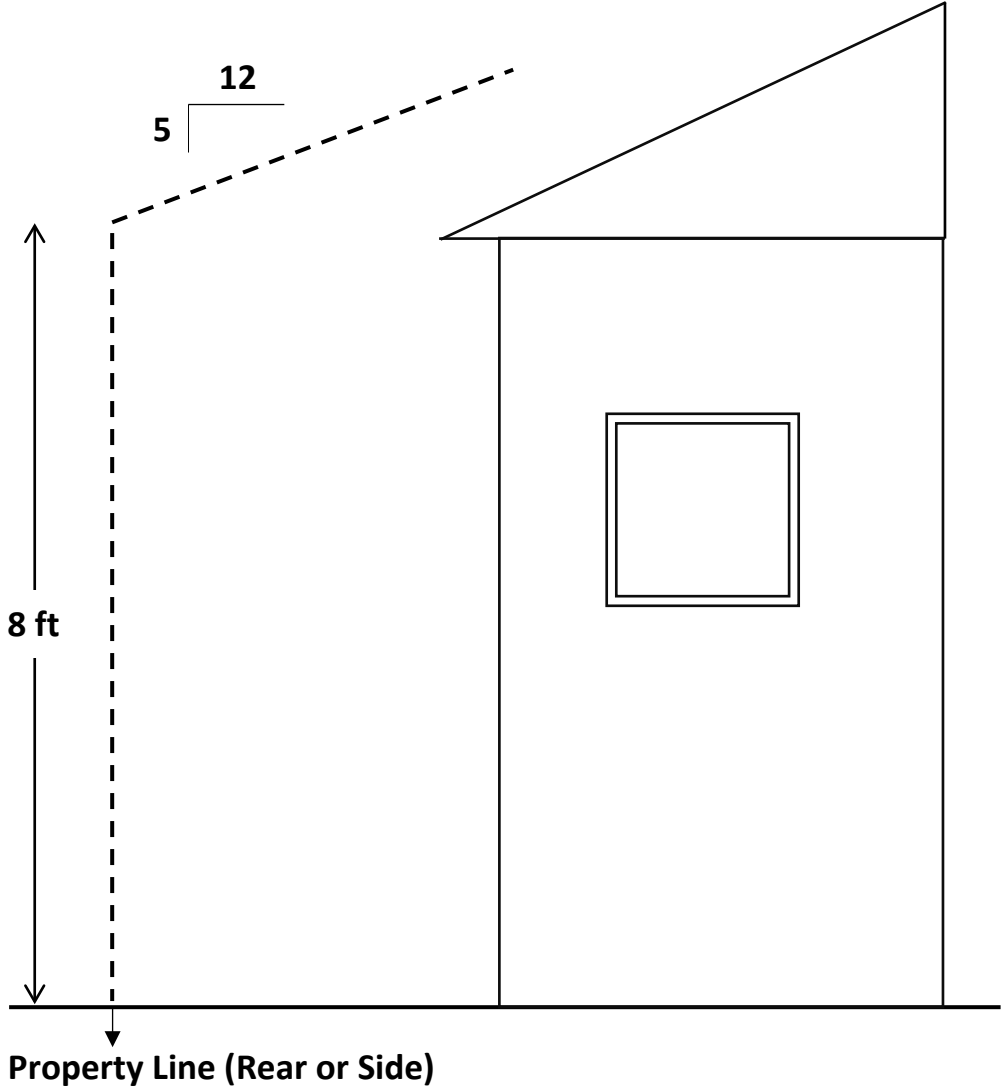

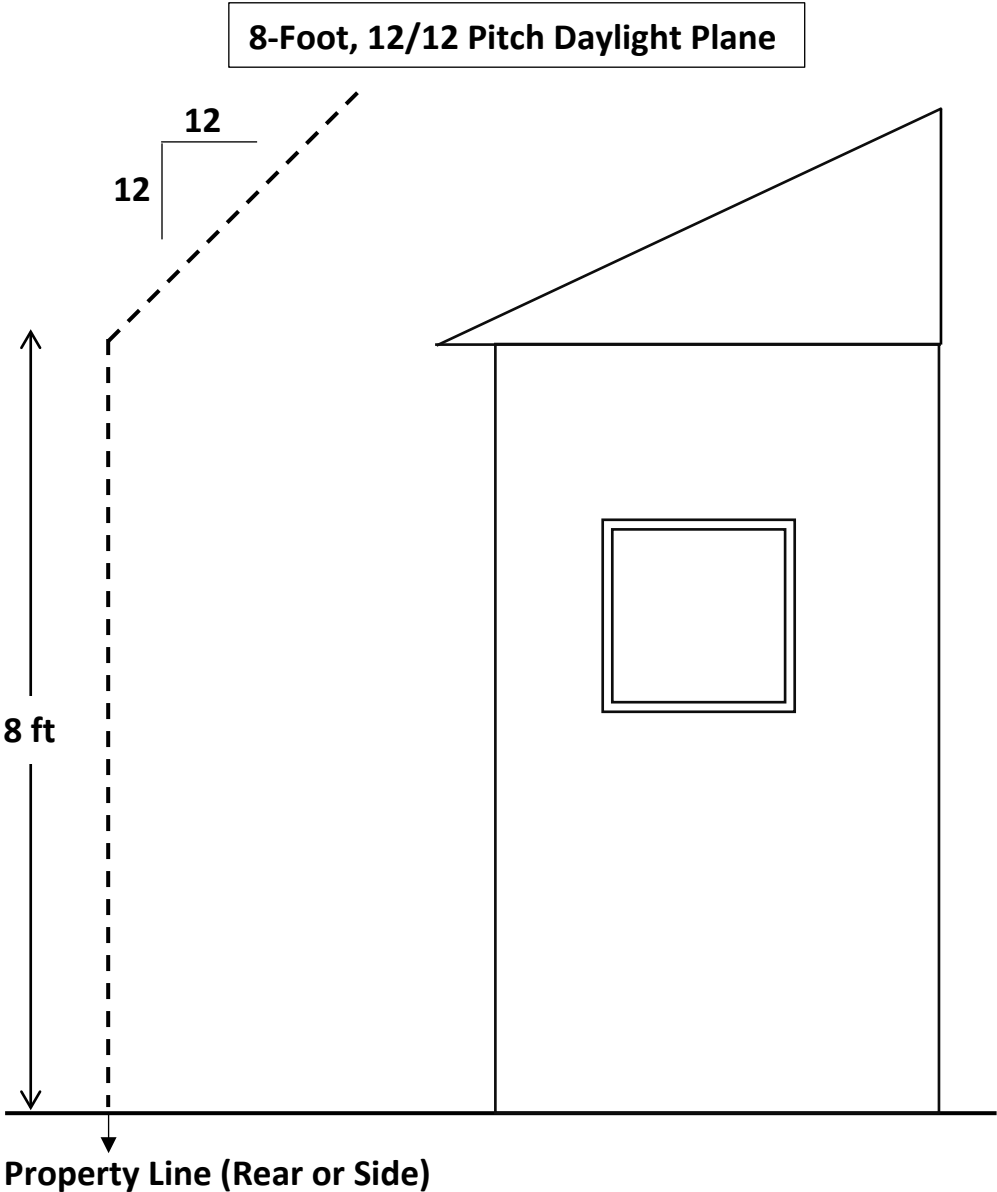

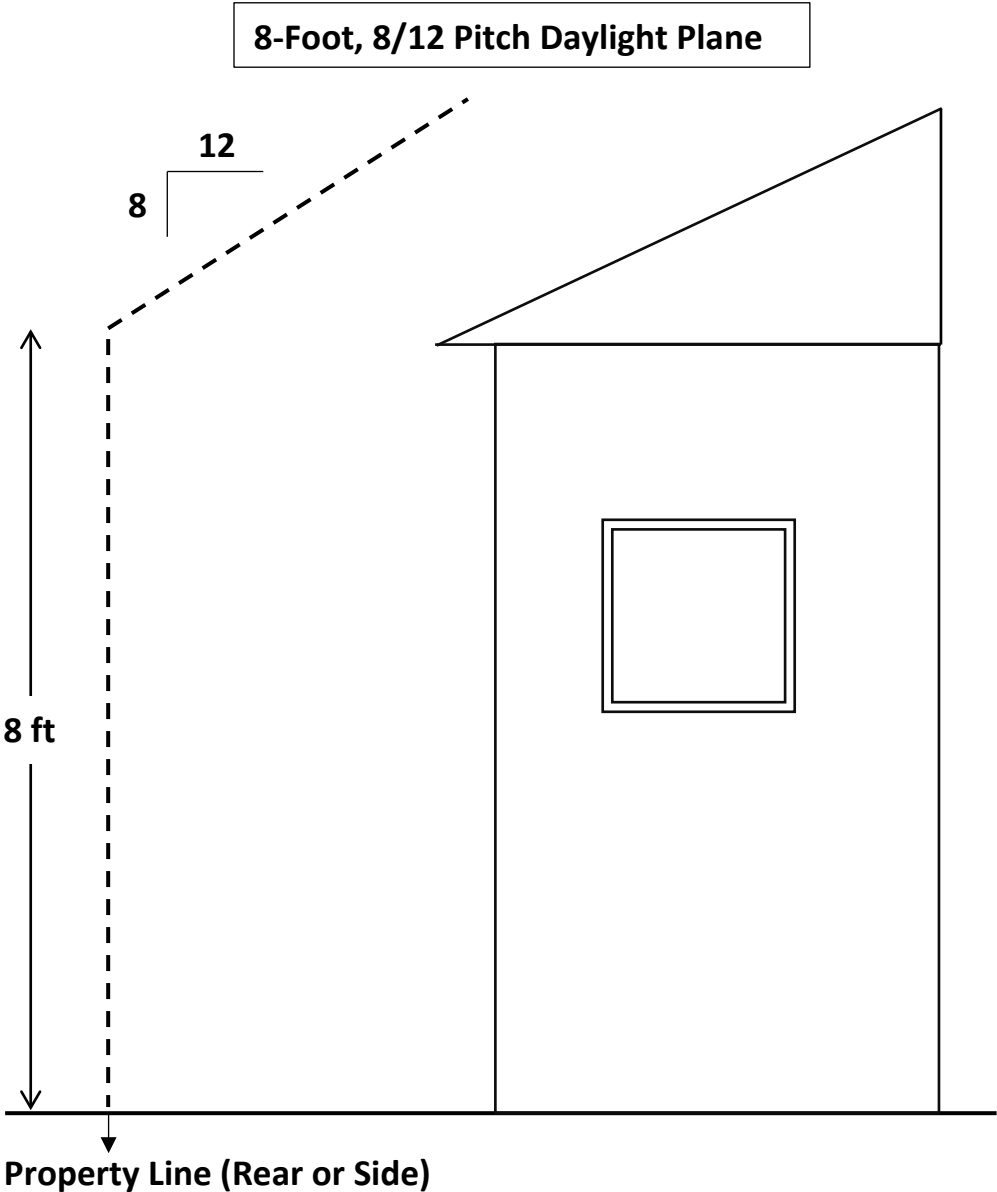

7-Foot, 5/12 Pitch Daylight Plane

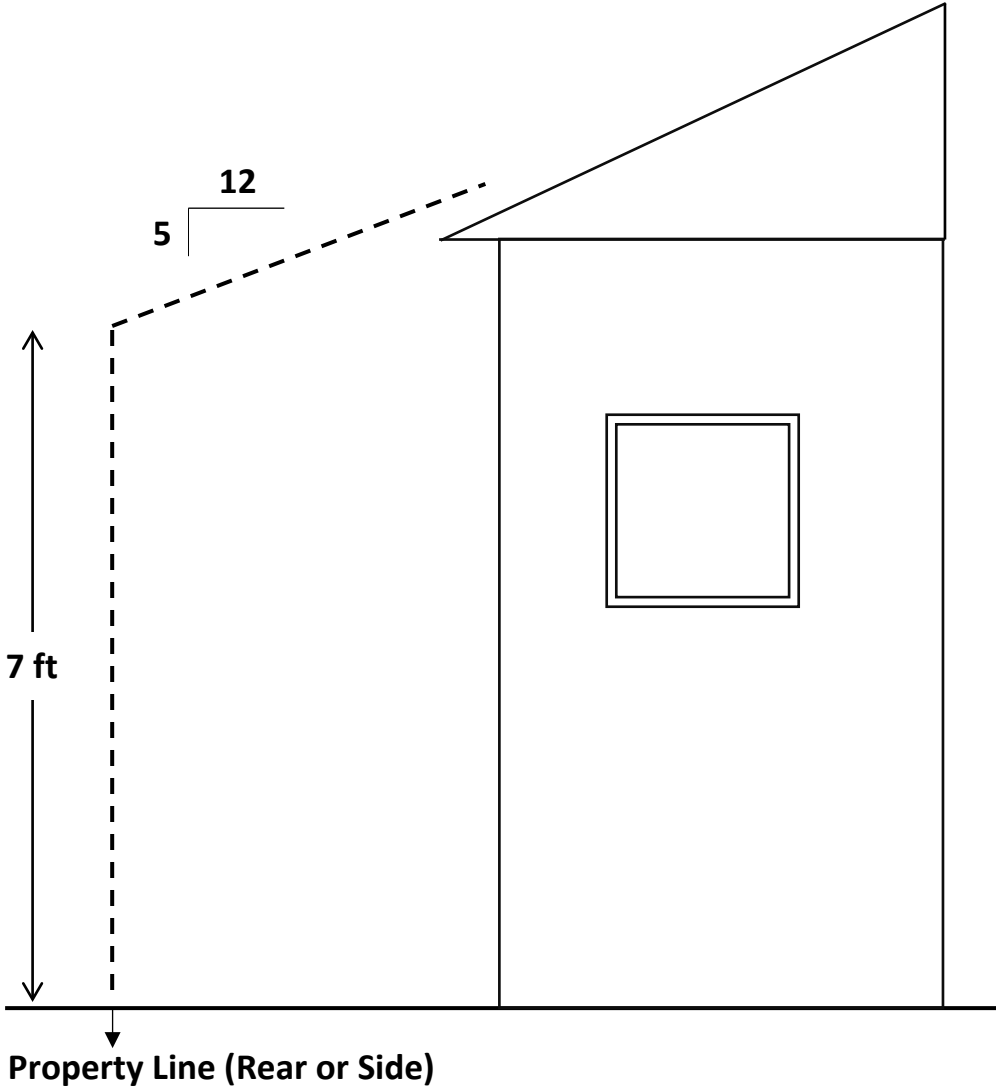

7-Foot, 6/12 Pitch Daylight Plane

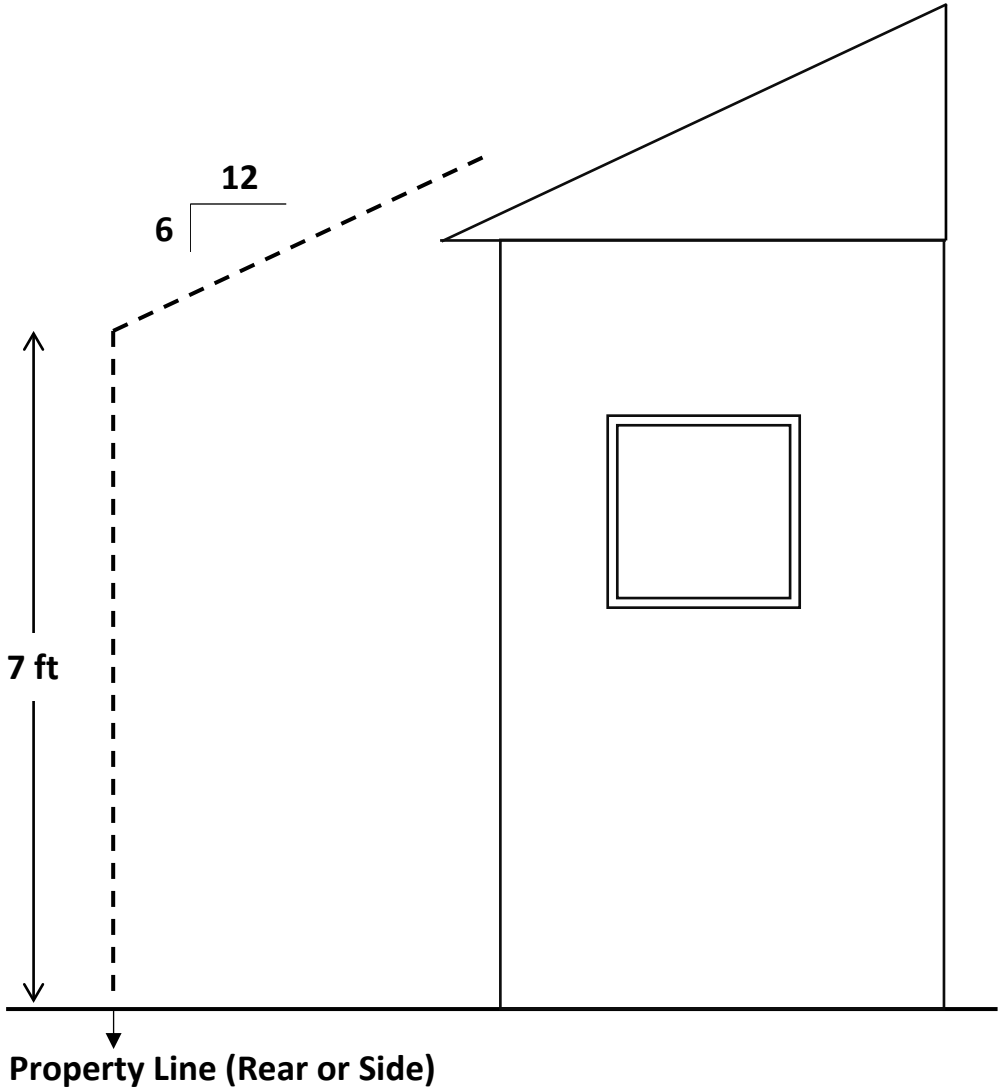

7-Foot, 12/12 Pitch Daylight Plane

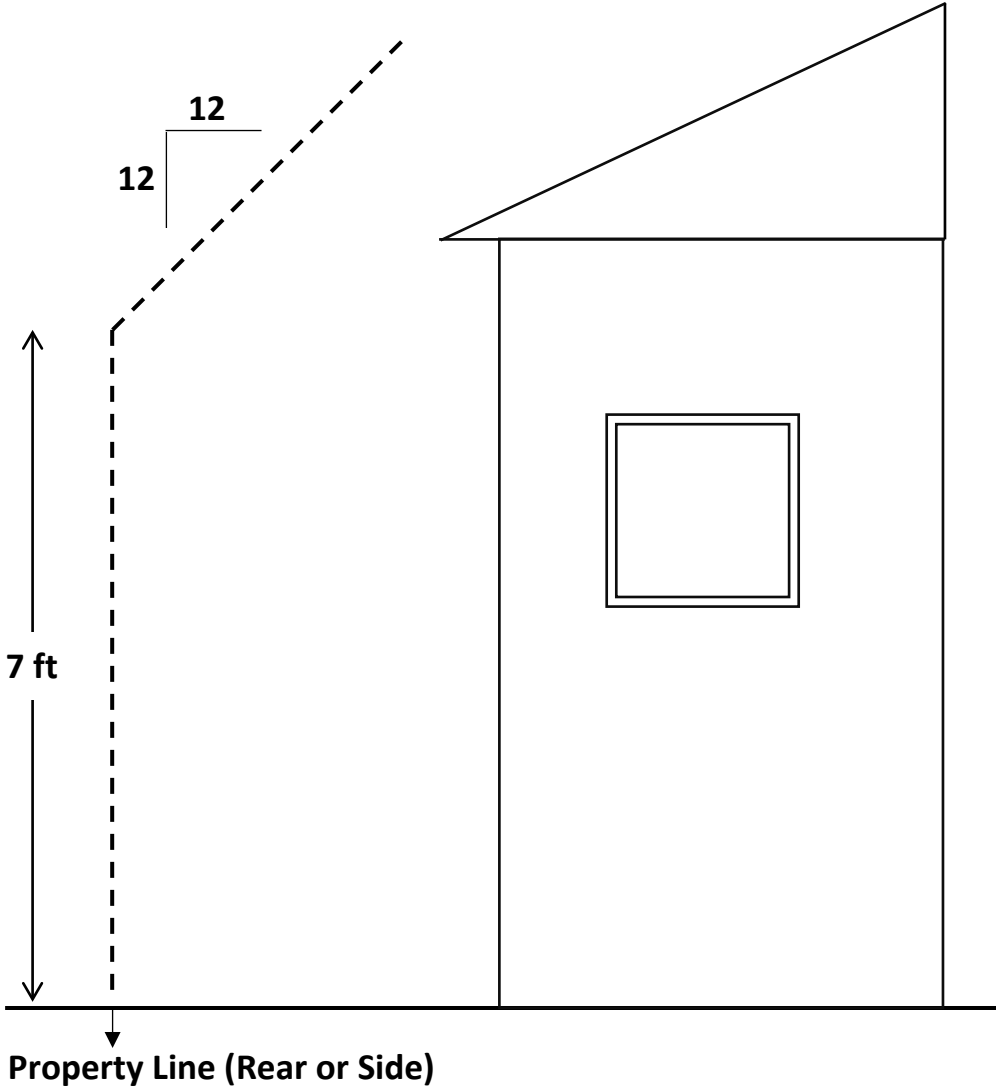

7-Foot, 8/12 Pitch Daylight Plane

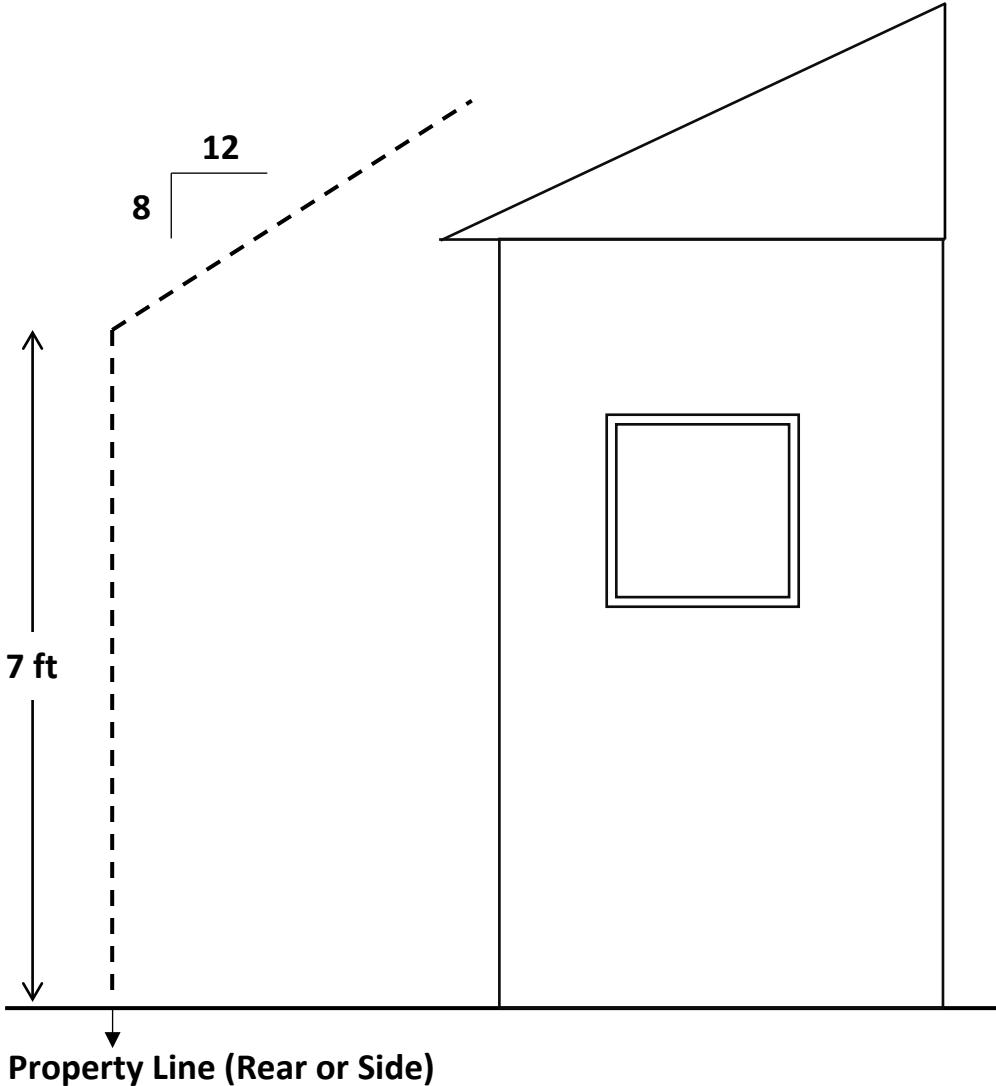



_____ CALENDAR

Agenda Item # ____

AGENDA REPORT SUMMARY

Meeting Date: April 16, 2020

Subject: Repeal and Replace Chapter 14.14 of the Los Altos Municipal Code (Accessory and Junior Dwelling Units)

Prepared by: Guido F. Persicone, Planning Services Manager, AICP

Review by: Jon Biggs, Community Development Director

Approved by: Chris Jordan, City Manager

Attachment(s):

A. Draft ADU Ordinance

Initiated by:

City staff

Previous Council Consideration:

2018

Fiscal Impact:

No direct fiscal impact is anticipated

Environmental Review:

Adoption of an accessory dwelling unit ordinance is subject to a statutory exemption from environmental review (Public Resource Code Section 15282(h)). In addition, the action being considered does not constitute a “project” within the meaning of the California Environmental Quality Act (“CEQA”) pursuant to CEQA Guidelines Section 15061(b)(3) as the activity is covered by the general rule that CEQA applies only to projects which have the potential for causing a significant effect on the environment. Where it can be seen with certainty that there is no possibility that the activity in question may have a significant effect on the environment, the activity is not subject to CEQA. Projects that are subject to the ADU regulations will be evaluated pursuant to CEQA on an individual basis. However, ADUs are generally exempt from CEQA review under CEQA Guidelines Section 15301 (Existing Facilities) and/or Section 15303 (New Construction or Conversion of Small Structures).

Policy Question(s) for Council Consideration:

- Do the proposed code amendments ensure the Los Altos Municipal Code is consistent with recent changes to state law?



Subject: Proposed Amendments to the Chapter 14.14 (Accessory Dwelling Unit) Ordinance

Summary:

- The ordinance repeals and replaces Chapter 14.14, Accessory Dwelling Units, to ensure consistency with State law.

Staff Recommendation:

Staff suggests that the Planning Commission recommend adoption of the proposed ordinance to the City Council.

Purpose

The purpose of the proposed amendments is to ensure compliance with new state laws affecting the development of accessory dwelling unit and junior accessory dwelling units in the residential zone districts of the City.

Background

Prior to 2016, cities could regulate and permit Accessory Dwelling Units (ADU) based on local preferences. State legislation passed between 2015-2019 has removed most local control on ADUs and requires jurisdictions to allow ADUs in most single-family zoning districts, and now in multifamily zoning districts as well. Additionally, there are now several circumstances where “by-right” ADUs must be allowed through the issuance of a building permit only. The City’s Zoning Code has been amended several times since 2016 to address past changes in State law, and these proposed amendments are for the same purpose.

Staff has performed a consistency review of the Zoning Code (Title 14 of the Los Altos Municipal Code (LAMC) in comparison to the new legislation (AB 881, AB 68, and SB 13) and has identified necessary modifications to bring the zoning code into conformance resulting in a new LAMC Section 14.14 (Accessory Dwelling Units And Junior Dwelling Units). The major changes as a result of the state legislation include:

JADUs. Cities are now required to allow Junior ADUs (JADUs), which are small ADUs (up to 500 square feet) within an existing or proposed single-family dwelling.¹ JADUs are not considered separate dwellings for purposes of fire and life safety requirements that would otherwise apply to standard ADUs. The proposed ordinance creates new definitions for “standard accessory dwelling units” and “junior accessory dwelling units”.

Streamlined Approval of Certain ADUs/JADUs. The legislature expanded the categories of ADUs that must be approved with a building permit only. These include “interior space conversions” in both single-family dwellings and multi-family structures, and detached units up to

¹ The JADU can be within the confines of a proposed house per GC section 65852.2



Subject: Proposed Amendments to the Chapter 14.14 (Accessory Dwelling Unit) Ordinance

800 square feet in size and 16 feet in height with minimum 4-foot side and rear yard setbacks. The setbacks may be less than 4 feet if the ADU replaces and exactly replicates the size and footprint of an existing structure that was demolished to build the ADU.

Multi-family Dwellings. A lot containing an existing multifamily dwelling structure can include two detached ADUs up to 800 square feet in size and 16 feet in height. In addition, non-livable space within the multifamily structure can be converted to ADUs equal to 25% of the number of existing dwelling units in the structure, as long as the ADUs can be constructed to meet building codes².

JADU + Detached ADU. One JADU can now be combined with one detached ADU on a single-family lot, meeting certain requirements, resulting in 3 dwelling units on a site with one single-family dwelling.

No Owner-Occupancy Restrictions. The legislation invalidates owner-occupancy restrictions on standard ADUs until 2025, but owner-occupancy restrictions are mandatory for JADUs (this is a potential conflict between the statutes that might be further clarified with clean-up legislation).

Use of ADUs as Short-Term Rentals. The legislation prohibits ADUs from being used as short-term rentals (STRs), which is less than 30 days.

Parking. The City can no longer require replacement parking when a garage or carport is demolished to create an ADU. In addition, no off-street parking is required for JADUs or ADUs that qualify for streamlined approval. Finally, no parking is required of any ADU that meets various statutory exceptions, including an ADU within ½ mile walking distance of any bus stop

Correction of Zoning Violations. The City cannot require that the applicant correct existing zoning violations on the property as a condition of granting a permit to build an ADU. Independent of issuing the permit for the ADU the City can still pursue code enforcement of zoning violations.

² GC Section 65852.2 (ii) A local agency shall allow at least one accessory dwelling unit within an existing multifamily dwelling and shall allow up to 25 percent of the existing multifamily dwelling units. (D) Not more than two accessory dwelling units that are located on a lot that has an existing multifamily dwelling, but are detached from that multifamily dwelling and are subject to a height limit of 16 feet and four-foot rear yard and side setbacks.



Subject: Proposed Amendments to the Chapter 14.14 (Accessory Dwelling Unit) Ordinance

Timing. The City must act on ADU applications within 60 days of the project being deemed complete by the City.

Utilities and Impact Fees. Separate utility connections and associated fees and charges cannot be imposed on JADUs or standard ADUs converted from existing interior space, unless the ADU is proposed as part of a new single-family dwelling. All impact fees must be proportional to the size of the ADU. In addition, ADUs up to 750 square feet are exempt from impact fees, including traffic impact fees.

Delay of Building Permit Enforcement. Until 2030, owners of existing ADUs may request a 5-year delay in enforcement of building codes applicable to an ADU. This request must be granted unless the building standard is necessary to protect life and safety.³

Discussion/Analysis

Due to the wide breadth of changes required by state law, including provisions of Junior ADUs (JADUs) and the fact that the current ordinance does not actually provide setback or daylight plane provisions for ADUs but rather relies on the Accessory Structure Ordinance, City staff are recommending that the entire ordinance be repealed and replaced. Please note that the City Attorney is currently reviewing the draft ordinance. Additional edits are forthcoming and will be provided to the Planning Commission and interested parties prior to the meeting.

Los Altos General Plan Conformance

General Plan Land Use Goal 2: Review and amend (as needed) the Zoning Ordinance to provide consistency with new state legislation and court decisions. Consider Zoning Ordinance amendments that implement the use and development of goals, policies and plan objectives for the identified planning areas (Downtown, El Camino Real Corridor, and Foothill Plaza).

Housing Element Policy 4.2: The City will encourage the development of affordable second dwelling units that conform to zoning regulations.

Program 4.2.1 – Facilitate new construction of second dwelling units.

Program 4.2.2-Study the feasibility of reducing minimum lot sizes for second living units.

Options

- 1) Recommend approval of the draft ordinance to the City Council.

³ HSC 17980.12 (ii) 17980.12. (a) (1)



Subject: Proposed Amendments to the Chapter 14.14 (Accessory Dwelling Unit) Ordinance

Advantages: Ensure compliance with new state laws.

Disadvantages: Results in less control over accessory dwelling units in Los Altos.

2) Recommend denial of the draft ordinance to the City Council

Advantages: There is no advantage to denying this ordinance as noncompliance with State law is not a viable position for a municipal agency to be in.

Recommendation

The staff recommends Option 1.

ORDINANCE NO. 2020-___

**AN ORDINANCE OF THE CITY COUNCIL OF THE CITY OF LOS ALTOS
REPEALING AND REPLACING THE ACCESSORY DWELLING UNIT
ORDINANCE AND MAKING FINDINGS OF CEQA EXEMPTION**

WHEREAS, the State Legislature has found that accessory dwelling units are a necessary and valuable form of housing in California; and

WHEREAS, accessory dwelling units help diversify the City's housing stock and help provide rental units that are affordable; and

WHEREAS, accessory dwelling units offer lower cost housing to meet the needs of existing and future residents within existing neighborhoods, while respecting neighborhood character; and

WHEREAS, accessory dwelling units provide housing for family members, students, the elderly, in-home health care providers, the disabled, and others within existing neighborhoods; and

WHEREAS, it is the intent of this ordinance to allow and promote the development of accessory dwelling units; and

WHEREAS, this Ordinance implements Program 4.2.1 and Program 4.2.2 of the City's 2015-2023 Housing Element by facilitating the development of new accessory dwelling units; and

WHEREAS, this Ordinance is exempt from environmental review pursuant to Section 15061 and Section 15301 of the California Environmental Quality Act Guidelines, as amended.

NOW THEREFORE, the City Council of the City of Los Altos does hereby ordain as follows:

SECTION 1. AMENDMENT OF CODE: Chapter 14.14 of Title 14 of the Los Altos Municipal Code is hereby repealed in its entirety and replaced with the new standards and shall read as follows:

Section 14.14.010 Purpose and Intent.

The intent of this chapter is to provide for accessory dwelling units and junior accessory dwelling units, collectively known as an accessory dwelling, on lots zoned to allow single-family or multifamily dwelling residential use that include a proposed or existing dwelling. Accessory dwelling units contribute needed housing to the City of Los Altos housing stock and enhance housing opportunities. An accessory dwelling unit is considered a residential use

that is consistent with the existing general plan and zoning designations for the lot. The accessory dwelling unit is not included in calculation of residential density for the purposes of determining general plan conformance.

14.14.020 Definitions.

As used in this section, the following terms mean:

“Accessory dwelling unit” means an attached or a detached residential dwelling unit that provides complete independent living facilities for one or more persons and is located on a lot with a proposed or existing primary residence. It shall include permanent provisions for living, sleeping, eating, cooking, and sanitation on the same parcel as the single-family or multi-family dwelling is or will be situated. An accessory dwelling unit also includes the following:

(A) An efficiency unit, as defined in Section 17958.1 of the Health and Safety Code.

(B) A manufactured home, as defined in Section 18007 of the Health and Safety Code.

“Attached accessory dwelling unit” means a residential dwelling unit that is created as a result of internal conversion, addition, or combination thereof made to the primary residential dwelling unit.

“Multi-family housing” means a dwelling unit or group of dwelling units on one site that contains separate living units for two or more families that may have joined services or facilities or both.

“Junior accessory dwelling unit” means a unit that is no more than 500 square feet in size, includes an efficiency kitchen consistent with building code standards, is contained entirely within the walls of a single-family residence or multi-family building, and may include separate sanitation facilities or may share sanitation facilities with the existing structure or unit.

“Living area” means the interior habitable area of a dwelling unit, including basements and attics, but does not include a garage or any accessory structure.

“Nonconforming zoning condition” means a physical improvement on a property that does not conform with current zoning standards.

“Public transit” means a location, including, but not limited to, a bus stop or train station, where the public may access buses, trains, subways, and other forms of transportation that charge set fares, run on fixed routes, and are available to the public.

“Tandem parking” means that two or more automobiles are parked in any location on a lot and lined up behind one another.

Section 14.14.030 Location Permitted

Accessory dwelling units may be permitted in the following zones:

1. Single-family district (R1-10);
2. Single-family district (R1-H);
3. Single-family district (R1-20);
4. Single-family district (R1-40);
5. Multiple-family district (R3-4.5);
6. Multiple-family district (R3-5);
7. Multiple-family district (R3-3);
8. Multiple-family district (R3.1.8); and
9. Multiple-family district (R3-1).
10. Properties zoned for mixed uses (CD/R3)

B. Nothing in this chapter shall be construed to authorize construction of new single-family residences in multiple-family districts where such single-family residential use is not otherwise allowed.

14.14.040 General Requirements.

Notwithstanding any local ordinance regulating the issuance of variances or special use permits, or regulations adopted herein to the contrary, an application for a building permit to construct an accessory dwelling unit, or junior accessory dwelling unit, or efficiency unit (“accessory dwelling”) shall be approved or denied ministerial without discretionary review or hearing within sixty (60) days from the date the city receives a completed application if there is an existing single-family or multifamily structure on the lot. The following requirements apply to all accessory dwellings:

- (a) An accessory dwelling shall not be rented for periods less than thirty (30) days. Short term rentals are prohibited.
- (b) Except for a Junior Accessory dwelling unit as allowed by State law, an accessory dwelling shall not be sold or have its title transferred separately from the primary residential structure.
- (c) Deed Restriction. Prior to the issuance of the building permit for the accessory dwelling unit, the owner must record a deed restriction stating that the accessory dwelling unit may not be rented for periods less than thirty (30) days, that it may not be transferred or sold separate from the primary residential structure,
- (d) The installation of fire sprinklers shall not be required for an accessory dwelling if sprinklers are not required for the primary residence.
- (e) Accessory dwellings are subject to the design standards and other zoning requirements of the zoning district in which the existing single-family dwelling is located and must be built in accordance with the building code set forth in Chapter 6 of the Los Altos Municipal Code, except for those design, zoning, and building standards inconsistent with state requirements under California Government Code Section 65852.2.

- (f) An accessory dwelling is not subject to residential accessory structure regulations.
- (g) An accessory dwelling will not be subject to any charges and fees other than building permit fees generally applicable to residential construction in the zone in which the property is located, except as otherwise provided herein.
- (h) Any connection fees and capacity charges that may be required must be assessed in compliance with the provisions of State Government Code Section 65852.2 and 65852.22, and as the sections may be amended over time by the State.
- (i) The accessory dwelling must contain water, sewer and gas and/or electric utility connections that are in working condition upon its occupancy. The accessory dwelling may be serviced by the primary residence or may have separate utility meters. The accessory dwelling will not be considered a new residential use for the purpose of calculating connection fees or capacity charges for these utilities.
- (j) An accessory dwelling unit must have an independent electrical sub-panel, water heating and space heating equipment within the unit or be readily accessible to the occupant on the exterior of the unit.
- (k) Ministerial approval of a permit for creation of an accessory dwelling shall not be conditioned on the correction of pre-existing nonconforming zoning conditions.
- (l) A certificate of occupancy for any accessory dwelling shall not be issued before the local agency issues a certificate of occupancy for the primary dwelling.
- (m) If the applicant requests a delay in processing, the 60-day time period shall be tolled for the period of the delay.

14.14.050 Single-Family Residential Accessory Dwelling Unit Standards

Notwithstanding any other provisions of this chapter to the contrary, a single-family residential accessory dwelling unit shall be a permitted as a single-family residential use that shall comply with the following:

- (a) Zoning. A single-family residential accessory dwelling unit shall be located in a residential or mixed-use zone district that permits single-family residential development of the lot.
- (b) Number. Only one (1) detached single-family residential accessory dwelling unit may be permitted on a parcel that contains not more than one existing or proposed single-family residence.
- (c) Relationship to Primary Dwelling. A single-family residential accessory dwelling unit may be within, attached to, or detached from, the proposed or existing primary dwelling, provided that:

(1) A single-family residential accessory dwelling unit contained within or attached to an existing primary dwelling unit shall have independent exterior access from the existing residence; and

(2) A detached single-family residential accessory dwelling unit must be located at least five (5) feet from the proposed primary dwelling.

(d) Size.

(1) A studio or one (1) bedroom, attached or detached single-family residential accessory dwelling unit shall be permitted, and limited to eight hundred (800) square feet in floor area, garage areas excluded.

(2) An attached or detached single-family residential accessory dwelling unit with more than one bedroom shall be permitted, and limited to twelve hundred (1,200) square feet in floor area, garage areas excluded.

i. The total floor area for an attached accessory dwelling unit shall not exceed one thousand two hundred (1,200) square feet, excluding the basement areas, and shall not be more than fifty (50) percent of the floor area of the existing or proposed principal residence.

ii. The total floor area for a detached accessory dwelling unit shall not exceed one thousand two hundred (1,200) square feet, including basement areas, and shall not be more than fifty (50) percent of the floor area of the existing or proposed principal residence.

(3) Notwithstanding the size restrictions provided above, the total floor area of an attached single-family residential accessory dwelling unit, including internal conversions of existing primary living space, shall not exceed fifty (50) percent of the existing or proposed primary dwelling gross floor area, not including the garage. For internal conversions, the accessory dwelling unit floor area shall not exceed fifty (50) percent of the primary residential living space, after conversion.

(e) Height.

(1) The maximum height for a detached single-family residential accessory dwelling unit shall be one-story and sixteen (16) feet.

(2) The maximum height of a single-family residential accessory dwelling unit that is proposed to be constructed above a detached garage shall be twenty-four (24) feet.

(3) Attached single-family residential accessory dwelling units shall comply with the height limits established for the primary residential structure.

(f) Setbacks. A single-family residential accessory dwelling unit is subject to the design criteria and zoning requirements of the district in which the existing single-family dwelling is located and as follows:

(1) A single-family residential accessory dwelling unit must not encroach upon the required front or street side yard area.

(2) A setback of four (4) feet from the interior side and rear lot lines shall be required for a newly constructed, detached single-family residential accessory dwelling unit that is not constructed in the same location and to the same dimensions as an existing structure. Proposed structures that are four (4) feet or less from the property line shall be required to provide a record survey to the City for proof of setbacks and existing property lines.

(3) The side yard setback shall be no less than 12 feet for an attached or detached accessory dwelling unit that is abutting a city street or alleyway.

(4) The separation from the main house and any other accessory structure on the lot shall be at least five (5) feet unless implementation of this requirement would prohibit the construction of an 800 square foot detached accessory dwelling unit, in which case this requirement shall be waived to be no less than three feet (3).

(5) No additional zoning setback is required for conversion of an existing permitted accessory structure, living area, or garage space, or conversion of a structure that is constructed in the same location and to the same dimensions as the existing structure.

(g) Detached Accessory Dwelling Unit Daylight Plane

(1) No portion of an attached or detached accessory dwelling unit shall extend above or beyond a daylight plane as follows:

(2) The daylight plane starts at a height of seven feet at the property line and proceeds inward at a 5:12 slope to a distance of ten (10) feet from the side and rear property lines. All appurtenances, including chimneys, vents and antennas, shall be within the daylight plane. The daylight plane is not applied to a side or rear property line when it abuts a public alley or public street. However, the accessory dwelling unit (ADU) daylight plane shall not be enforced if it prohibits the development of an 800 square foot ADU which is required by state law.

(3) Daylight plane shall not be enforced for an ADU if the structure abuts a city street or alleyway in the rear of the property.

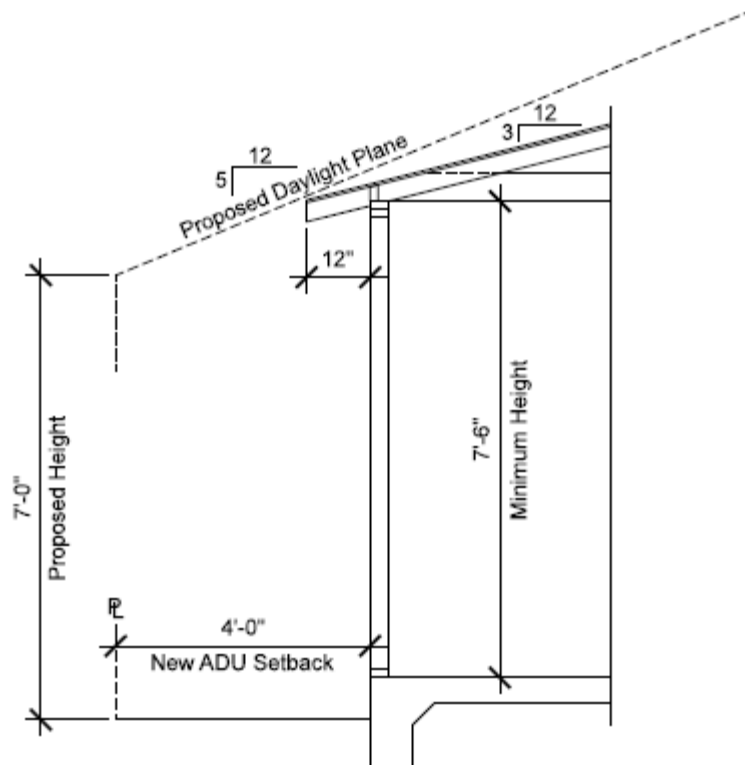

(h) A single-family residential accessory dwelling unit must be built in accordance with the building code set forth in Chapter 6, except that any design, zoning, and building standards inconsistent with state requirements under California Government Code Section 65852.2 shall not apply.

(i) Parking. One (1) additional parking space shall be required for a newly constructed single-family residential accessory dwelling unit, which may be located within the front setback, in tandem and in an existing driveway. Notwithstanding the above, a parking stall will not be required for a residential accessory dwelling unit that meets any of the following criteria:

(1) The single-family residential accessory dwelling unit is created as a result of the conversion of existing area of the single-family residence or existing permitted residential accessory structure.

(2) An existing garage, carport or parking structure is converted or demolished to accommodate a single-family residential accessory dwelling unit in the same location. If the required parking for the main single-family residence is removed the property owner must submit a letter to the City acknowledging removal of said parking could create a nonconformity for future expansions of the single-family dwelling.

(3) The single-family residential accessory dwelling unit is within one-half (1/2) mile walking distance of a public transit station, such as a bus stop or train station.

(4) The property is within an architecturally and historically significant historic district.

(5) On-street parking permits are required in the area but not offered to the occupant of the residential accessory dwelling unit.

(6) A vehicle share site is located within one (1) block of the single-family residential accessory dwelling unit.

(j) Design Standards. Architectural review of attached or detached single-family residential accessory dwelling units will be limited to the following:

(1) The architectural features, window styles, roof slopes, exterior materials, colors, appearance, and design of the single-family residential accessory dwelling unit must be compatible with the existing single-family dwelling.

(2) Any window, door or deck of a single-family residential accessory dwelling unit must utilize design techniques to lessen views onto adjacent properties to preserve the privacy of residents.

(3) A single-family residential accessory dwelling unit located within a historic site or neighborhood combining district will be subject to ministerial review for compliance with the design review criteria set forth in section Chapter 12.44 of the Los Altos Municipal Code and must be consistent with the Secretary of Interior's Standards for the Treatment of Historic Properties.

(4) Outside stairways serving a second story single-family residential accessory dwelling unit shall not be constructed on any building elevation facing a public street.

(5) No passageway will be required in conjunction with the construction of any single-family residential accessory dwelling unit.

(k) Streamlined Approval of Accessory Dwelling Units. Notwithstanding the restrictions above, a building permit application for a detached, single-family residential accessory dwelling unit within a residential or mixed-use zone must be ministerially approved if it is:

(1) Setback four (4) feet from the interior side and rear lot lines; except for properties on a corner lot in which case the street side setback shall be at least twelve (12) feet.

(2) eight hundred (800) square feet in floor area; and

(3) sixteen (16) feet in height.

14.14.060 Junior accessory dwelling unit standards.

Notwithstanding any other provisions in this Article or of this chapter to the contrary, a junior accessory dwelling unit shall be permitted and comply with the following:

(a) Owner-occupancy of the property shall be required for junior accessory dwelling units. The owner may reside in the primary residence, junior accessory dwelling unit or separate residential accessory dwelling unit constructed on the property in compliance with this Article.

(b) One (1) junior accessory dwelling unit may be permitted per residential lot zoned for a single-family residential use, provided that the lot has not more than one (1) existing or proposed single-family residence, and not more than one (1) attached or detached, residential accessory dwelling unit.

(c) The unit must be constructed within the existing walls of a single-family dwelling or accessory structure, except that an expansion of 150 square feet beyond the existing physical dimensions of the accessory structure may be permitted to accommodate required ingress and egress.

(d) The square footage of the unit shall be at least the minimum size (150 square feet) required for an efficiency unit, up to a maximum size of five hundred (500) square feet in floor area, and must include one bedroom or studio sleeping area.

(e) The unit shall provide side and rear setbacks sufficient for fire and safety.

(f) A separate entrance from the unit to the exterior of the residence, and an interior connection to the main living area shall be provided. A second interior doorway for sound attenuation may also be permitted.

(g) At least an efficiency kitchen must be provided in the unit which shall include all of the following:

(1) A cooking facility with appliances.

(2) A food preparation counter and storage cabinets that are of reasonable size in relation to the size of the junior accessory dwelling unit.

(h) The unit may include separate bathroom facilities or may share bathroom facilities contained within the primary residence.

(i) No separate utility connection, connection fee or capacity charge, or parking space shall be required for a junior accessory dwelling unit.

(j) a deed restriction shall be required for junior accessory dwelling units and must include the following stipulations:

(1) prohibition on the sale of the JADU separate from the sale of the single family residence

(2) if a JADU is rented, the unit shall not be rented for a period of less than thirty (30) consecutive days

(3) owner occupancy is required for the JADU, unless the owner is another government agency, land trust or housing organization as allowed by State Law.

14.14.070 Multi-family accessory dwelling unit standards.

Notwithstanding any other provisions of this chapter to the contrary, multi-family accessory dwelling units shall be permitted and comply with the following:

(a) Portions of existing multi-family dwelling structures that are not used as livable space (including, but not limited to, storage rooms, boiler rooms, passageways, attics, basements, or garages), but excluding any residential amenities required to be provided for the facility by the zoning ordinance, or as a condition of project approval, may be converted for use as accessory dwelling units provided that total number of units must not exceed twenty-five (25) percent of the existing multi-family dwelling units or one (1) unit, whichever is greater.

(b) An owner may also construct up to a maximum of two detached accessory dwelling units on a lot that has an existing multifamily dwelling, subject to a height limit of sixteen (16) feet and four (4) foot rear yard and side setbacks.

(c) Accessory dwelling units in multi-family zone districts shall comply with all the standards of the zone district they are located in except for the standards provided in this Chapter.

14.14.080 Additional Setback Fee Waiver Requirement

For a detached accessory structure the minimum setbacks shall be five feet (5) from the house, and four feet (4) from the interior side and rear yard setbacks. If the property is a corner lot the street side setback shall be twelve feet (12). However, so as to reduce the privacy impacts to neighbors if an applicant voluntarily increases the setbacks to be ten (10) feet from the rear yard and eight feet (8) from the interior side yard the Building Division will expediate the plan check review for this building permit application

SECTION 2. CONSTITUTIONALITY. If any section, subsection, sentence, clause or phrase of this code is for any reason held to be invalid or unconstitutional, such decision shall not affect the validity of the remaining portions of this code.

SECTION 3. CEQA. The City Council finds the adoption of this ordinance to be statutorily exempt from the requirements of the California Environmental Quality Act (CEQA) pursuant to Section 21080.17 of the Public Resources Code because it is an ordinance regarding second units in single-family and multifamily residential zones to implement the provisions of Government Code Section 65852.2.

SECTION 4. PUBLICATION. This ordinance shall be published as provided in Government Code section 36933. Within 15 days of the passage of this ordinance, the City Clerk shall cause the full text of the ordinance, with the names of those City Council members

voting for and against the ordinance, to be published in an adjudicated newspaper. In lieu of publishing the full text of the ordinance, the City Clerk, if so directed by the City Attorney and within 15 days, shall cause a summary of the ordinance, prepared by the City Attorney and with the names of the City Council members voting for and against the ordinance, to be published in an adjudicated newspaper, and shall post in the office of the City Clerk a certified copy of the full text of the ordinance, along with the names of those City Council members voting for and against the ordinance. The publication of a summary of the ordinance in lieu of the full text of the ordinance is authorized only where the requirements of Government Code Section 36933(c)(1) are met.

SECTION 5. EFFECTIVE DATE. This ordinance shall be effective upon the commencement of the thirty-first day following the adoption date.

SECTION 6. TRANSMISSION TO HCD. The City Clerk shall send a certified copy of this ordinance to the Department of Housing and Community Development (HCD) within sixty (60) days after adoption, as required by state law.

The foregoing ordinance was duly and properly introduced at a regular meeting of the City Council of the City of Los Altos held on _____, 2020 and was thereafter, at a regular meeting held on _____, 2020 passed and adopted by the following vote:

- AYES:
- NOES:
- ABSENT:
- ABSTAIN:

Janis C. Pepper, MAYOR

Attest:

Jon Maginot, CMC, CITY CLERK

**MINUTES OF A REGULAR MEETING OF THE PLANNING COMMISSION OF THE
CITY OF LOS ALTOS, HELD ON THURSDAY, APRIL 16, 2020 BEGINNING AT
7:00 P.M. AT LOS ALTOS CITY HALL, ONE NORTH SAN ANTONIO ROAD,
LOS ALTOS, CALIFORNIA**

Please Note: Per California Executive Order N-29-20, the Commissions will meet via teleconference only. Members of the Public may call (773) 231-9226 to participate in the meeting by phone. Members of the Public may only comment during times allotted for public comments. Public testimony will be taken at the direction of the Commission Chair and members of the public may only comment during times allotted for public comments. Those wishing to comment on an agenda item are asked to text their name and which item they wish to speak on to 650-947-2633 to better organize the public comment period. An opportunity will be provided to those who do not text to speak on each item. Members of the public are also encouraged to submit written testimony prior to the meeting at PlanningCommission@losaltosca.gov or Planning@losaltosca.gov. Emails received prior to the meeting will be included in the public record.

ESTABLISH QUORUM

PRESENT: Chair Ahi, Commissioners Bressack, Lee, Marek and Meadows
ABSENT: Commissioner Samek and Vice-Chair Bodner
STAFF: Community Development Director Biggs, Planning Services Manager Persicone and City Attorney Houston

PUBLIC COMMENT ON ITEMS NOT ON THE AGENDA

None.

CONSENT CALENDAR

1. Planning Commission Minutes

Approve minutes of the regular meeting of March 5, 2020.

Action: Upon motion by Commissioner Bressack, seconded by Commissioner Meadows, the Commission approved the minutes from the March 5, 2020 Regular Meeting as written.

The motion was approved (5-0) by the following vote:

AYES: Ahi, Bressack, Lee, Marek and Meadows

NOES: None

ABSENT: Samek and Bodner

PUBLIC HEARING

2. Zoning Text Amendment ZTA 20-0001 (Accessory Dwelling Unit Ordinance)

Zoning Text Amendments (ZTA 20-0001) to Chapter 14.14 (Accessory Dwelling Unit Ordinance) of the Los Altos Municipal Code pursuant to recent modifications to state law.

Project Manager: Guido F. Persicone, Planning Services Manager

Planning Services Manager Persicone presented the staff report recommending that the Planning Commission recommend adoption of the proposed ordinance to the City Council.

City Attorney Houston provided information regarding the 12-foot setback regarding corner lots and the needed to check with the State on whether this was compliant with recent ADU legislation.

Commissioner Meadows asked if a JADU could have separate ownership, why there were an 800 square-foot and an 850 square-foot thresholds and clarification as to what the distinctions between them are, and why are there different limits on the square footage for 1 bedroom/2 bedroom units.

Commissioner Lee asked if there was a way to better demonstrate the square footage limitations of the various types of ADU's in the form of some chart.

Chair Ahi asked if the state legislation allowed for a daylight plane or if it is prohibited. He agreed that a chart demonstrating the square footages would be good and streamline the review and approval process.

City Attorney Houston responded by stating that a daylight plane provision could be included so long as it did not preclude the construction of an ADU.

Public Comment

Resident Dan Nordin asked about section 14.14.080 and if the public utility easements can be considered in the daylight plane and if an easement affected where the daylight plane should be measured.

Resident Gary Hedden stated concern with the daylight plane requirements stating they were too restrictive and would make ADU's approved in the past non-compliant.

Resident Greg Popovich stated his support for ADU's, but expressed concern with a daylight plane standard that negates ADU's, noted the proposed daylight plane sketch does not allow for adequate design, requires use of a slab on grade foundations but not a raised footing foundation.

Resident Lou Tinder stated his interest in building an ADU and concern over the daylight plane.

Commission discussion was arranged into three topics:

- Square footage:
- Daylight plane:
- Other sections of the ADU code.

Commission Discussion on Square Footage:

Commissioner Bressack:

- Noted one big issue is that 800 square feet is mentioned three times in the state law and 1,200 square feet is mentioned only one time, why and can the City's code be simplified;
- Stated the second issue is with the proposed plane, asked "what is the goal or what are we trying to achieve; and
- Noted she likes the idea of introducing a table style into the ordinance to indicate square footage thresholds

Commissioner Meadows

- Stated that she can support the 800 square foot threshold and the 1,200 square foot ADU limits, but felt the topic deserved some additional consideration and discussion as a limit of 850 square feet was imbedded in the code.

Commissioner Marek:

- Supported the Comments of Commissioners Bressack and Meadows and added that an appropriate threshold should be arrived at 800 square feet or 850 square feet

Commissioner Lee

- Commented that the square footage discussion should consider the relationship between the size of a site and buildings that occupy the site – they are tied together ;
- He noted that 800 or 850 square feet is not a big material difference; and Stated he is comfortable with 800 square feet as well as 1,200 square feet.

Chair Ahi:

- Stated that using an 800 square foot limit makes more sense.

Commission Discussion on daylight plane:

Commissioner Bressack:

- Stated she can support the Palo Alto example for the daylight plane; and
- Noted artificial limits equate to a squashed design.
- Asked aloud if there should be a graduated scale for the daylight plane.

Commissioner Meadows

- Agreed with the Palo Alto example preliminarily and asked about other incentives that could get better results.

Commissioner Lee

- Noted the proposed daylight plane diagram does not result in favorable space inside the dwelling unit;
- Said he champions additional height because it helps support better designs;
- Suggested heights of Seven to eight feet are a plus; and
- Added a slope 1 to 1 is not in keeping with the ranch style homes in Los Altos and incentives builders and homeowners to attempt an aggressive roof design .

Public Comment Insert:

Chris Kolstad and Walter Chapman proposed an alternative ADU type that allows a JADU to be treated in a similar manner to an ADU.

City Attorney Houston stated that a JADU must be created from existing space within a structure and square footage cannot be added except for 150 square feet to allow for egress.

Chair Ahi:

- Suggested with regards to the daylight plane, an eight-foot h with a 1 to 1 slope makes a lot of sense. Even a A seven-foot height with a 1 to 1 slope would be good..

In response to comments about offering a potential financial incentive to achieve desirable site design, City Attorney Houston carefully explained that financial incentives by a City, including reducing or waiving permit fees, could require compliance with prevailing wage laws.

Commissioner Marek:

- Agreed with Chair Ahi's comments; and
- Noted a conversion requirement is based on 50 percent and can't be less than 800 square feet.

Commission Discussion on other amendments:

Commissioner Bressack:

- Stated she is okay with the language of subsection 14.14.040 (b);
- Need to evaluate subsection 14.14.040 (e) a little closer because it seems to be in reverse; and
- Concluded that subsection 14.14.040 (m) should read as follows:

(m) If the applicant requests a delay in processing, the 60-day time period shall be suspended for the period of the delay.

Commissioner Meadows

- Had questions about subsection 14.14.050 2(i).; and
- Raised a question regarding how basements should be excluded or included in the area of ADU's, whether they be detached or attached. She noted the current regulations treat the inclusion of the basement square footage differently.

Commissioner Lee

- Recommended evaluating and tweaking the daylight plane to get the affect the Commission wants; and
- Requested that sketches of the various daylight plane scenarios be provided so that different affects could be evaluated.

Chair Ahi:

- Recommended bringing back a revised ADU ordinance that includes a chart reflecting the size standards for the various types of ADU's.
- Look into other incentives and language regarding over-the-counter process approval; and
- Asked for ways to streamline the approval process be evaluated further.

City Attorney Houston explained the difference and standards for the 1,200, 850, and 800 square-ADU's.

Commissioner Bressack noted as a points to ponder:

- If you have a daylight plane, people will fill it up; and
- For parking spaces, covered or uncovered, one additional parking space should be required.

Action: Upon motion by Commissioner Bressack, seconded by Commissioner Meadows, the Commission continued the Zoning Text Amendment and ADU Ordinance to the May 7, 2020 Planning Commission meeting.

The motion was approved (5-0) by the following vote:

AYES: Ahi, Bressack, Lee, Marek and Meadows

NOES: None

ABSENT: Samek and Bodner

COMMISSIONERS' REPORTS AND COMMENTS

Commissioner Bressack reported on the April 14, 2020 City Council meeting.

POTENTIAL FUTURE AGENDA ITEMS

Planning Services Manager Persicone provided an overview of upcoming projects on the Commission's meeting agendas.

ADJOURNMENT

Chair Ahi adjourned the meeting at 9:45 P.M.

Jon Biggs
Community Development Director

DRAFT

**MINUTES OF A REGULAR MEETING OF THE PLANNING COMMISSION OF THE
CITY OF LOS ALTOS, HELD ON THURSDAY, MAY 7, 2020 BEGINNING AT
7:00 P.M. AT LOS ALTOS CITY HALL, ONE NORTH SAN ANTONIO ROAD,
LOS ALTOS, CALIFORNIA**

Please Note: Per California Executive Order N-29-20, the Commissions will meet via teleconference only. Members of the Public may call (773) 231-9226 to participate in the conference call (Meeting ID: 148 902 2429 Members of the Public may only comment during times allotted for public comments. Public testimony will be taken at the direction of the Commission Chair and members of the public may only comment during times allotted for public comments. Those wishing to comment on an agenda item are asked to text their name and which item they wish to speak on to 650-947-2633 to better organize the public comment period. An opportunity will be provided to those who do not text to speak on each item. Members of the public are also encouraged to submit written testimony prior to the meeting at PlanningCommission@losaltosca.gov or Planning@losaltosca.gov. Emails received prior to the meeting will be included in the public record.

ESTABLISH QUORUM

PRESENT: Chair Ahi, Vice-Chair Bodner, Commissioners Bressack, Lee, Marek and Meadows
ABSENT: Commissioner Samek
STAFF: Community Development Director Biggs, Planning Services Manager Persicone and City Attorney Houston

PUBLIC COMMENT ON ITEMS NOT ON THE AGENDA

None.

CONSENT CALENDAR

1. Planning Commission Minutes

Approve minutes of the regular meeting of April 16, 2020.

Action: Upon motion by Commissioner Bressack, seconded by Commissioner Meadows, to approve the minutes from the April 16, 2020 Regular Meeting with the changes mentioned by both. At the direction of Community Development Director Biggs, Commissioner Bressack withdrew her motion.

Action: Upon motion by Commissioner Bressack, seconded by Commissioner Meadows, the Commission continued the minutes from the April 16, 2020 Regular Meeting to allow edits and changes.

The motion was approved (6-0) by the following vote:

AYES: Ahi, Bodner, Bressack, Lee, Marek and Meadows

NOES: None

ABSENT: Samek

PUBLIC HEARING

2. Zoning Text Amendment ZTA 20-0001 (Accessory Dwelling Unit Ordinance)

Zoning Text Amendments (ZTA 20-0001) to Chapter 14.14 (Accessory Dwelling Unit Ordinance) of the Los Altos Municipal Code pursuant to recent modifications to state law.

This item was continued from the April 16, 2020 PC meeting. *Project Manager: Guido F. Persicone, Planning Services Manager*

Planning Services Manager Persicone gave an overview of edits to the ordinance made since the last Planning Commission meeting.

Public Comment

Resident and local architect Walter Chapman brought up an alternative JADU proposal to allow for additions greater than 150 square feet for a JADU.

Questions of staff:

Commissioner Bressack to City Attorney Houston:

- Can we recommend being more proactive and not just complying with the state's law, but do a code amendment that is more lenient and encourages ADUs? Also, can the City propose a new category that the state has not looked at yet? Are we allowed to go further as long as we are compliant?

Answer: The City can always do more to allow ADU's than required by the State, just not less. The City can allow for the expansion of the dwelling unit to allow for JADUs.

- Can the fee schedule be amended to provide a different (lesser) fee for a project with greater side yard setbacks – in an effort to encourage this?

Answer: The issue with prevailing wage is the concern with public money being used for a private project. While there is an ADU permit fee, we would have to amend our fee schedule to change it.

Commissioner Meadows to City Attorney Houston:

- Asked if everyone is entitled to a lesser setback - how is it an incentive to be a good neighbor and provide a greater setback?

Answer: The City is incentivizing ADUs generally, not just good neighbor behavior. So, it would be across the board and noted a concern with trying to incentivize some ADUs, but not all.

Vice-Chair Bodner to staff:

- There sought confirmation that there were 24 ADU applications approved in 2019, but, wondered how many ADU applications were submitted this year, before the Covid-19 quarantine?

Answer: We will probably receive more ADU applications than the 24 approved last year, as this year we have been telling people to hold off until the City creates our new regulations.

- What percentage involve JADUs and the larger ADUs?

Answer: We have seen a handful of JADUs, but the bulk have been the larger detached ADUs. A lot of them are new and under the 750 square feet.

- What level of oversight will the City have on who can develop an ADUs?

Answer: The State took away the City's ability to require the property owner occupancy deed restriction, but kept the short-term rentals prohibition in the state law.

Chair Ahi to staff:

- Asked why the school impacts fees do not go up to 800 square feet?

Answer: It is the way the state law was written so that a 750 square-foot or less ADU would not trigger school impact fees.

- If the ADU is 850 square feet or below, what type of review would it trigger?

Answer: An over-the-counter administrative review.

Commissioner Lee to staff:

- Asked for clarification on the 800 square-foot ADU vs. 850 square-foot in the chart on the fourth slide?

Answer: The State says you get a minimum of 800 square feet for an ADU regardless of the 50 percent square footage rule of the main house.

Commissioner Bressack stated a more comprehensive chart of ADU's would clarify what Commissioner Lee is asking.

Chair Ahi and Commissioner Meadows agreed with Bressack's chart suggestions. Commissioner Meadows further mentioned that a basement ADU is not limited to 1,200 square feet because zoning language is exclusive of this square footage.

Public Comment:

Walter Chapman stated that if more ADUs were integrated into the primary structure, then you will end up with less detached ADUs in the rear yard. He encouraged building integrated ADUs either partially or completely into an existing house and then expand the primary residence to its allowable square footage, what you will get is a series of larger homes and open yards. He then asked if the Commission could consider an additional option to the state if we allowed them to be integrated but clearly separated within the structure from the primary residence.

Resident Greg Popovich said an ADU with an 8-foot plate and a 6/12 pitch for the daylight plane works for the majority of the units while still meeting our goal of not having 16-foot tall units on a property that are four feet away.

Al said the daylight plane strikes a good balance. He stated that integrating ADUs into the main structure might not be in the spirit of things and serve affordable housing requirements and mentioned an 8-foot plate and a 6/12 pitch for the daylight plane was a good compromise.

Resident Chris Kolstad stated that he is not for larger homes in Los Altos, but needs a larger home and in his case, it is for an additional family. He supports Walter's concept and does not like that the state does not allow for a remodel to an existing house to build an ADU.

Commission Discussion on Square Footage:

Commissioner Meadows

- Does not know if it is correct to say that we do not allow integrated ADUs as they are allowed as a JADU and a regular ADU;
- With regards to the table, it was a great first step and the Commission has made comments around how to add some clarity to it;
- Went over various types of ADUs and categories starting with the 751 square-foot or more ADU school impact fees can be charged but must be proportionate to the size of the main house;
- Next was the category of an 800 square-foot ADU that shall not be more than 50 percent of the floor area, but noted the different rules in some of them;
- Asked if the basement area counts towards the ADU square footage and does it count towards the 50 percent rule of the main house; and
- Talked about the integration of a JADU as proposed by Walter Chapman and asked why it could not be done.

Commissioner Bressack explained Walter Chapman's suggestion for JADU integration and noted if you are going to use up some of your existing house square footage for a JADU you should get that back to use elsewhere. An advantage of this would be if the ADU is part of the main building and within the main building envelope, which is subject to our setbacks; thus, allowing greater control over the unit.

Commissioner Meadows said that this might be the incentive we have been looking for and the reason that they are precluded is because they are already at their allowed floor area ratio on the lot; aside of course from the other ADU rules.

Commissioner Bressack:

- Is in support of the concept of the integrated ADU as long as there is an 800 square-foot ADU limit.; and
- Asked if it is allowable to have an attached ADU and a JADU in the same property, to which Planning Services Manager Persicone answered "No."
- She reiterated that the first thing on the chart should be that 850 square feet is the largest allowed studio/one-bedroom unit and 1,200 square feet is the largest allowed two-bedroom unit so we start at a place where folks will understand the various restrictions.

Vice-Chair Bodner:

- In support of the recommended changes that Commissioner Bressack suggested to the categories;
- Making it clear that you do not have to build the largest ADU possible; but should scale it to be smaller, as it would better integrate into the neighborhood.;
- In support of the concept of integrated ADUs and Mr. Chapman's request; and
- Supports waiving fees because the intention of these rules is to encourage ADUs;
- With respect to the integrated ADUs, she is a little skeptical that they accomplish the intended purpose of actually providing more housing. It feels as though it is making some houses bigger; and
- Agrees that we would have greater design control with these integrated ADUs and they really become less obvious within the neighborhood.

Commissioner Marek:

- Asked about a change to subsection M that changed "tolled" to "suspended", in which Commissioner Bressack explained that she suggested the change because she did not think the public would know what "tolled" meant;
- The proposed changes to the chart are good and helpful;
- Admits he is somewhat skeptical about this entire approach as a way to truly address the housing crisis; and
- On a much larger level, are all these changes addressing the housing crisis? Do we go forward as if everything will remain the same or is there any thought given to what effect might the current crisis have on the pre-existing housing crisis?

Commissioner Lee

- At the end of the day we are talking about a range of square footages from the minimum to the maximum; and
- Wondered how do we make the square footage limitations crystal clear? Why not try to make the chart as useful as possible?

- You could even add another column for square footage pertaining to attached ADUs vs. detached ADUs;
- He does not have any objections to an integrated ADU; however, he is a bit torn because the massing of the existing house could change significantly with the addition of an ADU;
- Noted it may be better to have an ADU in the rear yard setback so it will have less impact from a street perspective; and
- Seems fair to regain some square footage for an area of a main house converted to an ADU.

Chair Ahi:

- Agrees with comments;
- The table needs to be a little bit clearer;
- Likes Commissioner Bressack's suggestion of breaking down the 850 square-foot and 1,200 square-foot ADUs by itself and then having the other numbers as separate as to what the state is allowing and what our requirements are;
- Not opposed to the concept of integrated units, but there needs to be some type of cap so that people will not take advantage of the provision; and
- The concept does make sense that if you're taking away some of the square footage of the main house, you should be able to reclaim some of it somewhere else.

Commissioner Meadows

- Asked if all specifications for an ADU could be put into a table; and
- Noted basement square footage inclusion and exclusions need to be addressed and are missing from the table.

Commissioner Bressack:

- Clarify if references to ADUs are for attached, detached, or both when we are talking about the regulations; and
- Reiterated that since 800 square feet is the lowest mandatory threshold for what we must grant, it is a good number to use when phrasing the integrated hybrid model ADU because then people cannot take advantage of the provision in a bad way, but use it to their benefit; and
- 800 square feet feels like a good threshold because it is the state's minimum mandate.

Commission Discussion on daylight plane:

Commissioner Bressack:

- Before the City got into this revision, the daylight plane law for a detached accessory building had a low pitch, then when you got 10 feet away from the property line it went to the maximum of 12 feet. What that meant was if you wanted to have a design that was not compact, you pulled the structure back 10 feet because that allowed you the greatest leeway;
- Suggested that whatever we do for the slope, the way to make it more enticing is to pick a number like 10 feet which could either be the rear or side or both and say at that point you can go to 16 feet in height;
- Because from 10 feet away it would be unusual for someone to do a 16-foot high cube, we are still more likely to get a rising pitch, but it still allows for a cross gable;

Commissioner Lee

- Asked what are we trying to achieve here with the diagrams as they seem to be missing key information;

- Are we trying to encourage homeowners to move their structure away from the property line in order to create a more favorable total distancing between the neighboring structures?
- If that is the goal, then the diagrams need to talk about that a little more directly;
- The incentive is that if you pull back a little bit further, you can build higher or create a different style of architecture; and
- That is the story that these diagrams should tell a homeowner.

Vice-Chair Bodner:

- Agrees with both Commissioner Bressack and Lee's comments in terms of first focusing on what are we trying to achieve and then making sure we are achieving it;
- We are trying to ensure that neighbors construct ADUs that are less obstructive/intrusive to their neighbors and if we need to be consistent with what our best practices are; and
- Wondered where are we landing compared to other agencies?

Chair Ahi:

- In looking back on the different daylight planes and possibilities he felt that eight feet at an 8/12 slope is a reasonable number;
- Allows for slightly more height closer to the property line;
- If you voluntarily go below an 8/12 slope, then you could qualify for reductions in fees or other type of incentives;
- Talked about an 8/12 slope with a maximum height of 16 feet at 12 feet away, and a 6/12 slope with a maximum height of 16 feet at 16 feet away and the logistics of them on a lot.

Commissioner Bressack:

- Having two daylight planes is a tough to navigate;
- Some will not be happy with anything near a property line because it is change;
- We have more control on the integrated hybrid solution because that may not be the best aesthetic solution, but at least we can control that because if it is a two-story house or even a one-story that is unusual it has to go through design review before the Design Review Commission as a house where an ADU does not;
- Differences are relatively small between the different slope pitches;
- Look at how close a 16-foot wall could be to a property line; and

Commissioner Meadows

- Agreed with comments made and noted that the diagrams show the pitch change, but the house was exactly the same in all of those scenarios and did not help visualize what those differences would mean.

Commission Discussion on other miscellaneous amendments:

Commissioner Bressack:

- Clarified and provided some text edits on page 5 of the Draft Ordinance to Planning Services Manager Persicone;
- Make it clear in the code that you cannot have an attached ADU and a JADU;
- The total floor area for an attached ADU or detached ADU (should say both) shall not exceed 1,200 square feet, excluding the basement for the main house;
- Under the Heights section, remove the reference to the "street side yard" and just use "side yard"; and

Commissioner Meadows

- Provided some text edits to the Draft Ordinance starting on page 7;
- Noted it is important to provide the note text about HCD being okay with the daylight plane in the ordinance because the daylight plane becomes unenforceable the moment it prohibits the construction of an 850 square-foot ADU; and
- At the bottom of the page 8 in design standards, it talks about ADUs over 851 square feet and what you are really intending to say is either over 850 square feet or 851 square feet or greater; and
- On page 9, the portion that says 851 square feet or greater, has some text missing.

Commission Discussion on incentives:

Commissioner Meadows:

- Talked about the integrated ADUs where if you allowed that as an option, that could be an incentive.

Commissioner Bodner:

- Is supportive of reduced fees.

Commissioner Lee:

- The integrated option is a good incentive in its own right; and
- Not having an ADU taking up room in the side yard or rear yard is a good incentive already.

Chair Ahi:

- Agrees with Commissioner Bressack and Meadows' comments;
- Thinks the integration of an ADU could definitely be a good incentive; and
- Established a consensus on the daylight plane that it will have a 6/12 slope for 10 feet from the property line and then the ADU can go up to 16 feet in height.

Action: Upon motion by Commissioner Bressack, seconded by Commissioner Meadows, the Commission continued the Zoning Text Amendment and ADU Ordinance to the May 21, 2020 Planning Commission meeting to work on the table and make other edits noted by the Commission. The motion was approved (6-0) by the following vote:

AYES: Ahi, Bodner, Bressack, Lee, Marek and Meadows

NOES: None

ABSENT: Samek

City Attorney Houston said she would take another look at the incentives.

COMMISSIONERS' REPORTS AND COMMENTS

Commissioner Meadows reported on the April 28, 2020 City Council meeting.

POTENTIAL FUTURE AGENDA ITEMS

Community Development Director Biggs provided an overview of upcoming projects on the Commission's meeting agendas.

ADJOURNMENT

Chair Ahi adjourned the meeting at 9:27 P.M.

Jon Biggs
Community Development Director

From: [Jon Biggs](#)
To: [Shahla Aly](#); [Guido Persicone](#)
Subject: RE: Request to consider using the same FAR formula for ADU's as Los Altos uses for the main building
Date: Thursday, August 13, 2020 2:49:51 PM

Thank you for your email – we will be sure to include this as correspondence when ordinance is taken back to the City Council for consideration.

Jon

From: Shahla Aly [REDACTED]
Sent: Thursday, August 13, 2020 8:58 AM
To: Jon Biggs <jbiggs@losaltosca.gov>; Guido Persicone <gpersicone@losaltosca.gov>
Subject: Request to consider using the same FAR formula for ADU's as Los Altos uses for the main building

Hi Jon and Guido,
I live at 340 W Portola Ave. We are planning to build a 2 bedroom ADU this year, and have already retained an architect.
Our lot is a double lot at 19,657 SF and we have already built to the max of our FAR - 4,712 SF.

Here is my request - Homeowners who have large lots should be allowed to build larger units (upto 1200 SF), even if they have already maxed out their FAR.

There is already a precedent to consider lot size - given that for Los Altos for lots over 11,000 square feet, the maximum floor area is 3,850 square feet plus 10% of the remaining lot area.

Would you consider applying the same formula to ADU's---starting at 850SF, and allowing a 10% increase for the SF over 11K with a ceiling of 1200SF.?

Why impose a 850SF restriction on a home that has reached its FAR, when there is plenty of space in the backyard to put up a decent sized ADU that a family can live in ? I hope that you will consider my request for next weeks city meetings.

Thank you,

Shahla Aly

Shahla Aly

[REDACTED] | [REDACTED]